

# SCR P Safety Controller

## Instruction Manual

# Contents

<b>1</b>	<b>About This Document</b>	<b>5</b>
1.1	Important... Read This Before Proceeding!	5
1.2	Use of Warnings and Cautions	5
1.3	EU Declaration of Conformity (DoC)	5
<b>2</b>	<b>Product Description</b>	<b>7</b>
2.1	Terms Used in this Manual	7
2.2	Software	7
2.3	USB Connections	7
2.4	Ethernet Connections	7
2.5	Internal Logic	8
2.6	Password Overview	8
2.7	SCR P-PA Programming Tool	8
<b>3</b>	<b>SCR P Overview</b>	<b>9</b>
3.1	SCR P Models	9
3.2	SCR P Features and Indicators	9
3.3	SCR P Using FID 2 Safety Controllers	10
3.4	Input and Output Connections	10
3.4.1	SCR P Safety and Non-Safety Input Devices	10
3.4.2	SCR P Safety Relay Outputs	10
3.4.3	SCR P Status Outputs and Virtual Status Outputs	11
3.5	SCR P Automatic Terminal Optimization (ATO) Feature with External Terminal Blocks (ETB)	11
<b>4</b>	<b>Specifications and Requirements</b>	<b>12</b>
4.1	SCR P Specifications	12
4.2	Dimensions	15
4.3	PC Requirements	15
<b>5</b>	<b>System Installation</b>	<b>16</b>
5.1	Installing the Software	16
5.2	Installing the Safety Controller	16
5.2.1	Mounting Instructions	16
<b>6</b>	<b>Installation Considerations</b>	<b>17</b>
6.1	Appropriate Application	17
6.2	SCR P Applications	17
6.3	Safety Input Devices	18
6.3.1	Safety Circuit Integrity and ISO 13849-1 Safety Circuit Principles	19
6.3.2	Safety Input Device Properties	20
6.4	Safety Input Device Options	22
6.4.1	Safety Circuit Integrity Levels	23
6.4.2	Emergency Stop Push Buttons	23
6.4.3	Rope (Cable) Pull	24
6.4.4	Enabling Device	24
6.4.5	Protective (Safety) Stop	24
6.4.6	Interlocked Guard or Gate	25
6.4.7	Optical Sensor	25
6.4.8	Two-Hand Control	26
6.4.9	Safety Mat	28
6.4.10	Muting Sensor	31
6.4.11	Bypass Switch	32
6.4.12	Adjustable Valve Monitoring (AVM) Function	33
6.4.13	DCD Inputs	34
6.5	Non-Safety Input Devices	35
6.5.1	Manual Reset Input	36
6.6	Virtual Non-Safety Input Devices	37
6.6.1	Virtual Manual Reset and Cancel Delay (RCD) Sequence	38
6.6.2	Virtual ON/OFF and Mute Enable	41
6.7	Safety Outputs	41
6.7.1	Safety Relay Outputs	44
6.7.2	EDM and FSD Hookup	44
6.8	Status Outputs	50
6.8.1	Status Output Signal Conventions	50
6.8.2	Status Output Functionality	50
6.9	Virtual Status Outputs	51

<b>7</b>	<b>Getting Started .....</b>	<b>52</b>
7.1	Creating a Configuration .....	52
7.2	Adding Inputs and Status Outputs .....	52
7.2.1	Adding Safety and Non-Safety Inputs .....	52
7.2.2	Adding Status Outputs .....	55
7.3	Designing the Control Logic .....	56
7.4	Saving and Confirming a Configuration .....	56
7.4.1	Notes on Confirming or Writing a Configuration to a Configured SCR P .....	57
7.5	Sample Configurations .....	58
<b>8</b>	<b>Software .....</b>	<b>59</b>
8.1	Abbreviations .....	59
8.2	Software Overview .....	61
8.3	Project Settings .....	63
8.4	Equipment Tab .....	64
8.5	Functional View Tab .....	65
8.6	Logic Blocks .....	66
8.7	Function Blocks .....	68
8.8	Wiring Diagram Tab .....	87
8.9	Ladder Logic Tab .....	88
8.10	DCD Tab .....	89
8.11	Industrial Ethernet Tab .....	92
8.12	Configuration Summary Tab .....	97
8.13	Print Options .....	98
8.14	SCR P Password Manager .....	99
8.15	Viewing and Importing Controller Data .....	99
8.16	Live Mode .....	101
8.17	Simulation Mode .....	104
8.18	Reference Signals .....	108
<b>9</b>	<b>Industrial Ethernet Overview .....</b>	<b>109</b>
9.1	Configuring the Safety Controller .....	109
9.2	Industrial Ethernet Definitions .....	110
9.3	Retrieving Current Fault Information .....	111
9.4	EtherNet/IP™ .....	111
9.4.1	Assembly Objects .....	111
9.4.2	Fault Examples .....	122
9.4.3	Flags .....	123
9.4.4	Extended Flags .....	124
9.5	Modbus/TCP .....	124
9.5.1	Flags .....	134
9.5.2	Extended Flags .....	135
9.5.3	Outputs from Safety Controller (Inputs to PLC) .....	135
9.5.4	Inputs to Safety Controller (Outputs from PLC) .....	143
9.5.5	Flags .....	143
9.5.6	Extended Flags .....	144
9.6	PROFINET® .....	144
9.6.1	PROFINET and the Safety Controllers .....	144
9.6.2	General Station Description (GSD) File .....	145
9.6.3	PROFINET IO Data Model .....	145
9.6.4	Configuring the Safety Controller for a PROFINET IO Connection .....	145
9.6.5	Description of Modules .....	145
9.6.6	Configuration Instructions .....	154
9.7	Temperature, Voltage, and Distance Conversion Information .....	162
9.7.1	Supply Voltage .....	162
9.7.2	Internal Temperature .....	162
9.7.3	Actuator Distance .....	163
<b>10</b>	<b>System Checkout .....</b>	<b>165</b>
10.1	Schedule of Required Checkouts .....	165
10.2	Commissioning Checkout Procedure .....	165
10.2.1	Verifying System Operation .....	165
10.2.2	Initial Setup, Commissioning, and Periodic Checkout Procedures .....	166
<b>11</b>	<b>Status and Operating Information .....</b>	<b>172</b>
11.1	SCR P LED Status .....	172
11.2	Live Mode Information: Software .....	174
11.3	Lockout Conditions .....	174
11.4	Recovering from a Lockout .....	175
11.5	SCR P Using Automatic Terminal Optimization .....	175
11.6	SCR P Example Configuration without Automatic Terminal Optimization .....	177
11.7	SCR P Using the SCR P-FPS .....	181
11.8	Reset the Safety Controller to Factory Defaults .....	182
11.9	Factory Defaults .....	182

<b>12 Troubleshooting</b> .....	<b>184</b>
12.1 Software: Troubleshooting .....	184
12.2 Software: Error Codes .....	185
12.3 Verifying Driver Installation .....	186
12.4 Finding and Fixing Faults .....	188
12.4.1 SCR P Fault Code Table.....	188
<b>13 Components and Accessories</b> .....	<b>191</b>
13.1 Replacement Parts and Accessories.....	191
<b>14 Product Support and Maintenance</b> .....	<b>191</b>
14.1 Cleaning.....	191
14.2 Repairs and Warranty Service .....	191
14.3 Contact Us.....	191
14.4 BERNSTEIN Software Copyright Notice .....	191
<b>15 Standards and Regulations</b> .....	<b>192</b>
15.1 Applicable European and International Standards .....	192
15.2 Applicable U.S. Standards .....	193
15.3 Applicable OSHA Regulations.....	193
<b>16 Glossary</b> .....	<b>194</b>

# 1 About This Document

## 1.1 Important... Read This Before Proceeding!

It is the responsibility of the machine designer, controls engineer, machine builder, machine operator, and/or maintenance personnel or electrician to apply and maintain this device in full compliance with all applicable regulations and standards. The device can provide the required safeguarding function only if it is properly installed, properly operated, and properly maintained. This manual attempts to provide complete installation, operation, and maintenance instruction. *Reading the manual in its entirety is highly recommended.* Please direct any questions regarding the application or use of the device to BERNSTEIN.

For more information regarding international institutions and U.S. that provide safeguarding application and safeguarding device performance standards, see [Standards and Regulations](#) on p. 192.



**WARNING:**

- The user is responsible for following these instructions.
- **Failure to follow any of these responsibilities may potentially create a dangerous condition that could result in serious injury or death.**
- Carefully read, understand, and comply with all instructions for this device.
- Perform a risk assessment that includes the specific machine guarding application. Guidance on a compliant methodology can be found in ISO 12100 or ANSI B11.0.
- Determine what safeguarding devices and methods are appropriate per the results of the risk assessment and implement per all applicable local, state, and national codes and regulations. See ISO 13849-1, ANSI B11.19, and/or other appropriate standards.
- Verify that the entire safeguarding system (including input devices, control systems, and output devices) is properly configured and installed, operational, and working as intended for the application.
- Periodically re-verify, as needed, that the entire safeguarding system is working as intended for the application.

## 1.2 Use of Warnings and Cautions

The precautions and statements used throughout this document are indicated by alert symbols and must be followed for the safe use of the BERNSTEIN Safety Controller. Failure to follow all precautions and alerts may result in unsafe use or operation. The following signal words and alert symbols are defined as follows:

Signal Word	Definition	Symbol
<b>WARNING</b>	<b>Warnings</b> refer to potentially hazardous situations which, if not avoided, could result in serious injury or death.	
<b>CAUTION</b>	<b>Cautions</b> refer to potentially hazardous situations which, if not avoided, could result in minor or moderate injury.	

These statements are intended to inform the machine designer and manufacturer, the end user, and maintenance personnel, how to avoid misapplication and effectively apply the BERNSTEIN Safety Controller to meet the various safeguarding application requirements. These individuals are responsible to read and abide by these statements.

## 1.3 EU Declaration of Conformity (DoC)



**EU-Konformitätserklärung / EU Declaration of Conformity / Déclaration UE de conformité**

Diese Konformitätserklärung entspricht der europäischen Norm DIN EN ISO/IEC 17050-1: Konformitätsbewertung – Konformitätserklärung von Anbietern – Teil 1: Allgemeine Anforderungen. Die Grundlage der Kriterien sind internationale Dokumente, insbesondere ISO/IEC-Leitfaden 22, 1982, Informations on manufacturer's declaration of conformity with standards or other technical specifications. Die deutsche Sprachfassung ist die Originalkonformitätserklärung. Bei anderen Sprachen handelt es sich um die Übersetzung der Originalkonformitätserklärung.

This Declaration of Conformity is suitable to the European Standard EN ISO/IEC 17050-1: Conformity assessment – Supplier's declaration of conformity – Part 1: General requirements. The basis for the criteria has been found in international documentation, particularly in: ISO/IEC Guide 22, 1982, Informations on manufacturer's declaration of conformity with standards or other technical specifications. The original Declaration of Conformity is the German language version. Other languages are a translation of the original Declaration of Conformity.

Cette déclaration de conformité correspond au Norme Européenne EN ISO/IEC 17050-1 : Évaluation de la conformité – Déclaration de conformité du fournisseur – Partie 1 : Exigences générales. La base des directives sont des documents internationaux répondant à ISO/IEC-Guide 22, 1982, Informations on manufacturer's declaration of conformity with standards or other technical specifications. La version allemande est la langue d'origine de la déclaration de conformité. Les autres langues ne sont qu'une traduction de la déclaration de conformité en langue allemande.

Wir / We / Nous

**BERNSTEIN AG**

(Name des Anbieters) / (Supplier's name) / (Nom du fournisseur)

**Hans-Bernstein-Straße 1**

**D-32457 Porta Westfalica**

(Anschrift) / (Address) / (Adresse)

erklären in alleiniger Verantwortung, dass das (die) Produkt(e):  
declare under our sole responsibility that the product(s):  
déclarons sous notre seule responsabilité que le(s) produit(s):

**Programmierbare Sicherheitsauswertung / Programmable Safety Controller  
Typ / Type: SCR P...**

...(siehe Betriebs- und Montageanleitung / refer to Installation and Operating Instructions / voir Instructions de service et de montage)

(Bezeichnung, Typ oder Modell, Los-, Chargen- oder Serien-Nr., möglichst Herkunft und Stückzahl)  
(Name, type or model, batch or serial number, possibly sources and number of items)  
(Nom, type ou modèle, n° de lot, d'échantillon ou de série, éventuellement les sources et le nombre d'exemplaires)

mit folgenden Europäischen Richtlinien übereinstimmt (übereinstimmen):  
is (are) in conformity with the following directives:  
est (sont) conforme(s) aux directives européennes :

**Maschinenrichtlinie / Machinery-Directive 2006/42/EC  
EMV-Richtlinie / EMC-Directive 2014/30/EU  
RoHSII Richtlinie / RoHSII Directive 2011/65/EU**

Dies wird nachgewiesen durch die Einhaltung folgender Norm(en):  
This is documented by the accordance with the following standard(s):  
Notre justification est l'observation de la (des) norme(s) suivante(s):

**IEC 62061:2015; EN ISO 13849-1:2015  
IEC 61508 Parts 1-7:2010; IEC 61326-3-1:2017  
IEC 61131-2:2017**

Benannte Stelle / Notified Body / Organisme Notifié

**NB 0035  
TÜV Rheinland Industrieservice GmbH, Am Grauen Stein, 51105 Köln  
EG-Baumusterprüfbescheinigung Reg.-No.: 01/205/5782.00/20**

Name und Anschrift Bevollmächtigter Dokumentation:  
Name and address of authorized agent documentation:  
Nom et adresse de la documentation autorisée :  
**Herr Roland Mönnings D-32457 Porta Westfalica, Hans-Bernstein-Straße 1**

**i.V. Wolfgang Vogt  
Compliance Officer Product**

Porta Westfalica, 09.07.2020

(Ort und Datum der Ausstellung):  
(place and date of issue):  
(date et lieu d'établissement) :

(Name, Funktion) (Unterschrift):  
(name, function) (signature):  
(nom, fonction) (signature):

## 2 Product Description

Safety control is a critical and required part of any safety system. This is because safety controllers ensure that your safety measures 1) do not fail, or 2) if failure is inevitable, fail in a predictable safe way.

A safety controller is often an ideal safety control solution, because it provides more functionality than a safety relay, at a lower cost than a safety PLC. In addition, a smart, scalable safety controller can expand with your needs as well as enable remote monitoring of your machine safety systems.

BERNSTEIN Safety Controllers are easy-to-use, configurable, and designed to monitor multiple safety and non-safety input devices, providing safe stop and start functions for machines with hazardous motion. The Safety Controller can replace multiple safety relay modules in applications that include such safety input devices as E- stop buttons, interlocking gate switches, safety light curtains, two-hand controls, safety mats, and other safeguarding devices. The Safety Controller may also be used in place of larger and more complex safety PLCs with the use of additional input and/or output expansion modules.

The onboard interface:

- Provides access to fault diagnostics
- Allows reading and writing the configuration file from and to the SCR P-FPS drives

### 2.1 Terms Used in this Manual

---

The following terms are used in this manual.

**Safety Controller**—an abbreviated version referring to the SCR P

**SCR P**—formal name of the SCR P product line

### 2.2 Software

---

The BERNSTEIN Safety Controller Software is an application with real-time display and diagnostic tools that are used to:

- Design and edit configurations
- Test a configuration in Simulation Mode
- Write a configuration to the Safety Controller
- Read the current configuration from the Safety Controller
- Display the real-time information, such as device statuses
- Display the fault information

The Software uses icons and circuit symbols to assist in making appropriate input device and property selections. As the various device properties and I/O control relationships are established on the **Functional View** tab, the program automatically builds the corresponding wiring and ladder logic diagrams.

See [Software Overview](#) on p. 61 for details.

### 2.3 USB Connections

---

The micro USB port on the Base Controller and the SCR P is used to connect to the PC (via the USB cable) and the SCR P-FPS drive to read and write configurations created with the Software.



#### **CAUTION: Potential for Unintended Ground Return Path**

The USB interface is implemented in an industry standard way and is not isolated from the 24 V supply.

The USB cable makes it possible for the computer and safety controller to become part of an unintended ground return path for other connected equipment. A large current could damage the PC and/or the Safety Controller. To minimize this possibility, BERNSTEIN recommends that the USB cable is the only cable connected to the PC. This includes disconnecting the AC power supply to a laptop whenever possible. The USB interface is intended for downloading configurations and temporary monitoring or troubleshooting. It is not designed for continuous use.

### 2.4 Ethernet Connections

---

Ethernet connections are made using an Ethernet cable connected from the Ethernet port of the Base Safety Controller (Ethernet models only) or SCR P to a network switch or to the control or monitoring device. The Safety Controller supports either the standard or crossover-style cables. A shielded cable may be needed in high-noise environments.

## 2.5 Internal Logic

The Safety Controller's internal logic is designed so that a Safety Output can turn On only if all the controlling safety input device signals and the Safety Controller's self-check signals are in the Run state and report that there is no fault condition. The BERNSTEIN Safety Controller Software uses both Logic and Safety Function blocks for simple and more advanced applications.



Logic Blocks are based on Boolean (True or False) logic laws. The following Logic Blocks are available:

- NOT
- AND
- OR
- NAND
- NOR
- XOR
- Flip Flop (Set priority and Reset priority)

See [Logic Blocks](#) on p. 66 for more information.



Function Blocks are pre-programmed blocks with built-in logic which provide various attribute selections to serve both common and complex application needs. The following Function Blocks are available:

- Bypass Block
- Enabling Device Block
- Latch Reset Block
- Muting Block
- THC (Two-Hand Control) Block
- Delay Block

See [Function Blocks](#) on p. 68 for more information.

## 2.6 Password Overview

A password is required to confirm and write the configuration to the Safety Controller and to access the Password Manager via the Software. See and [SCR P Password Manager](#) on p. 99 for more information.

## 2.7 SCR P-PA Programming Tool

Use the SCR P-FPS drives to store a **confirmed** configuration.



**Important:** Verify that the configuration that is being imported to the Safety Controller is the correct configuration (via the Software or writing on the white label on the SCR P-FPS drive).

Click  to access the programming tool options:

- **Read**—reads the current Safety Controller configuration from the SCR P-FPS drive and loads it to the Software
- **Write**—writes a confirmed configuration from the Software to the SCR P-FPS drive
- **Lock**—locks the SCR P-FPS drive preventing any configurations from being written to it (an empty drive cannot be locked)



**Note:** You will not be able to unlock the SCR P-FPS drive after it has been locked.



### 3 SCR P Overview

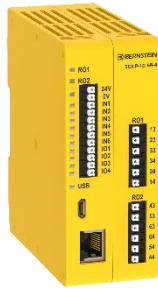

Figure 1: Safety Controller SCR P

BERNSTEIN's SCR P configurable safety relay controller is an easy-to-use and cost-effective alternative to safety relay modules. It replaces the functionality and capability of two independent safety relay modules while offering the configurability, simplicity, and advanced diagnostics capabilities offered by the rest of the BERNSTEIN Safety Controller line-up.

- Intuitive, icon-based programming with drag-and-drop PC configuration simplifies device setup and management
- Two six-amp safety relay outputs, each with three N.O. sets of contacts
- Ten inputs, including four that can be used as non-safe outputs
- Innovative daisy Chain Diagnostic (DCD)
- Automatic Terminal Optimization (ATO) can increase the inputs from 10 to up to 14
- Industrial Ethernet two-way communication
  - 256 virtual non-safe status outputs
  - 80 virtual non-safe inputs (reset, on/off, cancel off-delay, mute enable)
  - Provision of DCD diagnostic data
- SCR P-FPS external drive for fast swap and quick configuration without a PC (see [SCR P: Using the SCR P-FPS](#) on p. 181)

#### 3.1 SCR P Models

Model	Description
SCR P-10-6R-4	Configurable safety relay controller - 10 inputs (4 convertible), two 3-channel safety relay outputs, Daisy Chain Diagnostic, Industrial Ethernet

#### 3.2 SCR P Features and Indicators

Connection points are push-in spring clamp connectors.

**Wire Size:** 0.2 mm<sup>2</sup> to 2.08 mm<sup>2</sup>, 24 to 14 AWG



**Important:** Clamp terminals are designed for one wire only. If more than one wire is connected to a terminal, a wire could loosen or become completely disconnected from the terminal, causing a short.

Use a stranded wire or a wire with an accompanying ferrule. Tinned wires are not recommended.

After inserting the wire into the terminal, tug the wire to make sure it is properly retained. If the wire is not retained, consider using a different wiring solution.

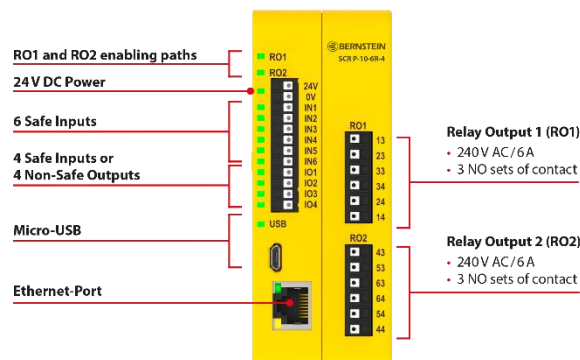

Figure 2: Features and Indicators

### 3.3 SCR P Using FID 2 Safety Controllers

Over time, BERNSTEIN adds new features to some devices. The Feature ID (FID) identifies the set of features and functions included in a particular model. Generally, an increasing FID number corresponds to an increasing feature set. A configuration using a higher numbered FID feature is not supported by a Safety Controller of a lower FID. Feature sets are forward compatible, not backwards compatible.

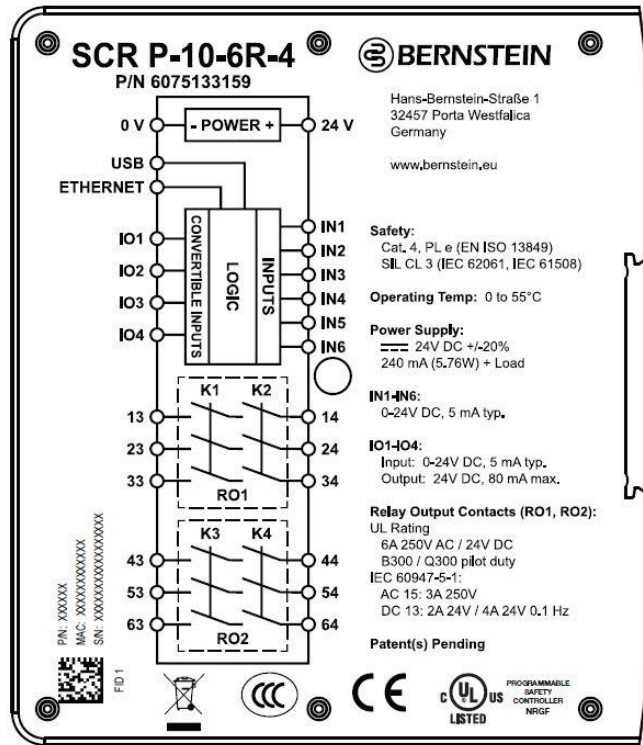

Figure 3: Example SCR P label

### 3.4 Input and Output Connections

#### 3.4.1 SCR P Safety and Non-Safety Input Devices

The SCR P has 10 input terminals that can be used to monitor either safety or non-safety devices; these devices may incorporate either solid-state or contact-based outputs.

Some of the input terminals can be configured to either source 24 V dc for monitoring contacts or to signal the status of an input or an output. The function of each input circuit depends on the type of the device connected; this function is established during the controller configuration.

#### 3.4.2 SCR P Safety Relay Outputs

The SCR P has two, three-channel, normally open (N.O.), safety relay outputs.

The Safety Outputs are designed to control Final Switching Devices (FSDs) and Machine Primary Control Elements (MPCEs) that are the last elements (in time) to control the dangerous motion. These control elements include relays, contactors, solenoid valves, motor controls, and other devices that may also incorporate force-guided (mechanically-linked) monitoring contacts, or electrical signals needed for external device monitoring (EDM).

### Functional Stops according to IEC 60204-1 and ANSI NFPA79

The Safety Controller is capable of performing two functional stop types:

- Category 0: an uncontrolled stop with the immediate removal of power from the guarded machine
- Category 1: a controlled stop with a delay before power is removed from the guarded machine

Delayed stops can be used in applications where machines need power for a braking mechanism to stop the hazardous motion.

### 3.4.3 SCR P Status Outputs and Virtual Status Outputs

Using the Software, the SCR P can be configured for up to 256 virtual status outputs to communicate information over the network. These outputs have the capability to send non-safety status signals to devices such as programmable logic controllers (PLCs) or human machine interfaces (HMIs). See [Virtual Status Outputs](#) on p. 51 for more information.

The SCR P has four convertible I/Os (labeled **IOx**) that can be used as Status Outputs to directly control indicator lights or be hard wired inputs to PLCs. These outputs communicate the same information as the virtual status outputs.



**WARNING:**

- **Status Outputs and Virtual Status Outputs are not safety outputs and can fail in either the On or the Off state.**
- If a Status Output or a Virtual Status Output is used to control a safety-critical application, a failure to danger is possible and may lead to serious injury or death.
- Never use a Status Output or Virtual Status Output to control any safety-critical applications.

The SCR P FID 2 or later can act as an interface to provide data from a chain of devices with imbedded Daisy Chain Diagnostic (DCD) data, such as BERNSTEIN SRF Safety Switches, over the network.

## 3.5 SCR P Automatic Terminal Optimization (ATO) Feature with External Terminal Blocks (ETB)

Automatic Terminal Optimization (ATO) Feature with External Terminal Blocks (ETB) is a standard feature on all SCR P models and is enabled by default.

The ATO feature can expand the 10 terminals on the SCR P-2 to work with additional inputs by optimizing terminals and using ETBs. As devices are added, deleted or edited, the Software automatically provides the optimum terminal assignment to minimize wiring and maximize terminal utilization.

ATO is a smart feature that provides all available device types and configuration options as a configuration is created. After all IN and I/O terminals are occupied and another device is added, ATO looks for devices that require +24 V test pulses from the Safety Controller. These devices are combined via an External Terminal Block (ETB) to free up an I/O terminal. Each ETB allows for up to three different devices to share a single I/O +24 V signal.

Disable ATO by editing the module properties of the SCR P in the Software, if preferred. ETBs will still be active, but you will be required to re-assign I/O terminals manually as needed to fully optimize terminal utilization.

# 4 Specifications and Requirements

## 4.1 SCR P Specifications

### Power

**Voltage:** 24 V DC  $\pm 20\%$   
(SELV/PELV)

**Current:**

- 240 mA maximum, no load (relays on)
- 530 mA maximum, full load (IO1 to IO4 used as auxiliary outputs)

### Safety Inputs (and Convertible I/O when used as inputs)

**Input On threshold:** > 15 V dc (guaranteed on), 30 V dc maximum

**Input Off threshold:** < 5 V dc and < 2 mA, -3 V dc minimum

**Input On current:** 5 mA typical at 24 V dc, 50 mA peak contact cleaning current at 24 V dc

**Input lead resistance:** 300  $\Omega$  maximum (150  $\Omega$  per lead)

**Input requirements for a 4-wire Safety Mat:** <sup>2</sup>

- Maximum capacity between plates: 0.22  $\mu\text{F}$
- Maximum capacity between bottom plate and ground: 0.22  $\mu\text{F}$
- Maximum resistance between the 2 input terminals of one plate: 20  $\Omega$

### Convertible I/O

**Sourcing current:** 80 mA maximum (overcurrent protected) **Test Pulses:** ~1 ms every 25 to 75 ms

### Daisy Chain Diagnostic

Two diagnostic series connectable (IN3+4 and IN5+6)  
Up to 32 safety devices connected per series

### Automatic Terminal Optimization Feature

Up to three devices connected with user-provided terminal blocks

### Network Interface

Ethernet 10/100 Base-T/TX, RJ45 modular connector

Selectable auto negotiate or manual rate and duplex

Auto MDI/MDIX (auto cross)

**Protocols:** EtherNet/IP (with PCCC), Modbus/TCP, and PROFINET

**Data:** 256 virtual Status Outputs; fault diagnostic codes and messages; access to fault log

---

<sup>2</sup> If the safety mats share a convertible I/O, this is the total capacitance of all shared safety mats.

**Response and Recovery Times**

**Input to Output Response Time (Input Stop to Output Off):** see the Configuration Summary in the Software, as it can vary  
**Input Recovery Time (Stop to Run):** Turn On Delay (if set) plus 250 ms typical (400 ms maximum)  
**Virtual Input (Mute Enable and On/Off) Timing:** RPI + 200 ms typical  
**Virtual Input (Manual Reset and Cancel Delay) Timing:** see [Virtual Non- Safety Input Devices](#) on p. 37 for details

**Off Delay Tolerance**

The maximum is the response time given in the configuration summary plus 0.02%  
 The minimum is the configured off delay time minus 0.02% (assuming no power loss or faults)

**On Delay Tolerance**

The maximum is the configured on delay plus 0.02% plus 250ms typical (400 ms maximum)  
 The minimum is the configured on delay minus 0.02%

**Safety Outputs**

3 NO sets of contacts for each output channel (RO1 and RO2).  
 Each normally open output is a series connection of contacts from two forced-guided (mechanically linked) relays. RO1 consists of relays K1 and K2. RO2 consists of relays K3 and K4.

**Contacts**

AgNi + 0.2 µm gold

**Overvoltage Category**

Output relay contact voltage of 1 V to 150 V ac/dc: Category III Output relay contact voltage of 151 V to 250 V ac/dc: Category II (Category III, if appropriate overvoltage reduction is provided, as described in this document.)

**Individual Contact Current Rating**

Refer to the Temperature Derating graph when more than one contact output is used.

	Minimum	Maximum
Voltage	10 V ac/dc	250 V ac / 24 V dc
Current	10 mA ac/dc	6 A
Power	100 mW (100 mVA)	200 W (2000 VA)

**Switching Capacity (IEC 60947-5-1)**

AC 15	NO: 250 V ac, 3 A
DC 13	NO: 24 V dc, 2 A
DC 13 at 0.1 Hz	NO: 24 V dc, 4 A

**Operating Conditions**

**Temperature:** 0 °C to +55 °C (+32 °F to +131 °F) (see Temperature Derating graph)  
**Storage Temperature:** -30 °C to +65 °C (-22 °F to +149 °F)  
**Humidity:** 90% at +50 °C maximum relative humidity (non-condensing) **Operating Altitude:** 2000 m maximum (6562 ft maximum)

**Environmental Rating**

IP20 due to IEC (NEMA 1), for use inside IP54 due to IEC (NEMA 3) or better enclosure

**Mechanical Stress**

**Shock:** 15 g for 11 ms, half sine, 18 shocks total (per IEC 61131-2)  
**Vibration:** 3.5 mm occasional / 1.75 mm continuous at 5 Hz to 9 Hz, 1.0 g occasional and 0.5 g continuous at 9 Hz to 150 Hz: all at 10 sweep cycles per axis (per IEC 61131-2)

**Mechanical Life**

20,000,000 cycles

**Electrical Life**

50,000 cycles at full resistive load

**UL Pilot Duty**

B300 Q300

**B10d Values**

Voltage	Current	B10d
230 V ac	2 A	350,000
230 V ac	1 A	1,000,000
24 V dc	≤ 4 A	10,000,000

**Push-in Spring Clamp Terminals**



**Important:** Clamp terminals are designed for one wire only. If more than one wire is connected to a terminal, a wire could loosen or become completely disconnected from the terminal, causing a short.

Use a stranded wire or a wire with an accompanying ferrule. Tinned wires are not recommended.

After inserting the wire into the terminal, tug the wire to make sure it is properly retained. If the wire is not retained, consider using a different wiring solution.

**Wire Size:** 0.2 mm<sup>2</sup> to 2.08 mm<sup>2</sup>, 24 to 14 AWG

**EMC**

Meets or exceeds all EMC requirements for immunity per IEC 61326-3-1:2012 and emissions per CISPR 11:2004 for Group 1, Class A equipment



**Note:** Transient suppression is recommended when switching inductive loads. Install suppressors across load. Never install suppressors across output contacts (see Warning).

**Safety**

Category 4, PL e (EN ISO 13849)  
SIL CL 3 (IEC 62061, IEC 61508)

**Safety Ratings**

PFH [1/h]: 5.01 × 10  
Proof Test Interval: 20 years

**Product Performance Standards**

See [Standards and Regulations](#) on p. 192 for a list of industry applicable U.S. and international standards

**Certifications**



**Required Overcurrent Protection**



**WARNING:** Electrical connections must be made by qualified personnel in accordance with local and national electrical codes and regulations.

Overcurrent protection is required to be provided by end product application per the supplied table.  
Overcurrent protection may be provided with external fusing or via Current Limiting, Class 2 Power Supply.  
Supply wiring leads < 0,20mm<sup>2</sup> (24 AWG) shall not be spliced.  
For additional product support, go to [www.bernstein.eu](http://www.bernstein.eu).

Supply Wiring (mm <sup>2</sup> /AWG)	Required Overcurrent Protection (A)
0,50 / 20	5.0
0,32 / 22	3.0
0,20 / 24	2.0
0,13 / 26	1.0
0,08 / 28	0.8
0,05 / 30	0.5

**SCR P Temperature Derating**

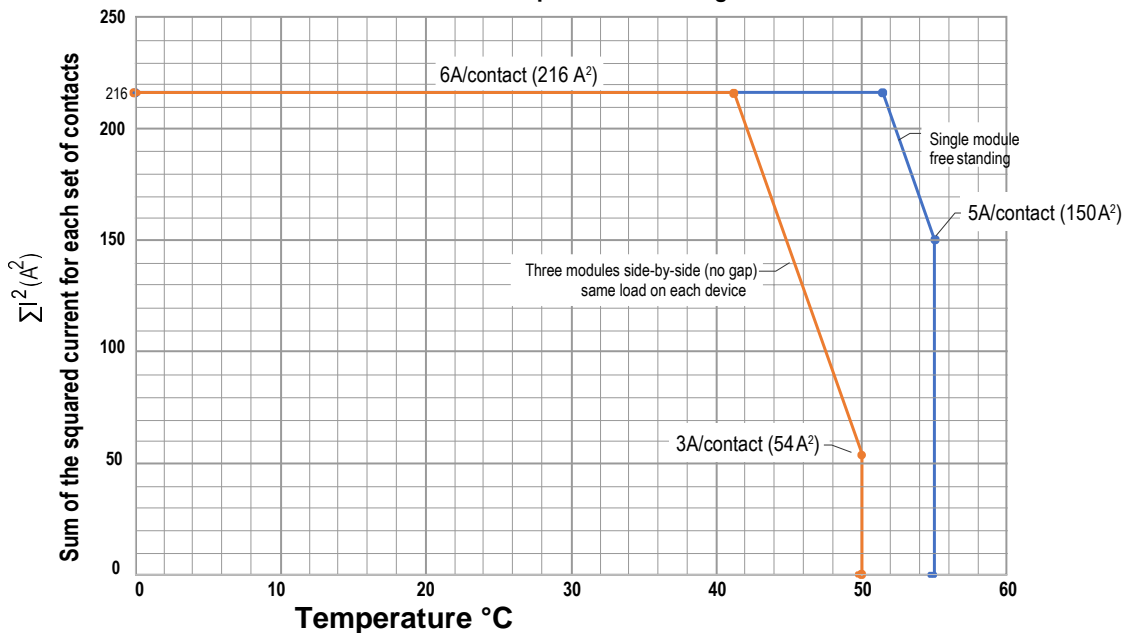

**Example Temperature Derating Calculations**

Single Unit, Free Standing	Three Modules
$\sum I^2 = I_1^2 + I_2^2 + I_3^2 + I_4^2 + I_5^2 + I_6^2$	$\sum I^2 = I_1^2 + I_2^2 + I_3^2 + I_4^2 + I_5^2 + I_6^2$ (all six modules)
$I_1 = 4 \text{ A}$ (normally open output RO1 channel 1)	$I_1 = 4 \text{ A}$
$I_2 = 4 \text{ A}$ (normally open output RO1 channel 2)	$I_2 = 4 \text{ A}$
$I_3 = 4 \text{ A}$ (normally open output RO1 channel 3)	$I_3 = 4 \text{ A}$
$I_4 = 4 \text{ A}$ (normally open output RO2 channel 4)	$I_4 = 4 \text{ A}$

### Example Temperature Derating Calculations

Single Unit, Free Standing	Three Modules
$I_5 = 4 \text{ A}$ (normally open output RO2 channel 5)	$I_5 = 4 \text{ A}$
$I_6 = 4 \text{ A}$ (normally open output RO2 channel 6)	$I_6 = 4 \text{ A}$
$\sum I^2 = 4^2 + 4^2 + 4^2 + 4^2 + 4^2 + 4^2 = 96 \text{ A}^2$	$\sum I^2 = 4^2 + 4^2 + 4^2 + 4^2 + 4^2 + 4^2 = 96 \text{ A}^2$
$T_{\max} = 55 \text{ }^\circ\text{C}$	$T_{\max} = 46 \text{ }^\circ\text{C}$

## 4.2 Dimensions

All measurements are listed in millimeters, unless noted otherwise.

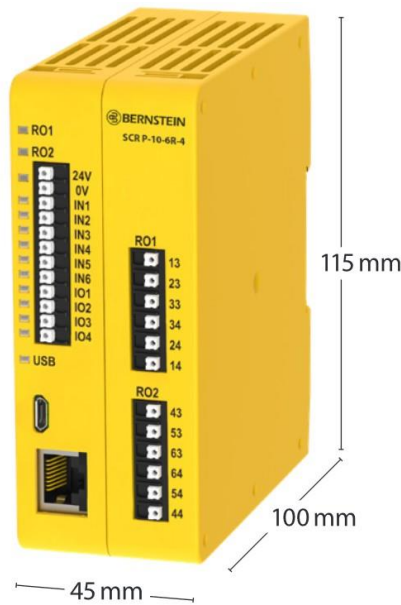

Figure 4: SCR P Dimensions

## 4.3 PC Requirements



**Important:** Administrative rights are required to install the Safety Controller drivers (needed for communication with the controller).

<b>Operating system:</b>	Microsoft Windows 7, Windows 8 (except Windows RT), or Windows 10 <sup>3</sup>
<b>System type:</b>	32-bit, 64-bit
<b>Hard drive space:</b>	80 MB (plus up to 280 MB for Microsoft .NET 4.0, if not already installed)
<b>Memory (RAM):</b>	512 MB minimum, 1 GB+ recommended
<b>Processor:</b>	1 GHz minimum, 2 GHz+ recommended
<b>Screen resolution:</b>	1024 × 768 full color minimum, 1650 × 1050 full color recommended
<b>Third-party software:</b>	Microsoft .NET 4.0 (included with installer), PDF Viewer (such as Adobe Acrobat) <b>USB port:</b> USB 2.0 (not required to build configurations)

<sup>3</sup> Microsoft and Windows are registered trademarks of Microsoft Corporation in the United States and/or other countries.

# 5 System Installation

## 5.1 Installing the Software

---



**Important:** Administrative rights are required to install the Safety Controller drivers (needed for communication with the controller).

1. Download the latest version of the software from [www.bernstein.eu/downloads](http://www.bernstein.eu/downloads)
2. Navigate to and open the downloaded file.
3. Click **Next** to begin the installation process.
4. Confirm the software destination and availability for users and click **Next**.
5. Click **Next** to install the software.
6. Depending on your system settings, a popup window may appear prompting to allow BERNSTEIN Safety Controller to make changes to your computer. Click **Yes**.
7. Click **Close** to exit the installer.

Open **BERNSTEIN Safety Controller** from the **Desktop** or the **Start Menu**.

## 5.2 Installing the Safety Controller

---

Do not exceed the operating specifications for reliable operation. The enclosure must provide adequate heat dissipation so that the air closely surrounding the Safety Controller does not exceed its maximum operating temperature (see [Specifications and Requirements](#) on p. 12).



**Important:** Mount the Safety Controller in a location that is free from large shocks and high-amplitude vibration.



**CAUTION:** Electrostatic Discharge (ESD) can cause damage to electronic equipment. To prevent this, follow the proper ESD handling practices such as wearing an approved wrist strap or other grounding products, or touching a grounded object before handling the modules. See ANSI/ESD S20.20 for further information about managing ESD.

### 5.2.1 Mounting Instructions

The Safety Controller mounts to a standard 35 mm DIN-rail track. It must be installed inside an enclosure rated IP54 due to IEC (NEMA 3) or better. It should be mounted to a vertical surface with the vent openings at the bottom and the top to allow for natural convection cooling.

Follow the mounting instructions to avoid damage to the Safety Controller.

To **mount** the SCR P Safety Controller:

1. Tilt the top of the module slightly backward and place it on the DIN rail.
2. Straighten the module against the rail.
3. Lower the module onto the rail.

To **remove** SCR P Safety Controller:

1. Push up on the bottom of the module.
2. Tilt the top of the module slightly forward.
3. Lower the module after the top rigid clip is clear of the DIN rail.



**Note:** To remove an expansion module, pull apart other modules on each side of the desired module to free bus connectors.



## 6 Installation Considerations

### 6.1 Appropriate Application

The correct application of the Safety Controller depends on the type of machine and the safeguards that are to be interfaced with the Safety Controller. **If there is any concern about whether or not your machinery is compatible with this Safety Controller, contact BERNSTEIN AG.**



**WARNING: Not a Stand-Alone Safeguarding Device**

This BERNSTEIN device is considered complementary equipment that is used to augment safeguarding that limits or eliminates an individual's exposure to a hazard without action by the individual or others. **Failure to properly safeguard hazards according to a risk assessment, local regulations, and relevant standards may lead to serious injury or death.**



**WARNING: User Is Responsible for Safe Application of this device**

The application examples described in this document depict generalized guarding situations. Every guarding application has a unique set of requirements.

Make sure that all safety requirements are met and that all installation instructions are followed. Direct any questions regarding safeguarding to a BERNSTEIN application engineer at the number or addresses listed in this document.



**WARNING: Read this Section Carefully Before Installing the System**

The BERNSTEIN Safety Controller is a control device that is intended to be used in conjunction with a machine safeguarding device. Its ability to perform this function depends upon the appropriateness of the application and upon the Safety Controller's proper mechanical and electrical installation and interfacing to the machine to be guarded.

If all mounting, installation, interfacing, and checkout procedures are not followed properly, the Bernstein Safety Controller cannot provide the protection for which it was designed. The user is responsible for satisfying all local, state, and national laws, rules, codes, or regulations relating to the installation and use of this control system in any particular application. Make sure that all safety requirements have been met and that all technical installation and maintenance instructions contained in this document are followed.

### 6.2 SCR P Applications

The SCR P Safety Controller is ideal for any small to medium size machine that would typically use two independent safety relay modules.

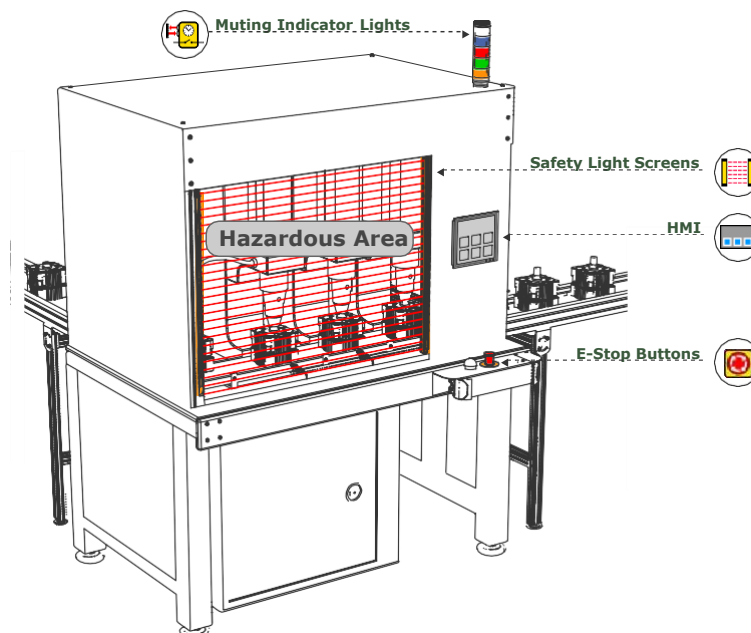

Figure 5: SCR P Sample Application 1

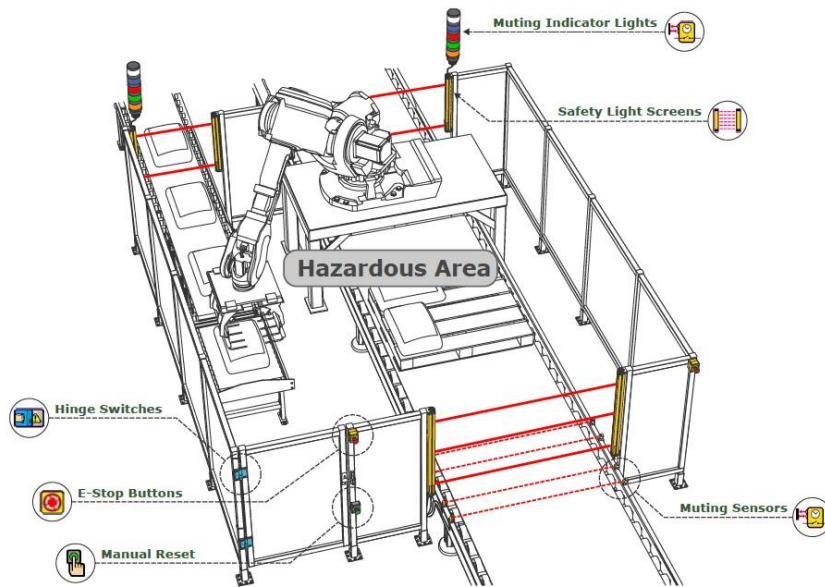

Figure 6: SCR P Sample Application 2

## 6.3 Safety Input Devices

The Safety Controller monitors the state of the safety input devices that are connected to it. In general, when all of the input devices that have been configured to control a particular Safety Output are in the Run state, the Safety Output turns on or remains On. When one or more of the safety input devices change from Run state to Stop state, the Safety Output turns Off. A few special safety input device functions can, under predefined circumstances, temporarily suspend the safety input stop signal to keep the Safety Output On, for example, muting or bypassing.

The Safety Controller can detect input faults with certain input circuits that would otherwise result in a loss of the control of the safety function. When such faults are detected, the Safety Controller turns the associated outputs Off until the faults are cleared. The function blocks used in the configuration impact the safety outputs. It is necessary to carefully review the configuration if the input device faults occur.

Methods to eliminate or minimize the possibility of these faults include, but are not limited to:

- Physically separating the interconnecting control wires from each other and from secondary sources of power
- Routing interconnecting control wires in separate conduit, runs, or channels
- Locating all control elements (Safety Controller, interface modules, FSDs, and MPCEs) within one control panel, adjacent to each other, and directly connected with short wires
- Properly installing multi-conductor cabling and multiple wires through strain-relief fittings. Over-tightening of a strain-relief can cause short circuits at that point
- Using positive-opening or direct-opening components, as described by IEC 60947-5-1, that are installed and mounted in a positive mode
- Periodically checking the functional integrity/safety function
- Training the operators, maintenance personnel, and others involved with operating the machine and the safeguarding to recognize and immediately correct all failures



**Note:** Follow the device manufacturer's installation, operation, and maintenance instructions and all relevant regulations. If there are any questions about the device(s) that are connected to the Safety Controller, contact BERNSTEIN AG for assistance.

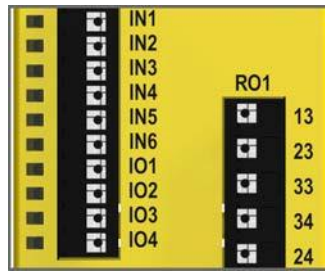

Figure 7: SCR P Input and output terminal locations



**WARNING: Input Device and Safety Integrity**

The Safety Controller can monitor many different safety input devices. The user must conduct a Risk Assessment of the guarding application to determine what Safety Integrity Level needs to be reached in order to know how to properly connect the input devices to the Safety Controller. The user must also take steps to eliminate or minimize possible input signal faults/failures that may result in the loss of the safety functions.

### 6.3.1 Safety Circuit Integrity and ISO 13849-1 Safety Circuit Principles

Safety circuits involve the safety-related functions of a machine that minimize the level of risk of harm. These safety-related functions can prevent initiation, or they can stop or remove a hazard. The failure of a safety-related function or its associated safety circuit usually results in an increased risk of harm.

The integrity of a safety circuit depends on several factors, including fault tolerance, risk reduction, reliable and well-tried components, well-tried safety principles, and other design considerations.

Depending on the level of risk associated with the machine or its operation, an appropriate level of safety circuit integrity (performance) must be incorporated into its design. Standards that detail safety performance levels include ANSI B11.19 Performance Criteria for Safeguarding and ISO 13849-1 Safety-Related Parts of a Control System.

#### Safety Circuit Integrity Levels

Safety circuits in International and European standards have been segmented into Categories and Performance Levels, depending on their ability to maintain their integrity in the event of a failure and the statistical likelihood of that failure. ISO 13849-1 details safety circuit integrity by describing circuit architecture/structure (Categories) and the required performance level (PL) of safety functions under foreseeable conditions.

In the United States, the typical level of safety circuit integrity has been called "Control Reliability". Control Reliability typically incorporates redundant control and self-checking circuitry and has been loosely equated to ISO 13849-1 Category 3 or 4 and/or Performance Level "d" or "e" (see ANSI B11.19).

Perform a risk assessment to ensure appropriate application, interfacing/hookup, and risk reduction (see ANSI B11.0 or ISO 12100). The risk assessment must be performed to determine the appropriate safety circuit integrity in order to ensure that the expected risk reduction is achieved. This risk assessment must take into account all local regulations and relevant standards, such as U.S. Control Reliability or European "C" level standards.

The Safety Controller inputs support up to Category 4 PL e (ISO 13849-1) and Safety Integrity Level 3 (IEC 61508 and IEC 62061) interfacing/hookup. The actual safety circuit integrity level is dependent on the configuration, proper installation of external circuitry, and the type and installation of the safety input devices. The user is responsible for the determination of the overall safety rating(s) and full compliance with all applicable regulations and standards.

The following sections deal only with Category 2, Category 3, and Category 4 applications, as described in ISO 13849-1. The input device circuits shown in the table below are commonly used in safeguarding applications, though other solutions are possible depending on fault exclusion and the risk assessment. The table below shows the input device circuits and the safety category level that is possible if all of the fault detection and fault exclusion requirements are met.



**WARNING: Risk Assessment**

The level of safety circuit integrity can be greatly affected by the design and installation of the safety devices and the means of interfacing of those devices. **A risk assessment must be performed to determine the appropriate level of safety circuit integrity to ensure the expected risk reduction is achieved and all relevant regulations and standards are complied with.**



**WARNING:** Input Devices with dual contact inputs using 2 or 3 terminals

Detection of a short between two input channels (contact inputs, but not complementary contacts) is not possible, if the two contacts are closed. A short can be detected when the input is in the Stop state for at least 2 seconds (see the **INx & IOx input terminals** Tip in [Safety Input Device Options](#) on p. 22).



**WARNING:**

- **Category 2 or 3 Input Shorts**

- It is not possible to detect a short between two input channels (contact inputs, but not complementary contacts) if they are supplied through the same source (for example, the same terminal from the Safety Controller in a dual-channel, 3-terminal hookup, or from an external 24 V supply) and the two contacts are closed.
- Such a short can be detected only when both contacts are open and the short is present for at least 2 seconds.

## Fault Exclusion

An important concept within the requirements of ISO 13849-1 is the probability of the occurrence of a failure, which can be reduced using a technique termed "fault exclusion." The rationale assumes that the possibility of certain well-defined failure(s) can be reduced via design, installation, or technical improbability to a point where the resulting fault(s) can be, for the most part, disregarded—that is, "excluded" in the evaluation.

Fault exclusion is a tool a designer can use during the development of the safety-related part of the control system and the risk assessment process. Fault exclusion allows the designer to design out the possibility of various failures and justify it through the risk assessment process to meet the requirements of ISO 13849-1/-2.

Requirements vary widely for the level of safety circuit integrity in safety applications (that is, Control Reliability or Category/Performance Level) per ISO 13849-1. Although BERNSTEIN always recommends the highest level of safety in any application, it is the responsibility of the user to safely install, operate, and maintain each safety system and comply with all relevant laws and regulations.



**WARNING: Risk Assessment**

The level of safety circuit integrity can be greatly affected by the design and installation of the safety devices and the means of interfacing of those devices. **A risk assessment must be performed to determine the appropriate level of safety circuit integrity to ensure the expected risk reduction is achieved and all relevant regulations and standards are complied with.**

## 6.3.2 Safety Input Device Properties

The Safety Controller is configured via the Software to accommodate many types of safety input devices. See [Adding Inputs and Status Outputs](#) on p. 52 for more information on input device configuration.

### Reset Logic: Manual or Automatic Reset



A manual reset may be required for safety input devices by using a Latch Reset Block or configuring a safety output for a latch reset before the safety output(s) they control are permitted to turn back On. This is sometimes referred to as "latch" mode because the safety output "latches" to the Off state until a reset is performed. If a safety input device is configured for automatic reset or "trip" mode, the safety output(s) it controls will turn back On when the input device changes to the Run state (provided that all other controlling inputs are also in the Run state).

### Connecting the Input Devices

The Safety Controller needs to know what device signal lines are connected to which wiring terminals so that it can apply the proper signal monitoring methods, Run and Stop conventions, and timing and fault rules. The terminals are assigned automatically during the configuration process and can be changed manually using the Software.

### Signal Change-of-State Types

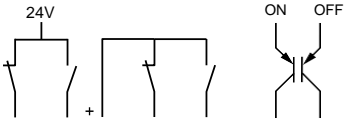
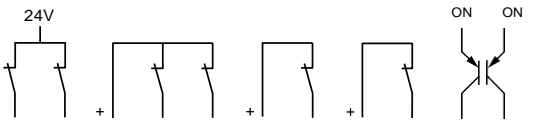
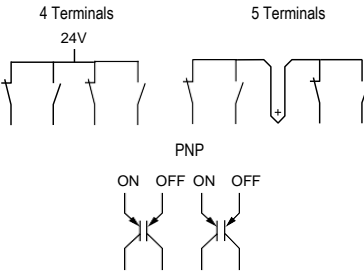
Two change-of-state (COS) types can be used when monitoring dual-channel safety input device signals: Simultaneous or Concurrent.

Input Circuit	Input Signal COS Timing Rules	
	Stop State—SO turns Off when	Run State—SO turns On when
<p><b>Dual-Channel A and B Complementary</b></p> <p>2 Terminals      3 Terminals      2 Terminals, PNP</p> 	<p>At least 1 channel (A or B) input is in the Stop state.</p>	<p><b>Simultaneous:</b> A and B are both in the Stop state and then both switch to the Run state within 3 seconds before outputs turn On.</p> <p><b>Concurrent:</b> A and B concurrently switch to the Stop state, then both switch to the Run state with no simultaneity to turn outputs On.</p>
<p><b>Dual-Channel A and B</b></p> <p>2-Ch, 2 Terminals      2-Ch, 3 Terminals      2-Ch, 4 Terminals      2-Ch, 2 Terminal PNP</p> 		
<p><b>2X Complementary A and B</b></p> <p>4 Terminals      5 Terminals</p> 	<p>At least 1 channel (A or B) within a pair of contacts is in the Stop state.</p>	<p><b>Simultaneous:</b> A and B are concurrently in the Stop state, then the contacts within a channel switch to the Run state within 400 ms (150 ms for two-hand control), both channels are in the Run state within 3 seconds (0.5 seconds for two-hand control).</p> <p><b>Concurrent:</b> A and B are concurrently in the Stop state, then contacts within a channel in the Run state within 3 seconds. There is no simultaneity requirement between the switching of channel A and channel B.</p>
<p><b>4-Wire Safety Mat</b></p> <p>2-Ch, 4 Terminals</p> 	<p>One of the following conditions is met:</p> <ul style="list-style-type: none"> <li>• Input channels are shorted together (normal operation)</li> <li>• At least 1 of the wires is disconnected</li> <li>• One of the normally low channels is detected high</li> <li>• One of the normally high channels is detected low</li> </ul>	<p>Each channel detects its own pulses.</p>

## Signal Debounce Times

**Closed-to-Open Debounce Time (from 6 ms to 1000 ms in 1 ms intervals, except 6 ms to 1500 ms for mute sensors).** The closed-to-open debounce time is the time limit required for the input signal to transition from the high (24 V dc) state to the steady low (0 V dc) state. This time limit may need to be increased in cases where high-magnitude device vibration, impact shock, or switch noise conditions result in a need for longer signal transition times. If the debounce time is set too short under these harsh conditions, the system may detect a signal disparity fault and lock out. The default setting is 6 ms.



### CAUTION: Debounce and Response

**Any changes in the debounce times may affect the Safety Output response (turn Off) time.** This value is computed and displayed for each Safety Output when a configuration is created.

**Open-to-Closed Debounce Time (from 10 ms to 1000 ms in 1 ms intervals, except 10 ms to 1500 ms for mute sensors).** The open-to-closed debounce time is the time limit required for the input signal to transition from the low (0 V DC) state to the steady high (24 V DC) state. This time limit may need to be increased in cases where high magnitude device vibration,

4 Safety Outputs turn Off when one of the controlling inputs is in the Stop state.

5 Safety Outputs turn On only when all of the controlling inputs are in the Run state and after a manual reset is performed (if any safety inputs are configured for Manual reset and were in their Stop state).

impact shock, or switch noise conditions result in a need for longer signal transition times. If the debounce time is set too short under these harsh conditions, the system may detect a signal disparity fault and lock out. The default setting is 50 ms.

## 6.4 Safety Input Device Options

General Circuit Symbols	Circuits shown in Run State							Circuits shown in Stop State	
	ES	GS	OS	RP	PS	SM	DCD	THC	ED
1 & 2 Terminal Single Channel (see note 1)									
2 & 3 Terminal Dual Channel (see note 2)	Cat 2	Cat 2	Cat 2	Cat 2	Cat 2			Type IIIa Cat 1 Type IIIb Cat 3	Cat 3
2 Terminal Dual Channel PNP w/ integral monitoring (see note 3)	Cat 4	Cat 4	Cat 4	Cat 4	Cat 4		Cat 4	Type IIIa Cat 1	Cat 4
3 & 4 Terminal Dual Channel (see notes 2 & 4)	Cat 4	Cat 4	Cat 4	Cat 4	Cat 4			Type IIIa Cat 1 Type IIIb Cat 3	Cat 4
2 & 3 Terminal Dual Channel Complementary		Cat 4	Cat 4	Cat 4	Cat 4				Cat 4
2 Terminal Dual Channel Complementary PNP		Cat 4	Cat 4	Cat 4	Cat 4				Cat 4
4 & 5 Terminal Dual Channel Complementary		Cat 4						Type IIIc Cat 4	Cat 4
4 Terminal Dual Channel Complementary PNP		Cat 4						Type IIIc Cat 4	Cat 4
4 Terminal Safety Mat						Cat 3			

Figure 8: Input Device Circuit—Safety Category Guide



**WARNING: Incomplete Information**—many installation considerations that are necessary to properly apply input devices are not covered in this document. **Refer to the appropriate device installation instructions to ensure the safe application of the device.**



**WARNING:** This table lists the highest safety categories possible for common safety rated input device circuits. If the additional requirements stated in the notes below are not possible due to safety device or installation limitations, or if, for example, the Safety Controller's IOx input terminals are all in use, then the highest safety category may not be possible.



**Tip: INx & IOx input terminals**, these circuits can be manually configured to meet Category 4 circuit requirements by changing the first (left most) standard input terminal (INx) to any available convertible terminal (IOx) as shown below. These circuits will detect shorts to other power sources and between channels when the input has been in the Stop state for at least 2 seconds.

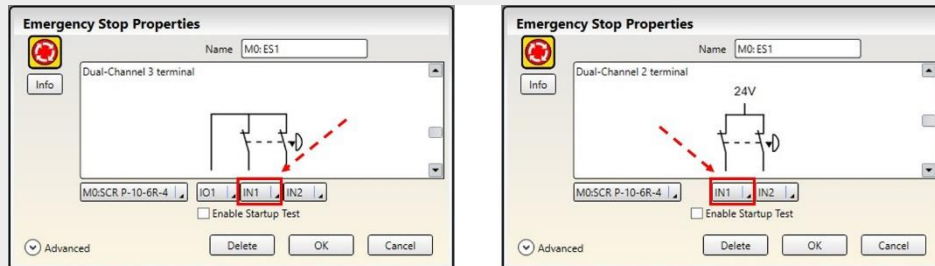

### Notes:

1. Circuit typically meets up to ISO 13849-1 Category 2 if input devices are safety rated and fault exclusion wiring practices prevent a) shorts across the contacts or solid state devices and b) shorts to other power sources.
2. Circuit typically meets up to ISO 13849-1 Category 3 if input devices are safety rated (see **Tip: INx & IOx input terminals** above).  
The 2 Terminal circuit detects a single channel short to other power sources when the contacts open and close

again (concurrency fault).

The 3 Terminal circuit detects a short to other power sources whether the contacts are open or closed.

3. Circuit meets up to ISO 13849-1 Category 4 if input devices are safety rated and provide internal monitor of the PNP outputs to detect a) shorts across channels and b) shorts to other power sources.
4. Circuit meets up to ISO 13849-1 Category 4 if input devices are safety rated (see **Tip: INx & IOx input terminals** above). These circuits can detect both shorts to other power sources and shorts between channels.

## 6.4.1 Safety Circuit Integrity Levels

The application requirements for safeguarding devices vary for the level of control reliability or safety category per ISO 13849-1. While BERNSTEIN always recommends the highest level of safety in any application, the user is responsible to safely install, operate, and maintain each safety system and comply with all relevant laws and regulations.

The safety performance (integrity) must reduce the risk from identified hazards as determined by the machine's risk assessment. See [Safety Circuit Integrity and ISO 13849-1 Safety Circuit Principles](#) on p. 19 for guidance if the requirements as described by ISO 13849-1 need to be implemented.

## 6.4.2 Emergency Stop Push Buttons



The Safety Controller safety inputs may be used to monitor Emergency Stop (E-stop) push buttons.



### WARNING:

- **Do not mute or bypass any emergency stop device**
- Muting or bypassing the safety outputs renders the emergency stop function ineffective.
- ANSI B11.19, ANSI NFPA79 and IEC/EN 60204-1 require that the emergency stop function remain active at all times.



**WARNING:** The Safety Controller Emergency Stop configuration prevents muting or bypassing of the E-stop input(s). However, the user still must ensure that the E-stop device remains active at all times.



### WARNING: Reset Routine Required

U.S. and international standards require that a reset routine be performed after clearing the cause of a stop condition (for example, arming an E-stop button, closing an interlocked guard, etc.). **Allowing the machine to restart without actuating the normal start command/device can create an unsafe condition which could result in serious injury or death.**

In addition to the requirements stated in this section, the design and installation of the Emergency Stop device must comply with ANSI NFPA 79 or ISO 13850. The stop function must be either a functional stop Category 0 or a Category 1 (see ANSI NFPA79).

## Emergency Stop Push Button Requirements

E-stop switch must provide one or two contacts for safety which are closed when the switch is armed. When activated, the E-stop switch must open all its safety-rated contacts and must require a deliberate action (such as twisting, pulling, or unlocking) to return to the closed-contact, armed position. The switch must be a positive-opening (or direct-opening) type, as described by IEC 60947-5-1. A mechanical force applied to such a button (or switch) is transmitted directly to the contacts, forcing them to open. This ensures that the switch contacts open whenever the switch is activated.

Standards ANSI NFPA 79, ANSI B11.19, IEC/EN 60204-1, and ISO 13850 specify additional Emergency Stop switch device requirements, including the following:

- Emergency Stop push buttons must be located at each operator control station and at other operating stations where emergency shutdown is required
- Stop and Emergency Stop push buttons must be continuously operable and readily accessible from all control and operating stations where located. **Do not mute or bypass any E-stop button**
- Actuators of Emergency Stop devices must be colored red. The background immediately around the device actuator must be colored yellow. The actuator of a push-button-operated device must be of the palm or mushroom-head type
- The Emergency Stop actuator must be a self-latching type



**Note:** Some applications may have additional requirements; the user is responsible to comply with all relevant regulations.

## 6.4.3 Rope (Cable) Pull



Rope (cable) pull emergency stop switches use steel wire rope; they provide emergency stop actuation continuously over a distance, such as along a conveyor.

Rope pull emergency stop switches have many of the same requirements as emergency stop push buttons, such as positive (direct) opening operation, as described by IEC 60947-5-1. See [Emergency Stop Push Buttons](#) on p. 23 for additional information.

In emergency stop applications, the rope pull switches must have the capability not only to react to a pull in any direction, but also to a slack or a break of the rope. Emergency stop rope pull switches also need to provide a latching function that requires a manual reset after actuation.

### Rope (Cable) Pull Installation Guidelines

ANSI NFPA 79, ANSI B11.19, IEC/EN 60204-1, and ISO 13850 specify emergency stop requirements for rope (cable) pull installations, including the following:

- Rope (cable) pulls must be located where emergency shutdown is required
- Rope (cable) pulls must be continuously operable, easily visible, and readily accessible. Do not mute or bypass
- Rope (cable) pulls must provide constant tension of the rope or cable pull
- The rope or cable pull, as well as any flags or markers, must be colored Red
- The rope or cable pull must have the capability to react to a force in any direction
- The switch must:
  - Have a self-latching function that requires a manual reset after actuation
  - Have a direct opening operation
  - Detect a slack condition or a break of the rope or cable

#### Additional installation guidelines:

- The wire rope should be easily accessible, red in color for E-Stop functions, and visible along its entire length. Markers or flags may be fixed on the rope to increase its visibility
- Mounting points, including support points, must be rigid and allow sufficient space around the rope to allow easy access
- The rope should be free of friction at all supports. Pulleys are recommended. Lubrication may be necessary. Contamination of the system, such as dirt, metal chips or swarf, etc., must be prevented from adversely affecting operation
- Use only pulleys (not eye bolts) when routing the rope around a corner or whenever direction changes, even slightly
- Never run rope through conduit or other tubing
- Never attach weights to the rope
- A tensioning spring is recommended to ensure compliance with direction-independent actuation of the wire rope and must be installed on the load bearing structure (machine frame, wall, etc.)
- Temperature affects rope tension. The wire rope expands (lengthens) when temperature increases, and contracts (shrinks) when temperature decreases. Significant temperature variations require frequent checks of the tension adjustment



**WARNING:** Failure to follow the installation guidelines and procedures may result in the ineffectiveness or non-operation of the Rope Pull system and create an unsafe condition resulting in a serious injury or death.

## 6.4.4 Enabling Device



An enabling device is a manually operated control which, when continuously actuated, allows a machine cycle to be initiated in conjunction with a start control. Standards that cover the design and application of enabling devices include: ISO 12100-1/-2, IEC 60204-1, ANSI/NFPA 79, ANSI/RIA R15.06, and ANSI B11.19.

The enabling device actively controls the suspension of a Stop signal during a portion of a machine operation where a hazard may occur. The enabling device permits a hazardous portion of the machine to run, but must not start it. An enabling device can control one or more safety outputs. When the enable signal switches from the Stop state to the Run state, the Safety Controller enters the Enable mode. A separate machine command signal from another device is needed to start the hazardous motion. **This enabling device must have ultimate hazard turn Off or Stop authority.**

## 6.4.5 Protective (Safety) Stop



A Protective (Safety) Stop is designed for the connection of miscellaneous devices that could include safeguarding (protective) devices and complementary equipment. This stop function is a type of interruption of operation that allows an orderly cessation of motion for safeguarding purposes. The function can be reset or activated either automatically or manually.



## Protective (Safety) Stop Requirements

The required safety circuit integrity level is determined by a risk assessment and indicates the level of control performance that is acceptable, for example, category 4, Control Reliability (see [Safety Circuit Integrity and ISO 13849-1 Safety Circuit Principles](#) on p. 19). The protective stop circuit must control the safeguarded hazard by causing a stop of the hazardous situation(s) and removing power from the machine actuators. This functional stop typically meets category 0 or 1 as described by ANSI NFPA 79 and IEC60204-1.

### 6.4.6 Interlocked Guard or Gate



The Safety Controller safety inputs may be used to monitor electrically interlocked guards or gates.

### Safety Interlock Switch Requirements

The following general requirements and considerations apply to the installation of interlocked guards and gates for the purpose of safeguarding. In addition, the user must refer to the relevant regulations to ensure compliance with all necessary requirements.

Hazards guarded by the interlocked guard must be prevented from operating until the guard is closed; a stop command must be issued to the guarded machine if the guard opens while the hazard is present. Closing the guard must not, by itself, initiate hazardous motion; a separate procedure must be required to initiate the motion. The safety interlock switches must not be used as a mechanical or end-of-travel stop.

The guard must be located an adequate distance from the danger zone (so that the hazard has time to stop before the guard is opened sufficiently to provide access to the hazard), and it must open either laterally or away from the hazard, not into the safeguarded area. The guard also should not be able to close by itself and activate the interlocking circuitry. In addition, the installation must prevent personnel from reaching over, under, around, or through the guard to the hazard. Any openings in the guard must not allow access to the hazard (see OSHA 29CFR1910.217 Table O-10, ANSI B11.19, ISO 13857, ISO14120/EN953 or the appropriate standard). The guard must be strong enough to contain hazards within the guarded area, which may be ejected, dropped, or emitted by the machine.

The safety interlock switches, actuators, sensors, and magnets must be designed and installed so that they cannot be easily defeated. They must be mounted securely so that their physical position cannot shift, using reliable fasteners that require a tool to remove them. Mounting slots in the housings are for initial adjustment only; final mounting holes must be used for permanent location.



#### **WARNING: Perimeter Guarding Applications**

If the application could result in a pass-through hazard (for example, perimeter guarding), either the safeguarding device or the guarded machine's MSCs/MPCEs must cause a Latched response following a Stop command (for example, interruption of the sensing field of a light curtain, or opening of an interlocked gate/guard). The reset of this Latched condition may only be achieved by actuating a reset switch that is separate from the normal means of machine cycle initiation. The switch must be positioned as described in this document.

Lockout/Tagout procedures per ANSI Z244.1 may be required, or additional safeguarding, as described by ANSI B11 safety requirements or other appropriate standards, must be used if a passthrough hazard cannot be eliminated or reduced to an acceptable level of risk. **Failure to follow these instructions could result in serious injury or death.**

### 6.4.7 Optical Sensor



The Safety Controller safety inputs may be used to monitor optical-based devices that use light as a means of detection.

### Optical Sensor Requirements

When used as safeguarding devices, optical sensors are described by IEC61496-1/-2/-3 as Active Opto-electronic Protective Devices (AOPD) and Active Opto-electronic Protective Devices responsive to Diffuse Reflection (AOPDDR).

AOPDs include safety light screens (curtains) and safety grids and points (multiple-/single-beam devices). These devices generally meet Type 2 or Type 4 design requirements. A Type 2 device is allowed to be used in a Category 2 application, per ISO 13849-1, and a Type 4 device can be used in a Category 4 application.

AOPDDRs include area or laser scanners. The primary designation for these devices is a Type 3, for use in up to Category 3 applications.

Optical safety devices must be placed at an appropriate safety distance (minimum distance), according to the application standards. Refer to the applicable standards and to manufacturer documentation specific to your device for the appropriate calculations. The response time of the Safety Controller outputs to each safety input is provided on the **Configuration Summary** tab in the Software.

If the application includes a pass-through hazard (a person could pass through the optical device beams and stand undetected on the hazard side), other safeguarding may be required, and manual reset should be selected (see [Manual Reset Input](#) on p. 36).

## 6.4.8 Two-Hand Control



The Safety Controller may be used as an initiation device for most powered machinery when machine cycling is controlled by a machine operator.

The Two-Hand Control (THC) actuators must be positioned so that hazardous motion is completed or stopped before the operator can release one or both of the buttons and reach the hazard (see [Two-Hand Control Safety Distance \(Minimum Distance\)](#) on p. 27).

The Safety Controller safety inputs used to monitor the actuation of the hand controls for two-hand control comply with the functionality of Type III requirements of IEC 60204-1 and ISO 13851 (EN 574) and the requirements of ANSI NFPA79 and ANSI B11.19 for two-hand control, which include:

- Simultaneous actuation by both hands within a 500 ms time frame
- When this time limit is exceeded, both hand controls must be released before operation is initiated
- Continuous actuation during a hazardous condition
- Cessation of the hazardous condition if either hand control is released
- Release and re-actuation of both hand controls to re-initiate the hazardous motion or condition (anti-tie down)
- The appropriate performance level of the safety-related function (Control Reliability, Category/Performance level, or appropriate regulation and standard, or Safety Integration Level) as determined by a risk assessment



### **WARNING: Point-of-Operation Guarding**

When properly installed, a two-hand control device provides protection only for the hands of the machine operator. **It may be necessary to install additional safeguarding**, such as safety light screens, additional two-hand controls, and/or hard guards, **to protect all individuals from hazardous machinery.**

**Failure to properly guard hazardous machinery can result in a dangerous condition which could lead to serious injury or death.**



### **CAUTION: Hand Controls**

**The environment in which hand controls are installed must not adversely affect the means of actuation.** Severe contamination or other environmental influences may cause slow response or false ON conditions of mechanical or ergonomic buttons. **This may result in exposure to a hazard.**

The level of safety achieved (for example, ISO 13849-1 Category) depends in part on the circuit type selected.

Consider the following when installing hand controls:

- Failure modes, such as a short circuit, a broken spring, or a mechanical seizure, that may result in not detecting the release of a hand control
- Severe contamination or other environmental influences that may cause a slow response when released or false ON condition of the hand control(s), for example, sticking of a mechanical linkage
- Protection from accidental or unintended operation, for example, mounting position, rings, guards, or shields
- Minimizing the possibility of defeat, for example, hand controls must be far enough apart so that they cannot be operated by the use of one arm—typically, not less than 550 mm (21.7 in) in a straight line, per ISO 13851
- The functional reliability and installation of external logic devices
- Proper electrical installation per NEC and NFPA79 or IEC 60204



### **CAUTION: Install Hand Controls to Prevent Accidental Actuation**

Total protection for the two-hand control system from defeat is not possible. However, **the user is required by U.S. and International standards to arrange and protect hand controls to minimize the possibility of defeat or accidental actuation.**

**CAUTION: Machine Control Must Provide Anti-Repeat Control**

Appropriate anti-repeat control must be provided by the machine control and is required by U.S. and International standards for single-stroke or single-cycle machines.

This Bernstein device can be used to assist in accomplishing anti-repeat control, but a risk assessment must be accomplished to determine the suitability of such use.



**Two-Hand Control Safety Distance (Minimum Distance)**

The hand controls operator must not be able to reach the hazardous area with a hand or any other body part before the machine motion ceases. Use the formula below to calculate the safety distance (minimum distance).



**WARNING: Location of Touch Button Controls**

**Hand controls must be mounted a safe distance from moving machine parts, as determined by the appropriate standard.** It must not be possible for the operator or other non-qualified persons to relocate them. **Failure to establish and maintain the required safety distance could result in serious injury or death.**

**U.S. Applications**

The Safety Distance formula, as provided in ANSI B11.19:

**Part-Revolution Clutch Machinery** (the machine and its controls allow the machine to stop motion during the hazardous portion of the machine cycle)

$$D_s = K \times (T_s + T_r) + D_{pf}$$

**For Full-Revolution Clutch Machinery** (the machine and its controls are designed to complete a full machine cycle)

$$D_s = K \times (T_m + T_r + T_h)$$

**D<sub>s</sub>**

the Safety Distance (in inches)

**K**

the OSHA/ANSI recommended hand-speed constant (in inches per second), in most cases is calculated at 63 in/sec, but may vary between 63 in/sec to 100 in/sec based on the application circumstances;

not a conclusive determination; consider all factors, including the physical ability of the operator, when determining the value of K to be used

**T<sub>h</sub>**

the response time of the slowest hand control from the time when a hand disengages that control until the switch opens;

T<sub>h</sub> is usually insignificant for purely mechanical switches. However, T<sub>h</sub> should be considered for safety distance calculation when using electronic or electromechanical (powered) hand controls. For BERNSTEIN Self-checking Touch Buttons (STBs) the response time is 0.02 seconds

**T<sub>m</sub>**

the maximum time (in seconds) the machine takes to cease all motion after it has been tripped. For full revolution clutch presses with only one engaging point, T<sub>m</sub> is equal to the time necessary for one and one-half revolutions of the crankshaft. For full revolution clutch presses with more than one engaging point, T<sub>m</sub> is be calculated as follows:

$$T_m = (1/2 + 1/N) \times T_{cy}$$

**N** = number of clutch engaging points per revolution

**T<sub>cy</sub>** = time (in seconds) necessary to complete one revolution of the crankshaft

**T<sub>r</sub>**

the response time of the Safety Controller as measured from the time a stop signal from either hand control. The Safety Controller response time is obtained from the **Configuration Summary** tab in the Software.

**T<sub>s</sub>**

the overall stop time of the machine (in seconds) from the initial stop signal to the final ceasing of all motion, including stop times of all relevant control elements and measured at maximum machine velocity

T<sub>s</sub> is usually measured by a stop-time measuring device. If the specified machine stop time is used, add at least 20% as a safety factor to account for brake system deterioration. If the stop-time of the two redundant machine control elements is unequal, the slower of the two times must be used for calculating the separation distance

## European Applications

The Minimum Distance Formula, as provided in EN 13855:

$$S = (K \times T) + C$$

**S**

the Minimum Distance (in millimeters)

**K**

the EN 13855 recommended hand-speed constant (in millimeters per second), in most cases is calculated at 1600 mm/sec, but may vary between 1600 to 2500 mm/sec based on the application circumstances;

not a conclusive determination; consider all factors, including the physical ability of the operator, when determining the value of K to be used.

**T**

the overall machine stopping response time (in seconds), from the physical initiation of the safety device to the final ceasing of all motion

**C**

the added distance due to the depth penetration factor equals 250 mm, per EN 13855. The EN 13855 **C** factor may be reduced to 0 if the risk of encroachment is eliminated, but the safety distance must always be 100 mm or greater

## 6.4.9 Safety Mat



The Safety Controller may be used to monitor pressure-sensitive safety mats and safety edges.

The purpose of the Safety Mat input of the Safety Controller is to verify the proper operation of 4-wire, presence-sensing safety mats. Multiple mats may be connected in series to one Safety Controller, 150 ohms maximum per input (see [Safety Mat Hookup Options](#) on p. 31).



**Important:** The Safety Controller is not designed to monitor 2-wire mats, bumpers, or edges (with or without sensing resistors).

The Safety Controller monitors the contacts (contact plates) and the wiring of one or more safety mat(s) for failures and prevents the machine from restarting if a failure is detected. A reset routine after the operator steps off the safety mat may be provided by the Safety Controller, or, if the Safety Controller is used in auto-reset mode, the reset function must be provided by the machine control system. This prevents the controlled machinery from restarting automatically after the mat is cleared.



### WARNING:

**Application of Safety Mats** — Safety Mat application requirements vary for the level of control reliability or category and performance level as described by ISO 13849-1 and ISO 13856. Although Bernstein Engineering always recommends the highest level of safety in any application, the user is responsible to safely install, operate, and maintain each safety system per the manufacturer's recommendations and comply with all relevant laws and regulations.

Do not use safety mats as a tripping device to initiate machine motion (such as in a presence-sensing device initiation application), due to the possibility of unexpected start or re-start of the machine cycle resulting from failure(s) within the mat and the interconnect cabling.

Do not use a safety mat to enable or provide the means to allow the machine control to start hazardous motion by simply standing on the safety mat (for example, at a control station). This type of application uses reverse/negative logic and certain failures (for example, loss of power to the Module) can result in a false enable signal.

## Safety Mat Requirements

The following are minimum requirements for the design, construction, and installation of four-wire safety mat sensor(s) to be interfaced with the Safety Controller. These requirements are a summary of standards ISO 13856-1, ANSI/RIA R15.06 and ANSI B11.19. The user must review and comply with all applicable regulations and standards.

### Safety Mat System Design and Construction

The safety mat system sensor, Safety Controller, and any additional devices must have a response time that is fast enough to reduce the possibility of an individual stepping lightly and quickly over the mat's sensing surface (less than 100 to 200 ms, depending on the relevant standard).

For a safety mat system, the minimum object sensitivity of the sensor must detect, at a minimum, a 30 kg (66 lb) weight on an 80 mm (3.15 in) diameter circular disk test piece anywhere on the mat's sensing surface, including joints and junctions. The effective sensing surface or area must be identifiable and can comprise one or more sensors. The safety mat supplier should state this minimum weight and diameter as the minimum object sensitivity of the sensor.

User adjustments to actuating force and response time are not allowed (ISO 13856-1). The sensor should be manufactured to prevent any reasonably foreseeable failures, such as oxidation of the contact elements which could cause a loss in sensitivity.

The environmental rating of the sensor must meet a minimum of IP54. When the sensor is specified for immersion in water, the sensor's minimum enclosure level must be IP67. The interconnect cabling may require special attention. A wicking action may result in the ingress of liquid into the mat, possibly causing a loss of sensor sensitivity. The termination of the interconnect cabling may need to be located in an enclosure that has an appropriate environmental rating.

The sensor must not be adversely affected by the environmental conditions for which the system is intended. The effects of liquids and other substances on the sensor must be taken into account. For example, long-term exposure to some liquids can cause degradation or swelling of the sensor's housing material, resulting in an unsafe condition.

The sensor's top surface should be a lifetime non-slip design, or otherwise minimize the possibility of slipping under the expected operating conditions.

The four-wire connection between the interconnect cables and the sensor must withstand dragging or carrying the sensor by its cable without failing in an unsafe manner, such as broken connections due to sharp or steady pulls, or continuous flexing. If such connection is not available, an alternative method must be employed to avoid such failure, for example, a cable which disconnects without damage and results in a safe situation.

## Safety Mat Installation

The mounting surface quality and preparation for the safety mat must meet the requirements stated by the sensor's manufacturer. Irregularities in the mounting surfaces may impair the function of the sensor and should be reduced to an acceptable minimum. The mounting surface should be level and clean. Avoid the collection of fluids under or around the sensor. Prevent the risk of failure due to a build-up of dirt, turning chips, or other material under the sensor(s) or the associated hardware. Special consideration should be given to joints between the sensors to ensure that foreign material does not migrate under or into the sensor.

Any damage (cuts, tears, wear, or punctures) to the outer insulating jacket of the interconnect cable or to any part of the exterior of the safety mat must be immediately repaired or replaced. Ingress of material (including dirt particles, insects, fluid, moisture, or turning-chips), which may be present near the mat, may cause the sensor to corrode or to lose its sensitivity.

Routinely inspect and test each safety mat according to the manufacturer's recommendations. Do not exceed operational specifications, such as the maximum number of switching operations.

Securely mount each safety mat to prevent inadvertent movement (creeping) or unauthorized removal. Methods include, but are not limited to, secured edging or trim, tamper-resistant or one-way fasteners, and recessed flooring or mounting surface, in addition to the size and weight of large mats.

Each safety mat must be installed to minimize tripping hazards, particularly towards the machine hazard. A tripping hazard may exist when the difference in height of an adjacent horizontal surface is 4 mm (1/8 in) or more. Minimize tripping hazards at joints, junctions, and edges, and when additional coverings are used. Methods include a ground-flush installation of the mat, or a ramp that does not exceed 20° from horizontal. Use contrasting colors or markings to identify ramps and edges.

Position and size the safety mat system so that persons cannot enter the hazardous area without being detected and cannot reach the hazard before the hazardous conditions have ceased. Additional guards or safeguarding devices may be required to ensure that exposure to the hazard(s) is not possible by reaching over, under, or around the device's sensing surface.

A safety mat installation must take into account the possibility of easily stepping over the sensing surface and not being detected. ANSI and international standards require a minimum depth of field of the sensor surface (the smallest distance between the edge of the mat and hazard) to be from 750 to 1200 mm (30 to 48 in), depending on the application and the relevant standard. The possibility of stepping on machine supports or other physical objects to bypass or climb over the sensor also must be prevented.

## Safety Mat Safety Distance (Minimum Distance)

As a stand-alone safeguard, the safety mat must be installed at a safety distance (minimum distance) so that the exterior edge of the sensing surface is at or beyond that distance, unless it is solely used to prevent start/restart, or solely used for clearance safeguarding (see ANSI B11.19, ANSI/RIA R15.06, and ISO 13855).

The safety distance (minimum distance) required for an application depends on several factors, including the speed of the hand (or individual), the total system stopping time (which includes several response time components), and the depth penetration factor. Refer to the relevant standard to determine the appropriate distance or means to ensure that individuals cannot be exposed to the hazard(s).

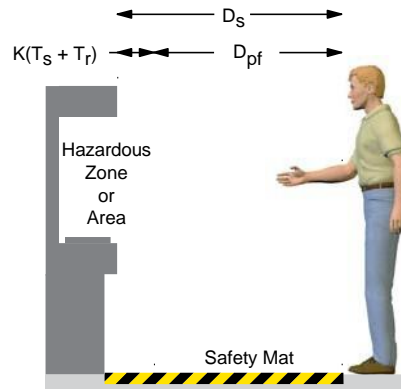

Figure 9: Determining safety distance for the safety mat

### U.S. Applications

The Safety Distance formula, as provided in ANSI B11.19:

$$D_s = K \times (T_s + T_r) + D_{pf}$$

#### $D_s$

the Safety Distance (in inches)

#### $T_r$

the response time of the Safety Controller as measured from the time a stop signal from either hand control. The Safety Controller response time is obtained from the **Configuration Summary** tab in the Software.

#### $K$

the OSHA/ANSI recommended hand-speed constant (in inches per second), in most cases is calculated at 63 in/sec, but may vary between 63 in/sec to 100 in/sec based on the application circumstances;

not a conclusive determination; consider all factors, including the physical ability of the operator, when determining the value of K to be used

#### $T_s$

the overall stop time of the machine (in seconds) from the initial stop signal to the final ceasing of all motion, including stop times of all relevant control elements and measured at maximum machine velocity

$T_s$  is usually measured by a stop-time measuring device. If the specified machine stop time is used, add at least 20% as a safety factor to account for brake system deterioration. If the stop-time of the two redundant machine control elements is unequal, the slower of the two times must be used for calculating the separation distance

#### $D_{pf}$

the added distance due to the penetration depth factor

equals 48 in, per ANSI B11.19

### European Applications

The Minimum Distance Formula, as provided in EN 13855:

$$S = (K \times T) + C$$

#### $S$

the Minimum Distance (in millimeters)

#### $K$

the EN 13855 recommended hand-speed constant (in millimeters per second), in most cases is calculated at 1600 mm/sec, but may vary between 1600 to 2500 mm/sec based on the application circumstances;

not a conclusive determination; consider all factors, including the physical ability of the operator, when determining the value of K to be used.

#### $T$

the overall machine stopping response time (in seconds), from the physical initiation of the safety device to the final ceasing of all motion

European Applications

C

the added distance due to the depth penetration factor equals 1200 mm, per EN 13855

## Safety Mat Hookup Options

Pressure-sensitive mats and pressure-sensitive floors must meet the requirements of the category for which they are specified and marked. These categories are defined in ISO 13849-1.

The safety mat, its Safety Controller, and any output signal switching devices must meet, at a minimum, the Category 1 safety requirements. See ISO 13856-1 (EN 1760-1) and ISO 13849-1 for relevant requirement details.

**The Safety Controller is designed to monitor 4-wire safety mats and is not compatible with two-wire devices** (mats, sensing edges, or any other devices with two wires and a sensing resistor).

### 4-Wire

This circuit typically meets ISO 13849-1 Category 2 or Category 3 requirements depending on the safety rating and installation of the mat(s). The Safety Controller enters a Lockout mode when an open wire, a short to 0 V, or a short to another source of power is detected.

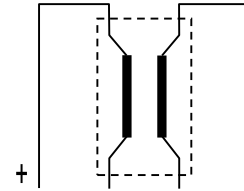

## 6.4.10 Muting Sensor



Safety device muting is an automatically controlled suspension of one or more safety input stop signals during a portion of a machine operation when no immediate hazard is present or when access to the hazard is safeguarded. Muting sensors can be mapped to one or more of the following safety input devices:

- Safety gate (interlocking) switches
- Optical sensors
- Two-hand controls
- Safety mats
- Protective stops

US and International standards require the user to arrange, install, and operate the safety system so that personnel are protected and the possibility of defeating the safeguard is minimized.

## Examples of Muting Sensors and Switches



### WARNING: Avoid Hazardous Installations

**Two or four independent position switches must be properly adjusted or positioned so that they close only after the hazard no longer exists, and open again when the cycle is complete or the hazard is again present. If the switches are improperly adjusted or positioned, injury or death may result.**

The user is responsible to satisfy all local, state, and national laws, rules, codes, and regulations relating to the use of safety equipment in any particular application. Make sure that all appropriate agency requirements have been met and that all installation and maintenance instructions contained in the appropriate manuals are followed.

### Photoelectric Sensors (Opposed Mode)

Opposed-mode sensors should be configured for dark operate (DO) and have open (non-conducting) output contacts in a power Off condition. Both the emitter and receiver from each pair should be powered from the same source to reduce the possibility of common mode failures.

### Photoelectric Sensors (Polarized Retroreflective Mode)

The user must ensure that false proxying (activation due to shiny or reflective surfaces) is not possible. BERNSTEIN low profile sensors with linear polarization can greatly reduce or eliminate this effect.

Use a sensor configured for light operate (LO or N.O.) if initiating a mute when the retroreflective target or tape is detected (home position). Use a sensor configured for dark operate (DO or N.C.) when a blocked beam path initiates the muted condition (entry/exit). Both situations must have open (non-conducting) output contacts in a power Off condition.

## Positive-Opening Safety Switches

Two (or four) independent switches, each with a minimum of one closed safety contact to initiate the mute cycle, are typically used. An application using a single switch with a single actuator and two closed contacts may result in an unsafe situation.

## Inductive Proximity Sensors

Typically, inductive proximity sensors are used to initiate a muted cycle when a metal surface is detected. Do not use two-wire sensors due to excessive leakage current causing false On conditions. Use only three- or four-wire sensors that have discrete PNP or hard-contact outputs that are separate from the input power.

## Mute Device Requirements

The muting devices must, at a minimum, comply with the following requirements:

1. There must be a minimum of two independent hard-wired muting devices.
2. The muting devices must have one of the following: normally open contacts, PNP outputs (both of which must fulfill the input requirements listed in the [Specifications and Requirements](#) on p. 12), or a complementary switching action. At least one of these contacts must close when the switch is actuated, and must open (or not conduct) when the switch is not actuated or is in a power-off state.
3. The activation of the inputs to the muting function must come from separate sources. These sources must be mounted separately to prevent an unsafe muting condition resulting from misadjustment, misalignment, or a single common mode failure, such as physical damage to the mounting surface. Only one of these sources may pass through, or be affected by, a PLC or a similar device.
4. The muting devices must be installed so that they cannot be easily defeated or bypassed.
5. The muting devices must be mounted so that their physical position and alignment cannot be easily changed.
6. It must not be possible for environmental conditions, such as extreme airborne contamination, to initiate a mute condition.
7. The muting devices must not be set to use any delay or other timing functions unless such functions are accomplished so that no single component failure prevents the removal of the hazard, subsequent machine cycles are prevented until the failure is corrected, and no hazard is created by extending the muted period.

### 6.4.11 Bypass Switch



The safety device bypass is a manually activated and temporary suspension of one or more safety input stop signals, under supervisory control, when no immediate hazard is present. It is typically accomplished by selecting a bypass mode of operation using a key switch to facilitate machine setup, web alignment/adjustments, robot teach, and process troubleshooting.

Bypass switches can be mapped to one or more of the following safety input devices:

- Safety gate (interlocking) switches
- Optical sensors
- Two-Hand Controls
- Safety mats
- Protective stop

## Requirements of Bypassing Safeguards

Requirements to bypass a safeguarding device include<sup>®</sup>:

- The bypass function must be temporary
- The means of selecting or enabling the bypass must be capable of being supervised
- Automatic machine operation must be prevented by limiting range of motion, speed, or power (used inch, jog, or slow-speed modes). Bypass mode must not be used for production
- Supplemental safeguarding must be provided. Personnel must not be exposed to hazards
- The means of bypassing must be within full view of the safeguard to be bypassed
- Initiation of motion should only be through a hold-to-run type of control
- All emergency stops must remain active
- The means of bypassing must be employed at the same level of reliability as the safeguard
- Visual indication that the safeguarding device has been bypassed must be provided and be readily observable from the location of the safeguard
- Personnel must be trained in the use of the safeguard and in the use of the bypass
- Risk assessment and risk reduction (per the relevant standard) must be accomplished
- The reset, actuation, clearing, or enabling of the safeguarding device must not initiate hazardous motion or create a hazardous situation

<sup>®</sup> This summary was compiled from sources including ANSI NFPA79, ANSI/RIA R15.06, ISO 13849-1, IEC60204-1, and ANSI B11.19.



Bypassing a safeguarding device should not be confused with *muting*, which is a temporary, automatic suspension of the safeguarding function of a safeguarding device during a non-hazardous portion of the machine cycle. Muting allows for material to be manually or automatically fed into a machine or process without issuing a stop command. Another term commonly confused with bypassing is *blanking*, which desensitizes a portion of the sensing field of an optical safeguarding device, such as disabling one or more beams of a safety light curtain so that a specific beam break is ignored.

### 6.4.12 Adjustable Valve Monitoring (AVM) Function



The Adjustable Valve (Device) Monitoring (AVM) function is similar in function to One-Channel External Device Monitoring (1-channel EDM, see [External Device Monitoring \(EDM\)](#) on p. 44). The AVM function monitors the state of the device(s) that are controlled by the safety output to which the function is mapped. When the safety output turns Off, the AVM input must be high/On (+24 V dc applied) before the AVM timer expires or a lockout will occur. The AVM input must also be high/On when the safety output attempts to turn On or a lockout will occur.

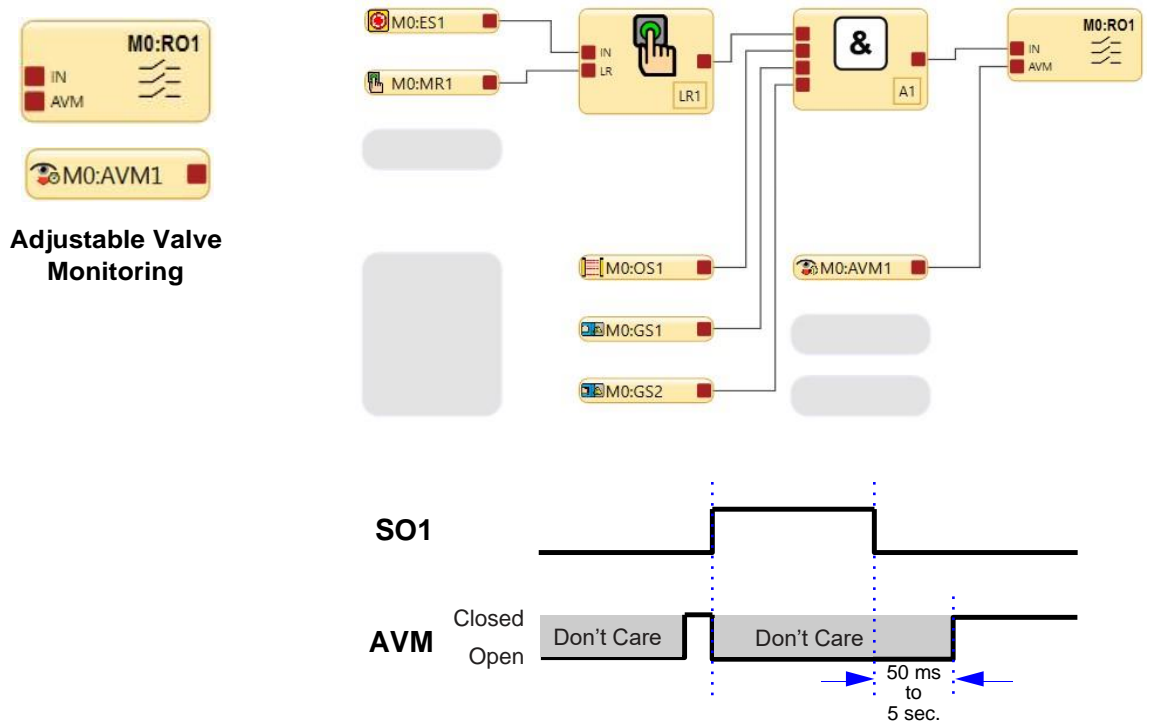

Adjustable Valve Monitoring AVM is a way to check the operation of dual channel valves. The force guided N.C. monitoring contacts of the valves are used as an input to detect a “stuck on” fault condition and will prevent the safety controller outputs from turning On.



**Note:** 50 ms to 5 s time period is adjustable in 50 ms intervals (default is 50 ms).

Figure 10: Timing logic—AVM Function

The Adjustable Valve (Device) Monitoring function is useful for dynamically monitoring devices under the control of the safety output that may become slow, stick, or fail in an energized state or position, and whose operation needs to be verified after a Stop signal occurs. Example applications include single- or dual-solenoid valves controlling clutch/brake mechanisms, and position sensors that monitor the home position of a linear actuator.

Synchronization or checking a maximum differential timing between two or more devices, such as dual valves, may be achieved by mapping multiple AVM functions to one safety output and configuring the AVM timer to the same values. Any number of AVM inputs can be mapped to one safety output. An input signal can be generated by a hard/relay contact or a solid-state PNP output.



**WARNING:**

- **Adjustable Valve Monitoring (AVM) Operation**
- When the AVM function is used, the Safety Output(s) will not turn ON until the AVM input is satisfied. This could result in an ON-delay up to the configured AVM monitoring time.
- It is the user's responsibility to ensure the AVM monitoring time is properly configured for the application and to instruct all individuals associated with the machine about the possibility of the ON-Delay effect, which may not be readily apparent to the machine operator or to other personnel.

## 6.4.13 DCD Inputs



The Safety Controller safety inputs IN3/IN4 and IN5/IN6 may be used to monitor chains of devices with embedded Daisy Chain Diagnostic (DCD) data, such as BERNSTEIN SRF Safety Switches. The BERNSTEIN SRF Safety Switches use RFID technology as a means of detection.

DCD devices, such as SRF Safety Switches, must be placed at an appropriate safety distance (minimum distance), according to the application standards. Refer to the applicable standards and to the documentation specific to the device for the appropriate calculations. The response time of the Safety Controller outputs to each safety input is provided on the **Configuration Summary** tab in the Software. This time must be added to the response time of the DCD chain of devices.

The active DCD devices' solid-state outputs have (and must have) the ability to detect external shorts to power, to ground, or to each other. The devices will lockout if such a short is detected.

If the application includes a pass-through hazard (a person could pass through an opened gate and stand undetected on the hazard side), other safeguarding may be required, and manual reset should be selected. See [Manual Reset Input](#) on p. 36.



**Note:** In a long chain or chains with a lot of DCD devices, the voltage at the first unit (closest to the terminating plug) must stay above 19.5 volts for the chain to operate properly.



**Note:** If the entire chain consists of only door switches, the configuration rules for a gate switch apply.

## 6.5 Non-Safety Input Devices

The non-safety input devices include manual reset devices, On/Off switches, mute enable devices, and cancel delay inputs.

**Manual Reset Devices**—Used to create a reset signal for an output or function block configured for a manual reset, requiring an operator action for the output of that block to turn on. Resets can also be created using virtual reset input; see [Virtual Non-Safety Input Devices](#) on p. 37.



**WARNING: Non-Monitored Resets**

**If a non-monitored reset (either latch or system reset) is configured and if all other conditions for a reset are in place, a short from the Reset terminal to +24 V will turn On the safety output(s) immediately.**

**ON/Off Switch**—Provides an On or Off command to the machine. When all of the controlling safety inputs are in the Run state, this function permits the safety output to turn On and Off. This is a single-channel signal; the Run state is 24 V dc and the Stop state is 0 V dc. An On/Off input can be added without mapping to a safety output, which allows this input to control only a status output. An On/Off switch can also be created using a virtual input; see [Virtual Non-Safety Input Devices](#) on p. 37.

**Mute Enable Switch**—Signals the Safety Controller when the mute sensors are permitted to perform a mute function. When the mute enable function is configured, the mute sensors are not enabled to perform a mute function until the mute enable signal is in the Run state. This is a single-channel signal; the enable (Run) state is 24 V dc and the disable (Stop) state is 0 V dc. A mute enable switch can also be created using a virtual input; see [Virtual Non-Safety Input Devices](#) on p. 37.

**Cancel Off-Delay Devices**—Provide the option to cancel a configured Off-delay time of a safety output or a delay block output. It functions in one of the following ways:

- Keeps the safety output or delay block output On
- Turns the safety output or delay block output Off immediately after the Safety Controller receives a Cancel Off-Delay signal
- When **Cancel Type** is set to "Control Input", the safety output or delay block output stays on if the input turns On again before the end of the delay

A status output function (Output Delay in Progress) indicates when a Cancel Delay Input can be activated in order to keep the Off-delayed safety output On. A cancel off-delay device can also be created using a virtual input; see [Virtual Non-Safety Input Devices](#) on p. 37.

### Cancel Off-Delay Timing

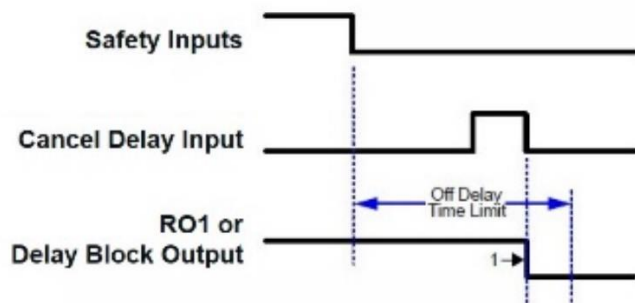

Note 1 - If "turn output off" function is selected

Figure 11: Safety Input remains in Stop mode

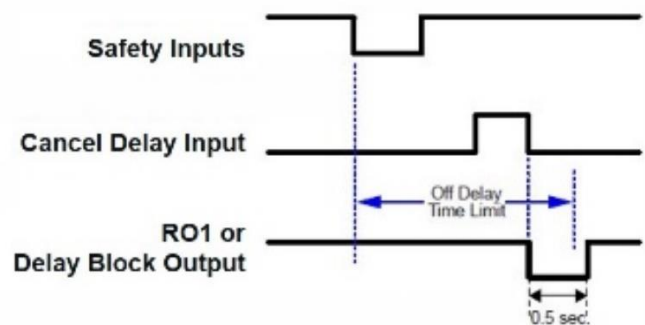

Figure 12: Turn Output Off function

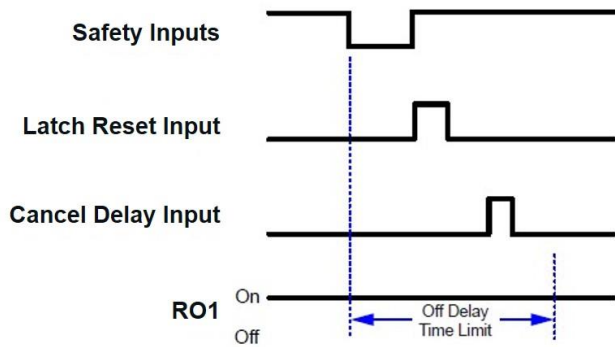

Figure 13: Keep Output On function for Safety Inputs with the Latch Reset

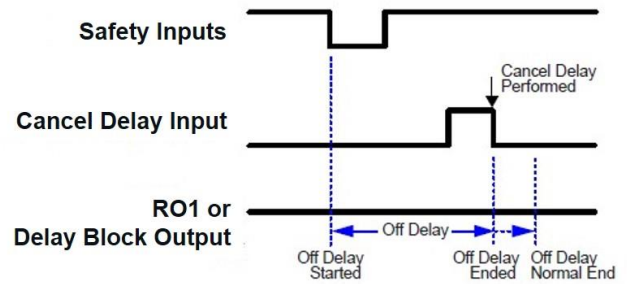

Figure 14: Keep Output On function for Safety Inputs without the Latch Reset

## 6.5.1 Manual Reset Input

The Manual Reset input may be configured to perform any combination of the following (see [Adding Inputs and Status Outputs](#) on p. 52):

### Reset of Safety Inputs

Sets the output of the Latch Reset Block(s) to a Run state from a Latched state when the IN node is in a Run state

### Reset of Safety Outputs

Sets the Output to On if the Output Block configured for Latch Reset is On.

#### Exceptions:

A Safety Output cannot be configured to use a Manual Reset when associated with a Two Hand Control input or an Enabling Device Function Block.

### System Reset

Sets the System to a Run state from a Lockout state due to a system fault. Possible scenarios when System Reset is needed include:

- Signals are detected on unused terminal pins
- Configuration Mode timeout
- Exiting Configuration Mode
- Internal faults



**Note:** A manual reset selected as a system reset can be used to finish the confirmation of a new configuration so that the power does not have to be cycled to the device.

### Output Fault Reset

Clears the fault and allows the output to turn back On if the cause of the fault has been removed. Possible scenarios when an Output Fault Reset is needed include:

- Output faults
- EDM or AVM

### faults Manual Reset on

### Power-Up

Allows various Latch Reset Blocks and/or Output Blocks to be controlled by a single reset input after the power up.

### Enable Mode Exit

A reset is required to exit the Enable Mode.

### Track Input Group Reset

Resets the Status Output function **Track Input Group** and the Virtual Status Output Function **Track Input Group**.

The reset switch must be mounted at a location that complies with the warning below. A key-actuated reset switch provides some operator or supervisory control, as the key can be removed from the switch and taken into the guarded area. However, this does not prevent from any unauthorized or inadvertent resets due to spare keys being in the possession of others, or additional personnel entering the guarded area unnoticed (a pass-through hazard).



**WARNING: Reset Switch Location**

All reset switches must be accessible only from outside, and in full view of, the hazardous area. Reset switches must also be out of reach from within the safeguarded space, and must be protected against unauthorized or inadvertent operation (for example, through the use of rings or guards). If any areas are not visible from the reset switch(es), additional means of safeguarding must be provided. Failure to follow these instructions could result in serious injury or death.



**Important:** Resetting a safeguard must not initiate hazardous motion. Safe work procedures require a start-up procedure to be followed and the individual performing the reset to verify that the entire hazardous area is clear of all personnel before each reset of the safeguard is performed. If any area cannot be observed from the reset switch location, additional supplemental safeguarding must be used: at a minimum, visual and audible warnings of the machine start-up.



**Note: Automatic Reset** sets an output to return to an On state without action by an individual once the input device(s) changes to the Run state and all other logic blocks are in their Run state. Also known as "Trip mode," automatic reset is typically used in applications in which the individual is continually being sensed by the safety input device.



**WARNING: Automatic Power Up**

On power up, the Safety Outputs and Latch Reset Blocks configured for automatic power up will turn their outputs On if all associated inputs are in the Run state. If manual reset is required, configure outputs for a manual power mode.

## Automatic and Manual Reset Inputs Mapped to the Same Safety Output

By default, Safety Outputs are configured for automatic reset (trip mode). They can be configured as a Latch Reset using the Solid State Output Properties attribute of the Safety Output (see [Function Blocks](#) on p. 68).

Safety Input Devices operate as automatic reset unless a Latch Reset Block is added. If a Latch Reset Block is added in line with an output configured for Latch Reset mode, the same or different Manual Reset Input Device(s) may be used to reset the Latch Reset Block and the Safety Output latch. If the same Manual Reset Input Device is used for both, and all inputs are in their Run state, a single reset action will unlatch the function block and the output block. If different Manual Reset Input Devices are used, the reset associated with the Safety Output must be the last one activated. This can be used to force a sequenced reset routine, which can be used to reduce or eliminate pass-through hazards in perimeter guarding applications (see [Safety Input Device Properties](#) on p. 20).

If the controlling inputs to a Latch Reset Block or a Safety Output Block are not in the Run state, the reset for that block will be ignored.

## Reset Signal Requirements

Reset Input devices can be configured for monitored or non-monitored operation, as follows:

**Monitored reset:** Requires the reset signal to transition from low (0 V dc) to high (24 V dc) and then back to low. The high state duration must be 0.5 seconds to 2 seconds. This is called a trailing edge event.

**Non-monitored reset:** Requires only that the reset signal transitions from low (0 V dc) to high (24 V dc) and stays high for at least 0.5 seconds. After the reset, the reset signal can be either high or low. This is called a leading-edge event.

## 6.6 Virtual Non-Safety Input Devices

The virtual non-safety input devices include manual reset, On/Off, mute enable, and cancel off delay.



**WARNING:** Virtual Non-Safety inputs must never be used to control any safety-critical applications.

**Important:** Resetting a safeguard must not initiate hazardous motion. Safe work procedures require a start-up procedure to be followed and the individual performing the reset to verify that the entire hazardous area is clear of all personnel before each reset of the safeguard is performed. If any area cannot be observed from the reset switch location, additional supplemental safeguarding must be used: at a minimum, visual and audible warnings of the machine start-up.



## 6.6.1 Virtual Manual Reset and Cancel Delay (RCD) Sequence

According to section 5.2.2 of EN ISO 13849-1:2015, a "deliberate action" by the operator is required to reset a safety function. Traditionally, this requirement is met by using a mechanical switch and associated wires connected to specified terminals on the Safety Controller. For a monitored reset, the contacts must be open initially, then closed, and then open again within the proper timing. If the timing is not too short or too long, it is determined to be deliberate and the reset is performed.

BERNSTEIN has created a virtual reset solution that requires deliberate action. For example, in place of the mechanical switch, an HMI may be used. In place of the wires, a unique Actuation Code is used for each Safety Controller on a network. Also, each virtual reset within a Safety Controller is associated with a specific bit in a register. This bit, along with the Actuation Code, must be written and cleared in a coordinated way. If the steps are completed with the proper sequence and timing, it is determined to be deliberate and the reset is performed.

While the standards do not require a "deliberate action" to perform a virtual cancel delay, to avoid additional complexity, BERNSTEIN has implemented this function in the same way as the virtual manual reset.

The user must set matching Actuation Codes in both the Safety Controller and the controlling network device (PLC, HMI, etc.). The Actuation Code is part of the Network Settings and is not included in the configuration CRC. There is no default Actuation Code. The user must set one up on the **Network Settings** screen. The Actuation Code can be active for up to 2 seconds for it to be effective. Different Safety Controllers on the same network should have different Actuation Codes.

**Note:** When a virtual manual reset or cancel delay is added in the functional view, the check list adds a note that an actuation code must be entered under **Network Settings**.

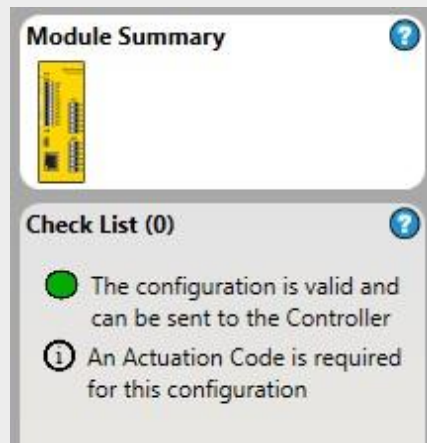

Figure 15: Example Checklist Warning

The HMI/PLC programmer can choose from two different methods depending on their preferences: a feedback-based sequence or a timed sequence. These methods are described in the following figures. The actual register location depends upon which protocol is being used.

### Virtual Reset or Cancel Delay (RCD) Sequence—Feedback Method

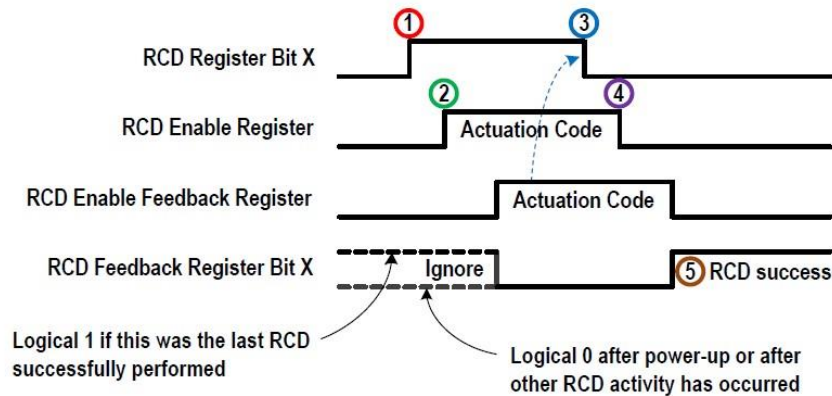

Figure 16: Virtual Reset or Cancel Delay (RCD) Sequence—Feedback Method

1. Write a logical 1 to the RCD Register Bit(s) corresponding to the desired Virtual Reset or Cancel Delay.
2. At the same time, or any time later, write the Actuation Code to the RCD Enable Register.
3. Monitor the RCD Enable Feedback Register for the Actuation Code to appear (125 ms typical). Then write a logical 0 to the RCD Register Bit.
4. At the same time, or any time later, clear the Actuation Code (write a logical 0 to the RCD Enable Register). This step must be completed within 2 seconds of when the code was first written (step 2).
5. If desired, monitor the RCD Feedback Register to know if the desired Reset or Cancel Delay was accepted (175 ms typical).



**Note:** An AOI and PLC function block are available at [www.bernstein.eu](http://www.bernstein.eu).

### Virtual Reset or Cancel Delay (RCD) Sequence—Timed Method

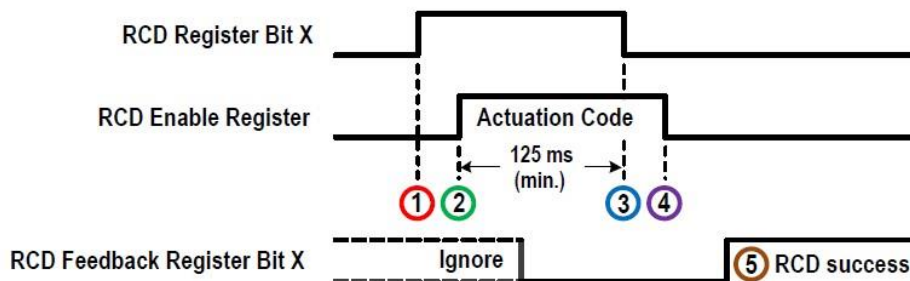

Figure 17: Virtual Reset or Cancel Delay (RCD) Sequence—Timed Method

1. Write a logical 1 to the RCD Register Bit(s) corresponding to the desired Virtual Reset or Cancel Delay.
2. At the same time, or any time later, write the Actuation Code to the RCD Enable Register.
3. At least 125 ms after step 2, write a logical 0 to the RCD Register Bit.
4. At the same time, or any time later, clear the Actuation Code (write a logical 0 to the RCD Enable Register). This step must be completed within 2 seconds from when the code was first written (step 2).
5. If desired, monitor the RCD Feedback Register to know if the desired Reset or Cancel Delay was accepted (175 ms typical).

**Virtual Manual Reset Devices** are used to create a reset signal for an output or function block configured for a manual reset, requiring an operator action for the output of that block to turn on. Resets can also be created using physical reset input: see [Non-Safety Input Devices](#) on p. 35.



**WARNING: Virtual Manual Reset**

Any Virtual Manual Reset configured to perform a Manual Power Up function in conjunction with equipment in several locations on the same network should be avoided unless all hazardous areas can be verified safe.

**Virtual Cancel Off-Delay Devices:** provide the option to cancel a configured Off-delay time. It functions in one of the following ways:

- Keeps the safety output or delay block output On
- Turns the safety output or delay block output Off immediately after the Safety Controller receives a Cancel Off-Delay signal
- When **Cancel Type** is set to "Control Input", the safety output or delay block output stays on if the input turns On again before the end of the delay

A status output function (Output Delay in Progress) indicates when a Cancel Delay Input can be activated in order to keep the Off-delayed safety output On. A cancel off-delay device can also be created using a physical input; see [Non-Safety Input Devices](#) on p. 35.

**Virtual Cancel Off-Delay Timing**

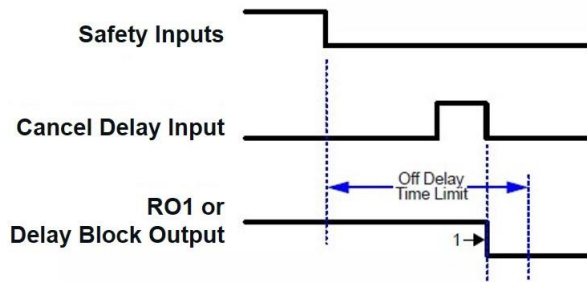

Note 1 - If "turn output off" function is selected

Figure 18: Safety Input remains in Stop mode

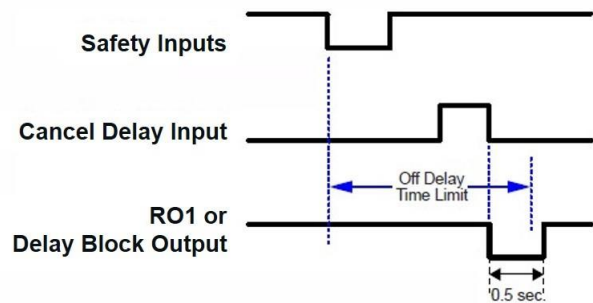

Figure 19: Turn Output Off function

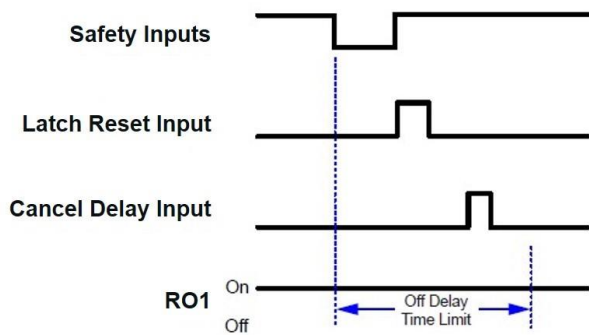

Figure 20: Keep Output On function for Safety Inputs with the Latch Reset

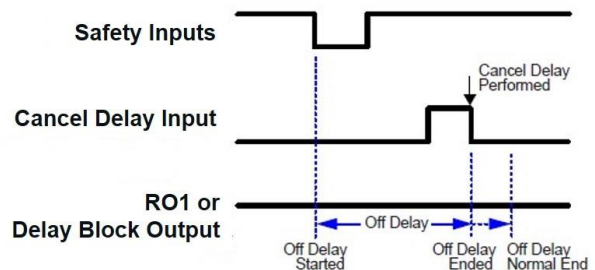

Figure 21: Keep Output On function for Safety Inputs without the Latch Reset



## 6.6.2 Virtual ON/OFF and Mute Enable

### Virtual ON/OFF

Provides an ON or OFF command to the machine. When all of the controlling safety inputs are in the Run state, this function permits the safety output to turn ON and OFF. The Run state is a logical 1 and the Stop state is a logical 0. A virtual ON/OFF input can be added without mapping to a safety output, allowing it to control a non-safety status output. An ON/OFF switch can also be created using a physical input; see [Non-Safety Input Devices](#) on p. 35.

### Virtual Mute Enable

Signals the Safety Controller when the mute sensors are permitted to perform a mute function. When the mute enable function is configured, the mute sensors are not enabled to perform a mute function until the mute enable signal is in the Run state. The enable (Run) state is a logical 1 and the disable (Stop) state is a logical 0. A mute enable switch can also be created using a physical input; see [Non-Safety Input Devices](#) on p. 35.

## 6.7 Safety Outputs

### SCR P

The SCR P-2 has two isolated redundant relay outputs. Each relay output has 3 independent sets of contacts. See [SCR P Specifications](#) on p. 12 for rating and derating considerations.



**WARNING:** Safety Outputs must be connected to the machine control so that the machine's safety-related control system interrupts the circuit to the machine primary control element(s), resulting in a non-hazardous condition.

Do not wire an intermediate device(s), such as a PLC, PES, or PC, that can fail in such a manner that there is the loss of the safety stop command, or that the safety function can be suspended, overridden, or defeated, unless accomplished with the same or greater degree of safety.

The following list describes additional nodes and attributes that can be configured from the Safety Output function block **Properties** window (see [Adding Inputs and Status Outputs](#) on p. 52):

#### EDM (External Device Monitoring)

Enables the Safety Controller to monitor devices under control (FSDs and MPCEs) for proper response to the stopping command of the safety outputs. **It is strongly recommended to incorporate EDM (or AVM)** in the machine design and the Safety Controller configuration to ensure the proper level of safety circuit integrity (see [EDM and FSD Hookup](#) on p. 44).

#### AVM (Adjustable Valve Monitoring)

Enables the Safety Controller to monitor valves or other devices that may become slow, stick, or fail in an energized state or position and whose operation needs to be verified after a Stop signal occurs. Up to three AVM inputs can be selected if EDM is not used. **It is strongly recommended to incorporate AVM (or EDM)** in the machine design and the Safety Controller configuration to ensure the proper level of safety circuit integrity (see [Adjustable Valve Monitoring \(AVM\) Function](#) on p. 33).

#### LR (Latch Reset)

Keeps the SO or RO output Off until the input changes to the Run state and a manual reset operation is performed. See [Manual Reset Input](#) on p. 36 for more information.

#### RE (Reset Enable)

This option appears only if **LR (Latch Reset)** is enabled. The **Latch Reset** can be controlled by selecting **Reset Enable** to restrict when the Safety Output can be reset to a Run condition.

#### FR (Fault Reset)

Provides a manual reset function when input faults occur. The FR node needs to be connected to a Manual Reset button or signal. This function is used to keep the SO or RO output Off until the Input device fault is cleared, the faulted device is in the Run state, and a manual reset operation is performed. This replaces power down/up cycle reset operation. See [Manual Reset Input](#) on p. 36 for more information.

#### Power up mode

The Safety Output can be configured for three power-up scenarios (operational characteristics when power is applied):

- Normal Power-Up Mode (default)
- Manual Power-up Mode
- Automatic Power-Up Mode

See [Manual Reset Input](#) on p. 36 for more information.

### On-Delays and Off-Delays

Each safety output can be configured to function with either an On-Delay or an Off-Delay (see Figure 22 on p.42), where the output turns On or Off only after the time limit has elapsed. An output cannot have both On- and Off-Delays. The On- and Off-Delay time limit options range from 100 milliseconds to 5 minutes, in 1 millisecond increments.

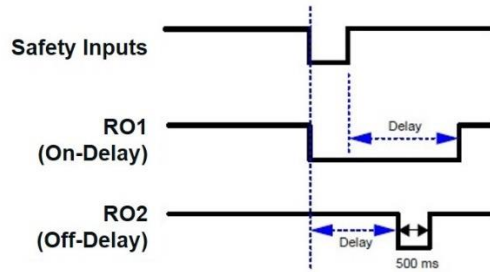

Figure 22: Timing Diagram—General Safety Output On-Delay and Off-Delay



**WARNING:**

- **With a power interruption or loss, an OFF-delay time can end immediately.**
- Failure to follow these instructions could result in serious injury or death.
- The safety output OFF-delay time is honored even if the safety input that caused the OFF-delay timer to start switches back to the Run state before the delay time expires. If such an immediate machine stop condition could cause a potential danger, taken additional safeguarding measures to prevent injuries.

Two Safety Outputs can be linked together when one of the Safety Outputs is configured for an Off-Delay, and the other does not have a delay. After it is linked, the non-delayed output does not immediately turn back on if the controlling input turns on during the Off Delay. To link two Safety Outputs:

1. Open the **Properties** window of the Safety Output that needs to have an Off-Delay.
2. Select "Off-Delay" from the *Safety Output Delay* drop-down list.

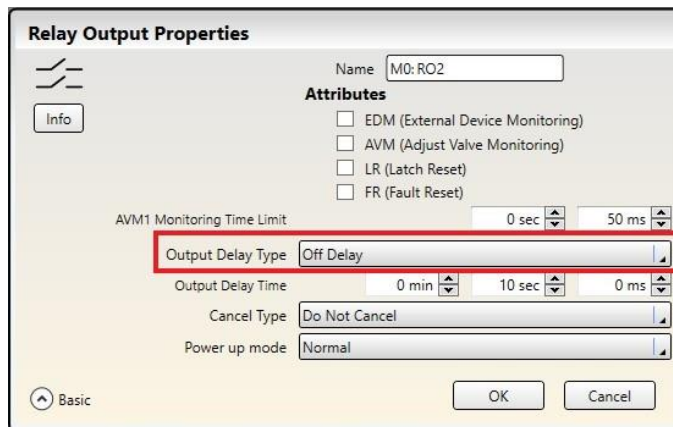

Figure 23: Example Safety Output Delay Selection: Off Delay

3. Set the desired Output Delay time.
4. Click **OK**.
5. Open the **Properties** window of the Safety Output that will link to the Safety Output with an Off-Delay.
6. From *Link to Safety Output* drop-down list, select the Safety Output with an Off-Delay to which you wish to link this Safety Output.

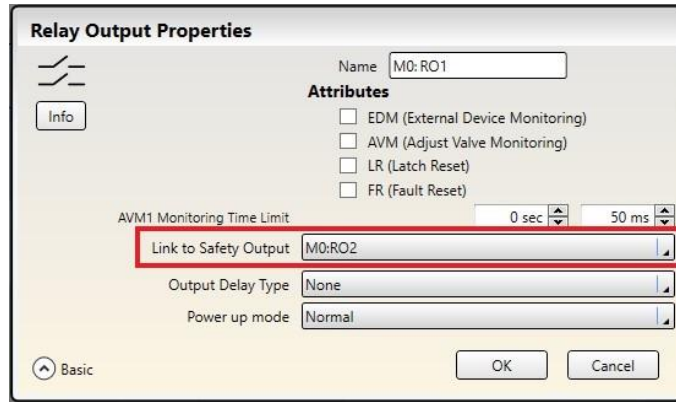

Figure 24: Example Link to Safety Output Selection



**Note:** The same input(s) need to be connected to both Safety Outputs in order for outputs to show up as available for linking.

- Click **OK**. The linked Safety Output will have a link icon indicator.

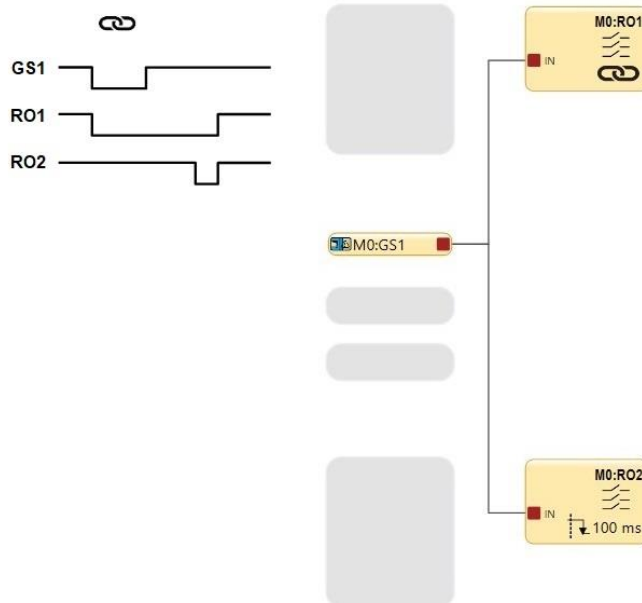

Figure 25: Timing Diagram—Linked Safety Outputs

## 6.7.1 Safety Relay Outputs

The SCR P has isolated redundant relay outputs that can be used to control/switch a wide range of power characteristics (see [SCR P Specifications](#) on p. 12). Unlike a solid-state Safety Output, within an output module an individual safety relay output (Mx:ROx) functions as a group and cannot be split.

The Safety Relay Outputs are controlled and monitored by the SCR P without requiring additional wiring.

For circuits requiring the highest levels of safety and reliability, when used in pairs (two N.O.), either Safety Output must be capable of stopping the motion of the guarded machine in an emergency. When used individually (a single N.O. output), fault exclusion must ensure that failures cannot occur that would result in the loss of the safety function, for example, a short-circuit to another safety output or a secondary source of energy or voltage. For more information, see *Single-channel Control* in [Safety \(Protective\) Stop Circuits](#) on p. 46 and [Fault Exclusion](#) on p. 20.

Whenever possible, incorporating External Device Monitoring (EDM) and/or Adjustable Valve Monitoring (AVM) is highly recommended to monitor devices under control (FSDs and MPCEs) for unsafe failures. See [External Device Monitoring \(EDM\)](#) on p. 44 for more information.

**Output Connections**—The Safety Relay Outputs must be connected to the machine control such that the machine's safety related control system interrupts the circuit or power to the machine primary control element(s) (MPCE), resulting in a non-hazardous condition. When used, Final Switching Devices (FSDs) typically accomplish this when the safety outputs go to the Off state.

The Safety Relay Outputs can be used as the Final Switching Device (FSD) and can be interfaced in either a Dual-Channel or Single-Channel safety (protective) stop circuit (see [FSD Interfacing Connections](#) on p. 46). Refer to [SCR P Specifications](#) on p. 12 before making connections and interfacing the Safety Controller to the machine.

The level of the safety circuit integrity must be determined by risk assessment; this level is dependent on the configuration, proper installation of external circuitry, and the type and installation of the devices under control (FSDs and MPCEs). The safety relay outputs are suitable for Category 4 PL e / SIL 3. See [Figure 26](#) on p. 45 for hookup examples.



**Important:** The user is responsible for supplying overcurrent protection for all relay outputs.

## Overvoltage Category II and III Installations (EN 50178 and IEC 60664-1)

The SCR P is rated for Overvoltage Category III when voltages of 1 V to 150 V ac/dc are applied to the output relay contacts. They are rated for Overvoltage Category II when voltages of 151 V to 250 V ac/dc are applied to the output relay contacts and no additional precautions are taken to attenuate possible overvoltage situations in the supply voltage. The SCR P can be used in an Overvoltage Category III environment (with voltages of 151 V to 250 V ac/dc) if care is taken either to reduce the level of electrical disturbances seen by the SCR P to Overvoltage Category II levels by installing surge suppressor devices (for example, arc suppressors), or to install extra external insulation in order to isolate both the SCR P and the user from the higher voltage levels of a Category III environment.

**For Overvoltage Category III installations with applied voltages from 151 V to 250 V ac/dc applied to the output contact(s):** the SCR P may be used under the conditions of a higher overvoltage category where appropriate overvoltage reduction is provided. Appropriate methods include:

- An overvoltage protective device
- A transformer with isolated windings
- A distribution system with multiple branch circuits (capable of diverting energy of surges)
- A capacitance capable of absorbing energy of surges
- A resistance or similar damping device capable of dissipating the energy of surges

When switching inductive ac loads, it is good practice to protect the SCR P-2 outputs by installing appropriately-sized arc suppressors. However, if arc suppressors are used, they must be installed across the load being switched (for example, across the coils of external safety relays), and never across the SCR P-2 output contacts (see [WARNING, Arc Suppressors](#)).

## 6.7.2 EDM and FSD Hookup

### External Device Monitoring (EDM)

The Safety Controller's safety outputs can control external relays, contactors, or other devices that have a set of normally closed (N.C.), force-guided (mechanically linked) contacts that can be used for monitoring the state of the machine power contacts. The monitoring contacts are normally closed (N.C.) when the device is turned Off. This capability allows the Safety Controller to detect if the devices under load are responding to the safety output, or if the N.O. contacts are possibly welded closed or stuck On.

The EDM function provides a method to monitor these types of faults and to ensure the functional integrity of a dual-

channel system, including the MPCEs and the FSDs.

A single EDM input can be mapped to one or multiple Safety Outputs. This is accomplished by opening the Safety Output **Properties** window and checking **EDM**, then adding **External Device Monitoring** from the **Safety Input** tab in the **Add Equipment** window (accessed from the **Equipment** tab or **Functional View** tab), and connecting the **External Device Monitoring** input to the **EDM** node of the Safety Output.

The EDM inputs can be configured as one-channel or two-channel monitoring. One-channel EDM inputs are used when the OSSD outputs directly control the de-energizing of the MPCEs or external devices.

- **One-Channel Monitoring**—A series connection of closed monitor contacts that are forced-guided (mechanically linked) from each device controlled by the Safety Controller. The monitor contacts must be closed before the Safety Controller outputs can be reset (either manual or automatic). After a reset is executed and the safety outputs turn On, the status of the monitor contacts are no longer monitored and may change state. However, the monitor contacts must be closed within 250 milliseconds of the safety outputs changing from On to Off. See [Figure 26](#) on p. 45.
- **Two-Channel Monitoring**—An independent connection of closed monitor contacts that are forced-guided (mechanically linked) from each device controlled by the Safety Controller. Both EDM inputs must be closed before the Safety Controller can be reset and the OSSDs can turn On. While the OSSDs are On, the inputs may change state (either both open, or both closed). A lockout occurs if the inputs remain in opposite states for more than 250 milliseconds. See [Figure 28](#) on p. 46.
- **No Monitoring (default)**—If no monitoring is desired, do not enable the Safety Output EDM node. If the Safety Controller does not use the EDM function in Category 3 or Category 4 applications, the user must make sure that any single failure or accumulation of failures of the external devices does not result in a hazardous condition and that a successive machine cycle is prevented.



**CAUTION: EDM Configuration**

If the application does not require the EDM function, it is the user's responsibility to ensure that this does not create a hazardous situation.



**CAUTION: External Device Monitoring Connection**

Wire at least one normally closed, forced-guided monitoring contact of each MPCE or external device to monitor the state of the MPCEs (as shown). If this is done, proper operation of the MPCEs will be verified. **Use MPCE monitoring contacts to maintain control reliability.**

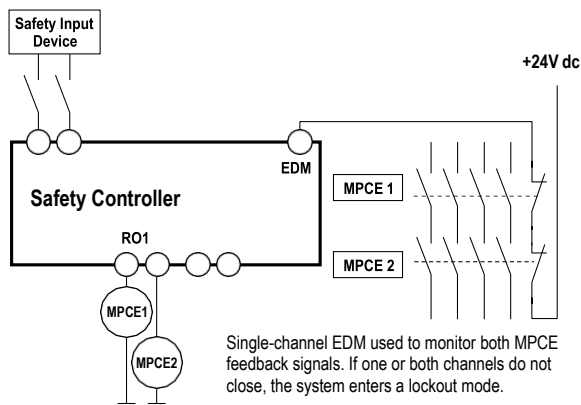

Figure 26: One-channel EDM hookup

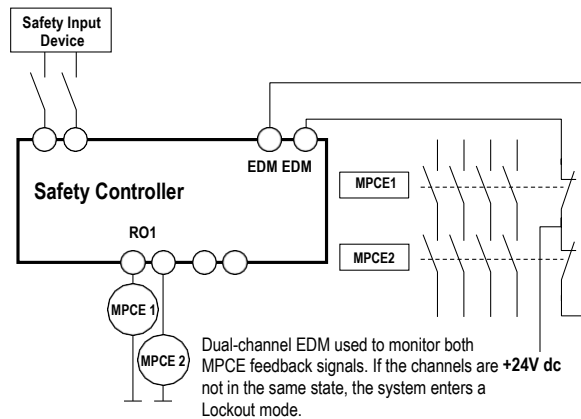
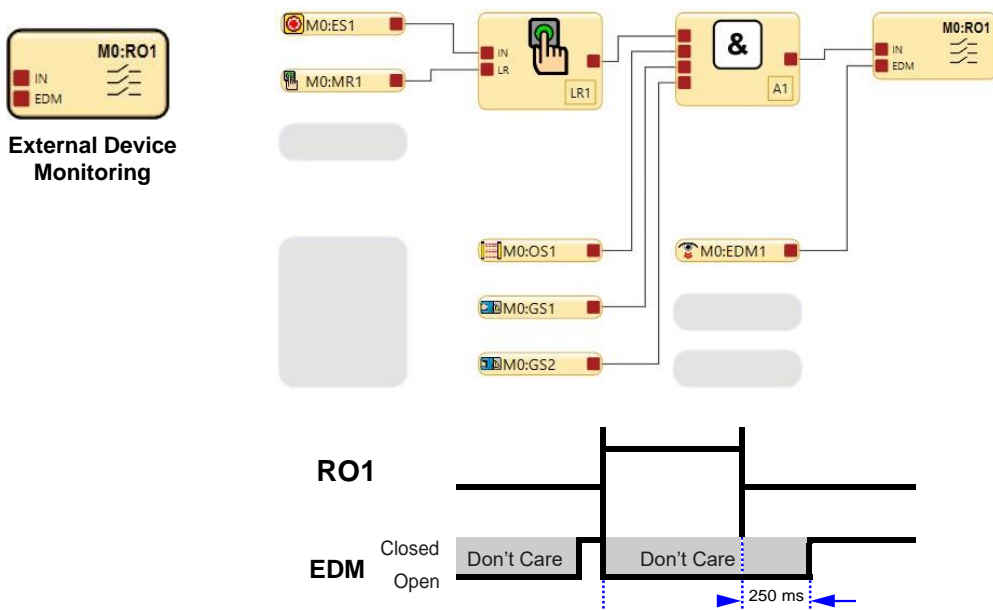

Figure 27: Two-channel EDM hookup



External Device Monitoring EDM is a way to check the operation of dual channel final switching devices or machine primary control elements. The force guided N.C. monitoring contacts of the FSD or MPCE are used as an input to detect a “stuck on” fault condition and will prevent the safety controller outputs from turning On.

Figure 28: Timing logic: One-channel EDM status, with respect to Safety Output

For two-channel EDM, as shown below, both channels must be closed before the Safety Output(s) turn On.

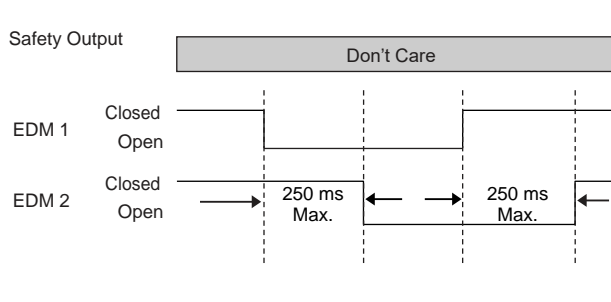

Figure 29: Timing logic: Two-channel EDM, timing between channels

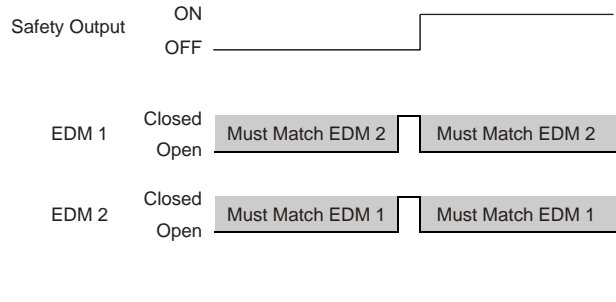

Figure 30: Timing logic: Two-channel EDM status, with respect to Safety Output

## FSD Interfacing Connections

Final switching devices (FSDs) interrupt the power in the circuit to the Machine Primary Control Element (MPCE) when the Safety Outputs go to the Off-state. FSDs can take many forms, though the most common are forced-guided (mechanically linked) relays or Interfacing Modules. The mechanical linkage between the contacts allows the device to be monitored by the external device monitoring circuit for certain failures.

Depending on the application, the use of FSDs can facilitate controlling voltage and current that differs from the Safety Outputs of the Safety Controller. FSDs may also be used to control an additional number of hazards by creating multiple safety stop circuits.

## Safety (Protective) Stop Circuits

A safety stop allows for an orderly cessation of motion or hazardous situation for safeguarding purposes, which results in a stop of motion and removal of power from the MPCEs (assuming this does not create additional hazards). A safety stop circuit typically comprises a minimum of two normally open contacts from forced-guided (mechanically linked) relays, which are monitored (via a mechanically linked NC contact) to detect certain failures so that the loss of the safety function does not occur. Such a circuit can be described as a “safe switching point.”

Typically, safety stop circuits are a series connection of at least two N.O. contacts coming from two separate, positive-guided relays, each controlled by one separate safety output of the Safety Controller. The safety function relies on the use of redundant contacts to control a single hazard, so that if one contact fails On, the second contact stops the hazard and prevents the next cycle from occurring.

Interfacing safety stop circuits must be wired so that the safety function cannot be suspended, overridden, or defeated, unless accomplished in a manner at the same or greater degree of safety as the machine's safety-related control system that includes the Safety Controller.

The normally open outputs from an interfacing module are a series connection of redundant contacts that form safety stop circuits and can be used in either single-channel or dual-channel control methods.

**Dual-Channel Control**—Dual-channel (or two-channel) control has the ability to electrically extend the safe switching point beyond the FSD contacts. With proper monitoring, such as EDM, this method of interfacing is capable of detecting certain failures in the control wiring between the safety stop circuit and the MPCEs. These failures include a short-circuit of one channel to a secondary source of energy or voltage, or the loss of the switching action of one of the FSD outputs, which may lead to the loss of redundancy or a complete loss of safety if not detected and corrected.

The possibility of a wiring failure increases as the physical distance between the FSD safety stop circuits and the MPCEs increase, as the length or the routing of the interconnecting wires increases, or if the FSD safety stop circuits and the MPCEs are located in different enclosures. Thus, dual-channel control with EDM monitoring should be used in any installation where the FSDs are located remotely from the MPCEs.

**Single-Channel Control**—Single-channel (or one-channel) control uses a series connection of FSD contacts to form a safe switching point. After this point in the machine's safety-related control system, failures that would result in the loss of the safety function can occur, for example, a short-circuit to a secondary source of energy or voltage.

Thus, this method of interfacing should be used only in installations where FSD safety stop circuits and the MPCEs are physically located within the same control panel, adjacent to each other, and are directly connected to each other; or where the possibility of such a failure can be excluded. If this cannot be achieved, then two-channel control should be used.

Methods to exclude the possibility of these failures include, but are not limited to:

- Physically separating interconnecting control wires from each other and from secondary sources of power
- Routing interconnecting control wires in separate conduit, runs, or channels
- Routing interconnecting control wires with low voltage or neutral that cannot result in energizing the hazard
- Locating all elements (modules, switches, devices under control, etc.) within the same control panel, adjacent to each other, and directly connected with short wires
- Properly installing multi-conductor cabling and multiple wires that pass through strain-relief fittings. Over-tightening of a strain-relief can cause short circuits at that point
- Using positive-opening or direct-drive components installed and mounted in a positive mode



**WARNING:**

- **Properly install arc or transient suppressors**
- Failure to follow these instructions could result in serious injury or death.
- Install any suppressors as shown across the coils of the FSDs or MPCEs. Do not install suppressors directly across the contacts of the FSDs or MPCEs. In such a configuration, it is possible for suppressors to fail as a short circuit.



**WARNING: Safety Output Interfacing**

To ensure proper operation, the BERNSTEIN product output parameters and machine input parameters must be considered when interfacing the solid state safety outputs to the machine inputs. Machine control circuitry must be designed so that:

- The maximum cable resistance value between the Safety Controller solid-state safety outputs and the machine inputs is not exceeded
- The Safety Controller's solid-state safety output maximum Off state voltage does not result in an On condition
- The Safety Controller's solid-state safety output maximum leakage current, due to the loss of 0 V, does not result in an On condition

**Failure to properly interface the safety outputs to the guarded machine may result in serious bodily injury or death.**



**WARNING: Shock Hazard and Hazardous Energy**

**Always disconnect power from the safety system (for example, device, module, interfacing, etc.) and the machine being controlled before making any connections or replacing any component.**

Electrical installation and wiring must be made by Qualified Personnel<sup>7</sup> and must comply with the relevant electrical standards and wiring codes, such as the NEC (National Electrical Code), ANSI NFPA79, or IEC/EN 60204-1, and all applicable local standards and codes.

**Lockout/tagout procedures may be required.** Refer to OSHA 29CFR1910.147, ANSI Z244-1, ISO 14118, or the appropriate standard for controlling hazardous energy.

<sup>7</sup> A person who, by possession of a recognized degree or certificate of professional training, or who, by extensive knowledge, training and experience, has successfully demonstrated the ability to solve problems relating to the subject matter and work.





**WARNING:**

- **Properly Wire the Device**
- Failure to properly wire the Safety Controller to any particular machine could result in a dangerous condition that could result in serious injury or death.
- The user is responsible for properly wiring the Safety Controller. The generalized wiring configurations are provided only to illustrate the importance of proper installation.

**Generic SCR P Hookup: Safety Output with EDM**

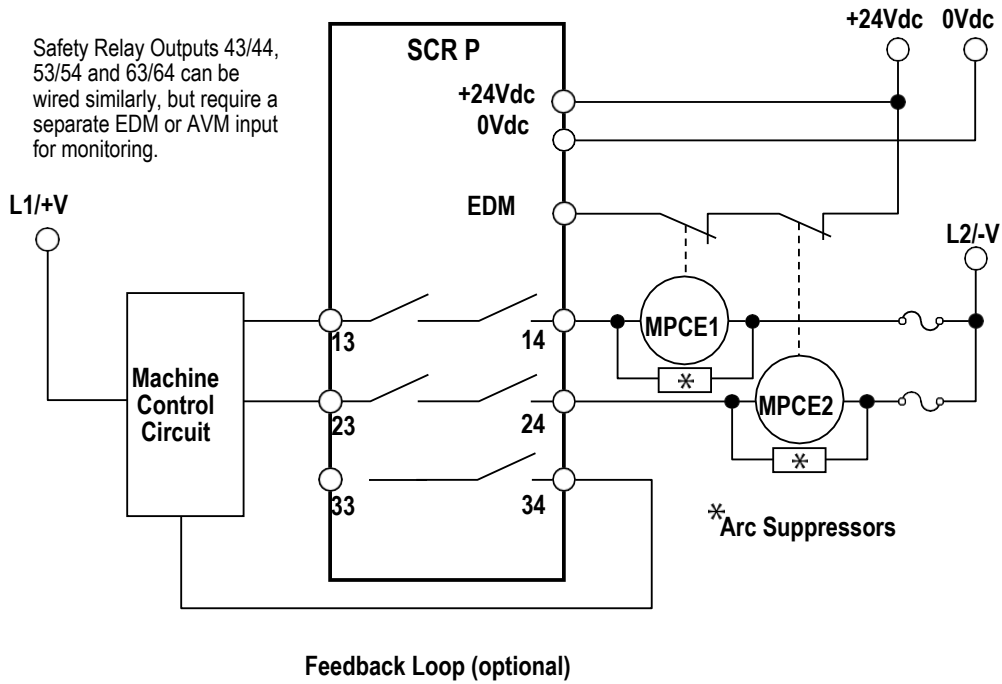

Figure 31: Generic SCR P Hookup: Safety Relay Output (Dual-Channel) with EDM

## 6.8 Status Outputs

### 6.8.1 Status Output Signal Conventions

 **Note:** You cannot use the safety outputs as status outputs in the SCR P.

There are two signal conventions selectable for each status output: "PNP On" (sourcing 24 V dc), or "PNP Off" (non-conducting). The default convention is Active = PNP On.

Table 1: Status Output Signal Conventions

Function	Signal Conventions			
	Active = PNP On		Active = PNP Off	
	Status Output State		Status Output State	
	+24 V dc	Off	Off	24 V dc
<b>Bypass</b>	Bypassed	Not Bypassed	Bypassed	Not Bypassed
<b>Mute</b>	Muted	Not Muted	Muted	Not Muted
<b>Output Delay In Progress</b>	Delay	No Delay	Delay	No Delay
<b>Track Input</b>	Run	Stop	Run	Stop
<b>Track Input Fault</b>	Fault	Ok	Fault	Ok
<b>Track Any Input Fault</b>	Fault	Ok	Fault	Ok
<b>Track Input Group</b>	Initiated Stop	Other Input Caused Stop	Initiated Stop	Other Input Caused Stop
<b>Track Output</b>	SO On	SO Off	SO On	SO Off
<b>Track Output Fault</b>	Fault	Ok	Fault	Ok
<b>Track Output Fault All</b>	Fault	Ok	Fault	Ok
<b>Track Output Logical State</b>	Logically On	Logically Off	Logically On	Logically Off
<b>Track Function Block State</b>	Run	Stop	Run	Stop
<b>Waiting for Manual Reset</b>	Reset Needed	Not Satisfied	Reset Needed	Not Satisfied
<b>System Lockout</b>	Lockout	Run Mode	Lockout	Run Mode

### 6.8.2 Status Output Functionality

**SCR P:** Up to four convertible inputs may be used as a Status Output.

Status Outputs can be configured to perform the following functions:

#### **Bypass**

Indicates when a particular Safety Input is bypassed.

#### **Mute**

Indicates a muting active status for a particular mutable Safety Input:

- On when a mutable input is muted
- Off when a mutable input is not muted
- Flashing when the conditions to start a mute-dependent override exist (an inactive muting cycle, the mutable Safety Input is in the stop state, and at least one muting sensor is in the stop (blocked) state); not available for Virtual Status Output
- On during an active mute-dependent override function (not a bypass function) of a mutable Safety Input

#### **Output Delay In Progress**

Indicates if either On- or Off-Delay is active.

**Track Input**

Indicates the state of a particular Safety Input.

**Track Input Fault**

Indicates when a particular Safety Input has a fault.

**Track Any Input Fault**

Indicates when any Safety Input has a fault.

**Track Input Group**

Indicates the state of a group of Safety Inputs, for example, which Safety Input turned off first. Once this function has been indicated, the function may be re-enabled by a configured Reset Input. Up to three Input Groups can be tracked.

**Track Output**

Indicates the physical state of a particular Safety Output (On or Off).

**Track Output Fault**

Indicates when a particular Safety Output has a fault.

**Track Output Fault All**

Indicates a fault from any Safety Output.

**Track Output Logical State**

Indicates the logical state of a particular Safety Output. For example, the logical state is Off but the Safety Output is in an Off-Delay and not physically off yet.

**Track Function Block State**

Indicates the state of a particular Function Block.

**Waiting for Manual Reset**

Indicates a particular configured reset is needed.

**System Lockout**

Indicates a Non-Operating Lockout Condition, for example unmapped input connected to 24 V.

## 6.9 Virtual Status Outputs

---

Up to 64 Virtual Status Outputs can be added for any configuration using Modbus/TCP, EtherNet/IP Input Assemblies, EtherNet/IP Explicit Messages, and PCCC protocols and up to 256 Virtual Status Outputs can be added on SCR P Safety Controllers. SCR P Safety Controllers can also use PROFINET. These outputs can communicate the same information as the Status Outputs over the network. See [Status Output Functionality](#) on p. 50 for more information. The **Auto Configure** function, located on the **Industrial Ethernet** tab of the Software, automatically configures the Virtual Status Outputs to a set of commonly used functions, based on the current configuration. This function is best used after the configuration has been determined. Virtual Status Output configuration can be manually revised after the **Auto Configure** function has been used. The information available over the network is consistent with the logical state of the inputs and outputs within 100 ms for the Virtual Status Output tables (viewable via the Software) and within 1 second for the other tables. The logical state of inputs and outputs is determined after all internal debounce and testing is complete. See [Industrial Ethernet Tab](#) on p. 92 for details on configuring Virtual Status Outputs.

DCD chains and individual device performance and status can be obtained from SCR P Safety Controllers. Sixteen (16 bit) words can be obtained about the status of each chain. Three (16 bit) administrative words and 18 bytes (8 bits each) of specific data on an individual device of a chain can be obtained. See [Assembly Objects](#) on p. 111 for more details.

# 7 Getting Started

Power up the Safety Controller and verify that the power LED is ON green.

## 7.1 Creating a Configuration

---

The following steps are required to complete and confirm (write to controller) the configuration:

1. Define the safeguarding application (risk assessment).
  - Determine the required devices
  - Determine the required level of safety
2. Install the BERNSTEIN Safety Controller software. See [Installing the Software](#) on p. 16.
3. Become familiar with the Software options. See [Software Overview](#) on p. 61.
4. Start the Software.
5. Start a new project by clicking **New Project/Recent Files**.
6. Define the **Project Settings**. See [Project Settings](#) on p. 63.
7. Design the control logic. See [Designing the Control Logic](#) on p. 56.
8. Set optional Safety Output On- or Off-time delays.
9. If used, configure the network settings. See [Network Settings: Modbus/TCP, Ethernet/IP, PCCC](#) on p. 93 or [Network Settings: PROFINET](#) on p. 94.
10. Save and confirm the configuration. See [Saving and Confirming a Configuration](#) on p. 56.

The following steps are optional and may be used to aid with the system installation:

- Modify the configuration access rights. See [SCR P Password Manager](#) on p. 99.
- View the **Configuration Summary** tab for the detailed device information and response times. See [Configuration Summary Tab](#) on p. 97.
- Print the configuration views, including the **Configuration Summary** and **Network Settings**. See [Print Options](#) on p. 98.
- Test the configuration using Simulation Mode. See [Simulation Mode](#) on p. 104.

## 7.2 Adding Inputs and Status Outputs

---

Safety and Non-Safety Inputs can be added from either the **Equipment** tab or the **Functional View** tab. Status Outputs can be added from the **Equipment** tab only. When inputs are added on the **Equipment** tab, they are automatically placed in the **Functional View** tab. All inputs and **Logic** and **Function Blocks** can be moved around on the **Functional View** tab. The **Safety Outputs** are statically positioned on the right side.

### 7.2.1 Adding Safety and Non-Safety Inputs

1. On the **Equipment** tab, click  below the module which will have the input device connected (the module and terminals can be changed from the input device **Properties** window) or any of the placeholders on the **Functional View** tab.



**Note:** Virtual Non-Safety Inputs are available only from the **Functional View** tab.

2. Click **Safety Input** or **Non-Safety Input** to add input devices:

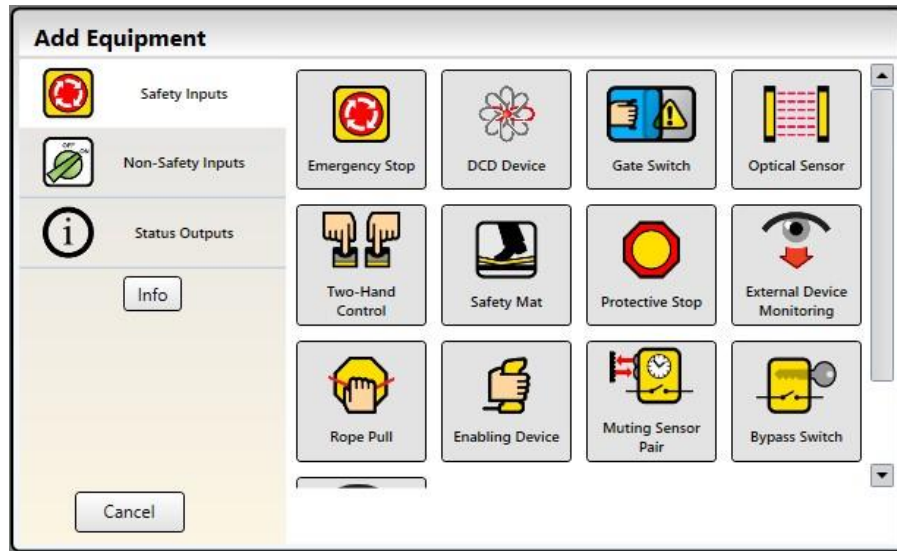

Figure 32: Safety Inputs (Virtual Non-Safety Inputs available only from the **Functional View Tab**):

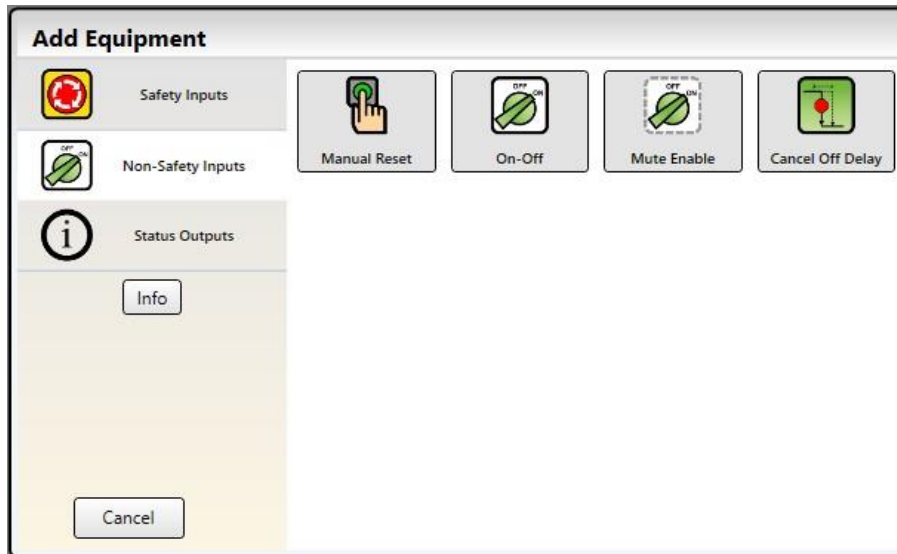

Figure 33: Non-Safety Inputs (Virtual Non-Safety Inputs available only from the **Functional View Tab**)

3. Select appropriate device settings:

**Basic settings:**

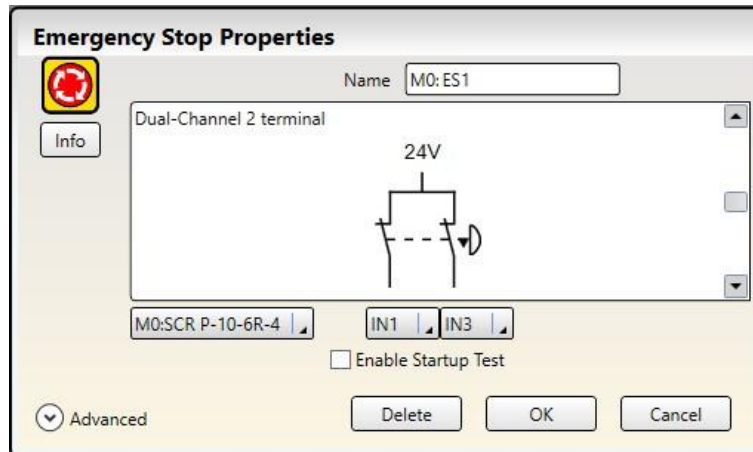

Figure 34: Basic Safety Input Settings

- *Name*—input device name; generated automatically and can be changed by the user
- *Circuit Type*—the circuit and signal convention options appropriate for the selected input device
- *Module*—the module to which the input device is connected
- *I/O Terminals*—the assignment of input terminals for the selected device on the selected module
- *Enable Startup Test* (where applicable)—an optional precautionary safety input device test required after each power-up
- *Reset Options* (where applicable)—various reset options such as Manual Power Up, System Reset, and Reset Track Input Group

**Advanced settings (where applicable):**

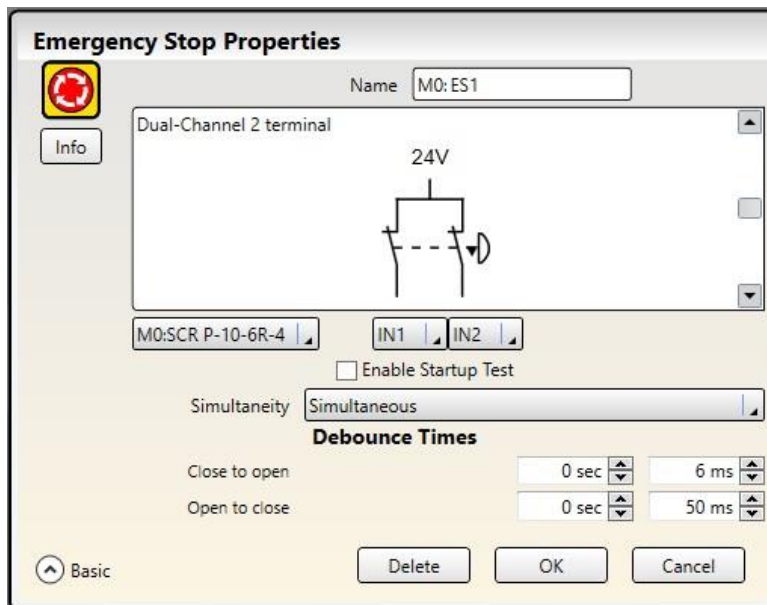

Figure 35: Advanced Safety Input Settings

- *Simultaneity* (where applicable)—Simultaneous or Concurrent (see [Glossary](#) on p. 194 for definitions)
- *Debounce Times*—the signal state transition time
- *Monitored/Non-Monitored* (where applicable)

**DCD Device Properties (where applicable):**

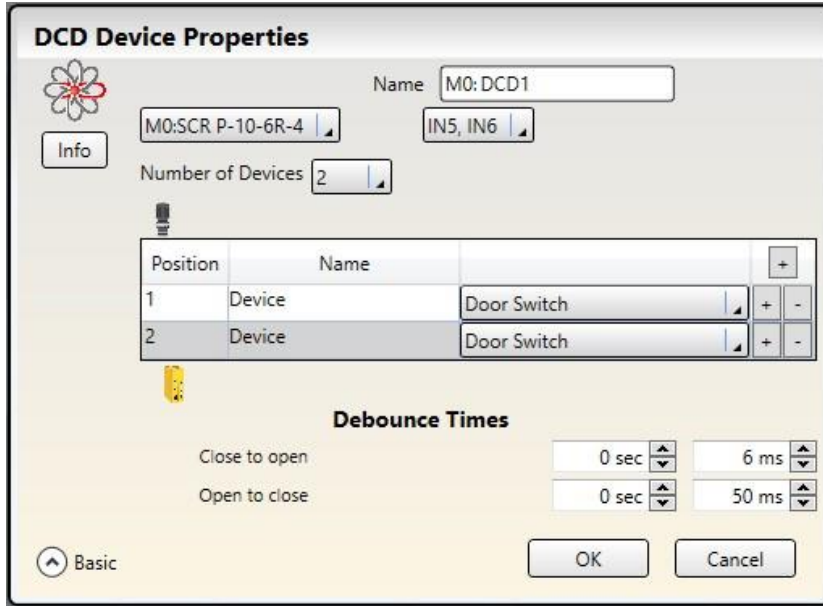

Figure 36: Advanced DCD Device Settings

- *Name*—input device name; generated automatically and can be changed by the user
- *I/O Terminals*—the assignment of input terminals for the selected device on the selected module
- *Number of Devices* (required)—the number of DCD sensors used in the application
- *Position, Name, and Type*—the position, name, and type (Door Switch) of DCD sensors used in the application
- *Debounce Times*—the signal state transition time

**Note:** If the entire chain consists of only door switches, the configuration rules for a gate switch apply.

### 7.2.2 Adding Status Outputs

1. On the **Equipment** tab, click below the module which will have the status monitoring.

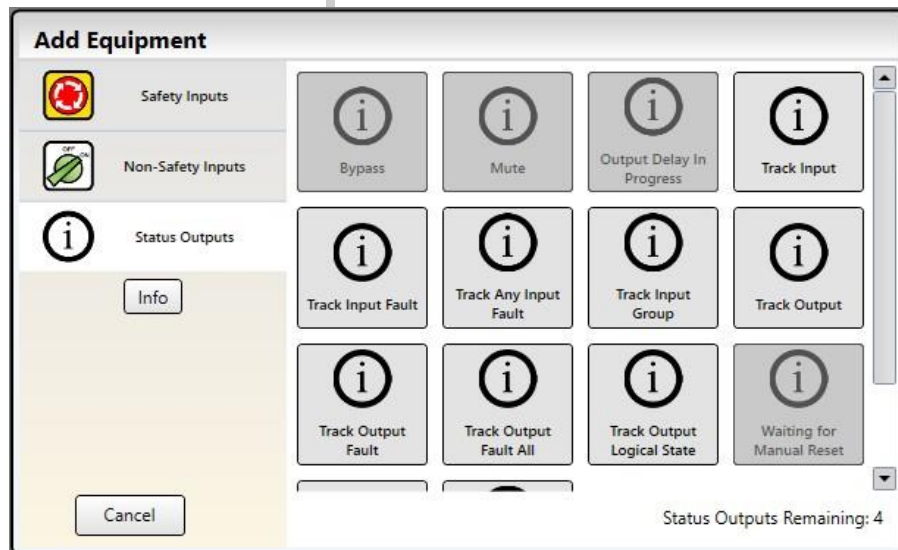

Figure 37: Status Outputs

2. Click **Status Outputs** to add status monitoring<sup>8</sup>.

<sup>8</sup> Status outputs can be configured when the state of an input device or an output needs to be communicated. The IOx terminals are used for these status signals.

3. Select appropriate Status Output settings:

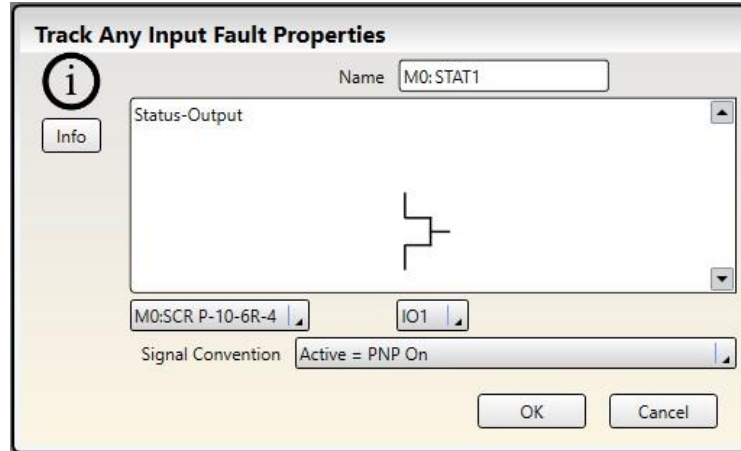



Figure 38: Status Output Properties

- Name
- Module
- I/O (where applicable)
- Terminal
- Input or Output (where applicable)
- Signal Convention

## 7.3 Designing the Control Logic

To design the control logic:

1. Add the desired **Safety** and **Non-Safety Inputs**:
  - On the **Equipment** tab: click  under the module to which the input will be connected (the module can be changed in the input **Properties** window)
  - On the **Functional View** tab: click any of the empty placeholders in the left column

See [Adding Inputs and Status Outputs](#) on p. 52 for more information and device properties.

2. Add **Logic** and/or **Function Blocks** (see [Logic Blocks](#) on p. 66 and [Function Blocks](#) on p. 68) by clicking any of the empty placeholders in the middle area.



**Note:** The response time of the Safety Outputs can increase if a large number of blocks are added to the configuration. Use the function and logic blocks efficiently to achieve the optimum response time.

3. Create the appropriate connections between added inputs, **Function** and **Logic Blocks**, and Safety Outputs.



**Note:** The **Check List** on the left displays connections that are required for a valid configuration and all items must be completed. The Safety Controller will not accept an invalid configuration.



**Tip:** To aid with creating a valid configuration, the program displays helpful tooltips if you attempt to make an invalid connection.

## 7.4 Saving and Confirming a Configuration

Confirmation is a verification process where the Safety Controller analyzes the configuration generated by the Software for logical integrity and completeness. The user must review and approve the results before the configuration can be saved and used by the Safety Controller. Once confirmed, the configuration can be sent to a Safety Controller or saved on a PC or an SCR P-FPS drive.



**WARNING:**

- Complete the Commissioning Checkout Procedure
- Failure to follow the commissioning process may lead to serious injury or death.
- After confirming the configuration, the Safety Controller operation must be fully tested (commissioned) before it can be used to control any hazards.

**Saving a Configuration:**

1. Click  **Save Project**.
2. Select **Save As**.
3. Navigate to the folder where you wish to save the configuration.
4. Name the file (may be the same or different from the configuration name).
5. Click **Save**.

**Confirming a Configuration** (the Safety Controller must be powered up and connected to the PC via the USB cable):

1. Click .
2. Click **Write Configuration to Controller**.
3. If prompted, enter the password (default password is 1901).  
The **Entering config-mode** screen opens.
4. Click **Continue** to enter the configuration mode.  
After the **Reading Configuration from the Controller** process is completed, the **Confirm Configuration** screen opens.
5. Verify that the configuration is correct.
6. **Scroll to the end of the configuration and click Confirm.**
7. After the **Writing Configuration To Controller** process is completed, click **Close**.

**Note:**

- Network settings are sent separately from the configuration settings. Click **Send** from the **Network Settings** window to write the network settings to the Safety Controller.
- SCR P: Network settings are automatically sent only if the SCR P is a factory default Safety Controller. Otherwise, use the **Network Settings** window.
- SCR P: Passwords are automatically written only if the SCR P is a factory default Safety Controller or the configuration is confirmed. In any other case, use the **Password Manager** window to write passwords to an SCR P.

If you are configuring an SCR P, the **Do you want to change the passwords of the controller?** screen may display.

8. SCR P: If prompted and if desired, change the SCR P passwords.
9. Cycle power or perform a System Reset for the changes to take effect in the Safety Controller.
10. Save the confirmed configuration on the PC.



**Note:** Saving the now confirmed configuration is recommended. Confirmed configurations are a different file format (.xcc) than an unconfirmed file (.xsc). Confirmed configurations are required for loading into an SCR P-FPS drive. Click **Save As** to save.

## 7.4.1 Notes on Confirming or Writing a Configuration to a Configured SCR P

User settings and passwords affect how the system responds when confirming a configuration or writing a confirmed configuration to a configured SCR P Safety Controller.

**User1**

1. Click **Write configuration to Controller** to confirm a configuration (or write a confirmed configuration) to a configured Safety Controller.
2. Enter the User1 password.
3. The confirmation (or writing) process begins.

At the end of the confirmation (or writing) process, the Safety Controller will have received:

- New passwords
- New configuration Network settings are not changed.

## User2 or User3—Successful Configuration Confirmation or Writing

This scenario assumes the following settings for User2 or User3:

- **Allowed to change the configuration** = enabled
  - **Allowed to change the network settings** = enabled OR disabled
1. Click **Write configuration to Controller** to confirm a configuration (or write a confirmed configuration) to a configured Safety Controller.
  2. Enter the User2 or User3 password.
  3. The confirmation (or writing) process begins.

At the end of the confirmation (or writing) process, the Safety Controller will have received:

- New configuration

Passwords and Network settings are not changed.

## User2 or User3—Unsuccessful Configuration Confirmation or Writing

This scenario assumes the following settings for User2 or User3:

- **Allowed to change the configuration** = disabled
  - **Allowed to change the network settings** = enabled OR disabled
1. Click **Write configuration to Controller** to confirm a configuration (or write a confirmed configuration) to a configured Safety Controller.
  2. Enter the User2 or User3 password.
  3. The confirmation (or writing) process is aborted.

## 7.5 Sample Configurations

---

The Software provides several sample configurations that demonstrate various features or applications of the Safety Controller. To access these configurations, go to  **Open Project > Sample Projects** and select the desired project.

The SCR P has eight sample configurations. These samples include typical applications of the SCR P model. Use the samples as a starting point and modify them for your specific needs.

## 8 Software

The BERNSTEIN Safety Controller Software is an application with real-time display and diagnostic tools that are used to:

- Design and edit configurations
- Test a configuration in Simulation Mode
- Write a configuration to the Safety Controller
- Read the current configuration from the Safety Controller
- Display the real-time information, such as device statuses
- Display the fault information

The Software uses icons and circuit symbols to assist in making appropriate input device and property selections. As the various device properties and I/O control relationships are established on the **Functional View** tab, the program automatically builds the corresponding wiring and ladder logic diagrams.

See [Creating a Configuration](#) on p. 52 for the configuration design process. See [Sample Configuration](#) on p. 58 for a sample configuration design process.

See [Wiring Diagram Tab](#) on p. 87 to connect the devices, and [Ladder Logic Tab](#) on p. 88 for the ladder logic rendering of the configuration.

See [Live Mode](#) on p. 101 for the Safety Controller Run-time information.

### 8.1 Abbreviations

Abbreviation	Description
<b>AVM</b>	Adjustable Valve Monitoring input node of the Safety Outputs
<b>AVMx</b>	Adjustable Valve Monitoring input
<b>BP</b>	Bypass input node of the Bypass Blocks and Muting Blocks
<b>BPx</b>	Bypass Switch input
<b>CD</b>	Cancel Delay input node of the Safety Outputs
<b>CDx</b>	Cancel Delay input
<b>DCD</b>	In-Series Diagnostic
<b>ED</b>	Enabling Device input node of the Enabling Device Blocks
<b>EDx</b>	Enabling Device input
<b>EDM</b>	External Device Monitoring input node of the Safety Outputs
<b>EDMx</b>	External Device Monitoring input
<b>ES</b>	Emergency Stop input node of the Enabling Device Blocks
<b>ESx</b>	Emergency Stop input
<b>ETB</b>	External Terminal Block (SCR P-2 only)
<b>FID</b>	Feature identification
<b>FR</b>	Fault Reset input node of the Safety Outputs
<b>GSx</b>	Gate Switch input
<b>JOG</b>	Jog Input node of the Enabling Device Blocks
<b>IN</b>	Normal Input node of function blocks and Safety Output blocks
<b>LR</b>	Latch Reset input node of the Latch Reset Block and the Safety Outputs
<b>ME</b>	Mute Enable input node of the Muting Blocks and Two-Hand Control Blocks
<b>MEx</b>	Mute Enable input
<b>MP1</b>	First Muting Sensor Pair input node in Muting Blocks and Two-Hand Control Blocks
<b>MP2</b>	Second Muting Sensor Pair input node (Muting Blocks only)
<b>Mx</b>	Base Controller and Expansion modules (in the order displayed on the <b>Equipment</b> tab)

<sup>9</sup> The "x" suffix denotes the automatically assigned number.

Abbreviation	Description
<b>MRx</b>	Manual Reset input
<b>MSPx</b>	Muting Sensor Pair input
<b>ONx</b>	On-Off input
<b>OSx</b>	Optical Sensor input
<b>PSx</b>	Protective Stop input
<b>RE</b>	Reset Enable input node of the Latch Reset Blocks and the Safety Outputs
<b>ROx</b>	Relay Output
<b>RPI</b>	Requested Packet Interval
<b>RPx</b>	Rope Pull input
<b>RST</b>	Reset node of the SR-Flip-Flop, RS-Flip-Flop, Latch Reset Blocks, and Enabling Device Blocks
<b>SET</b>	Set node of the SR- and RS-Flip-Flop Blocks
<b>SMx</b>	Safety Mat input
<b>SOx</b>	Safety Output
<b>STATx</b>	Status Output
<b>TC</b>	Two-Hand Control input node of the Two-Hand Control Blocks
<b>TCx</b>	Two-Hand Control input

<sup>9</sup> The "x" suffix denotes the automatically assigned number.

## 8.2 Software Overview

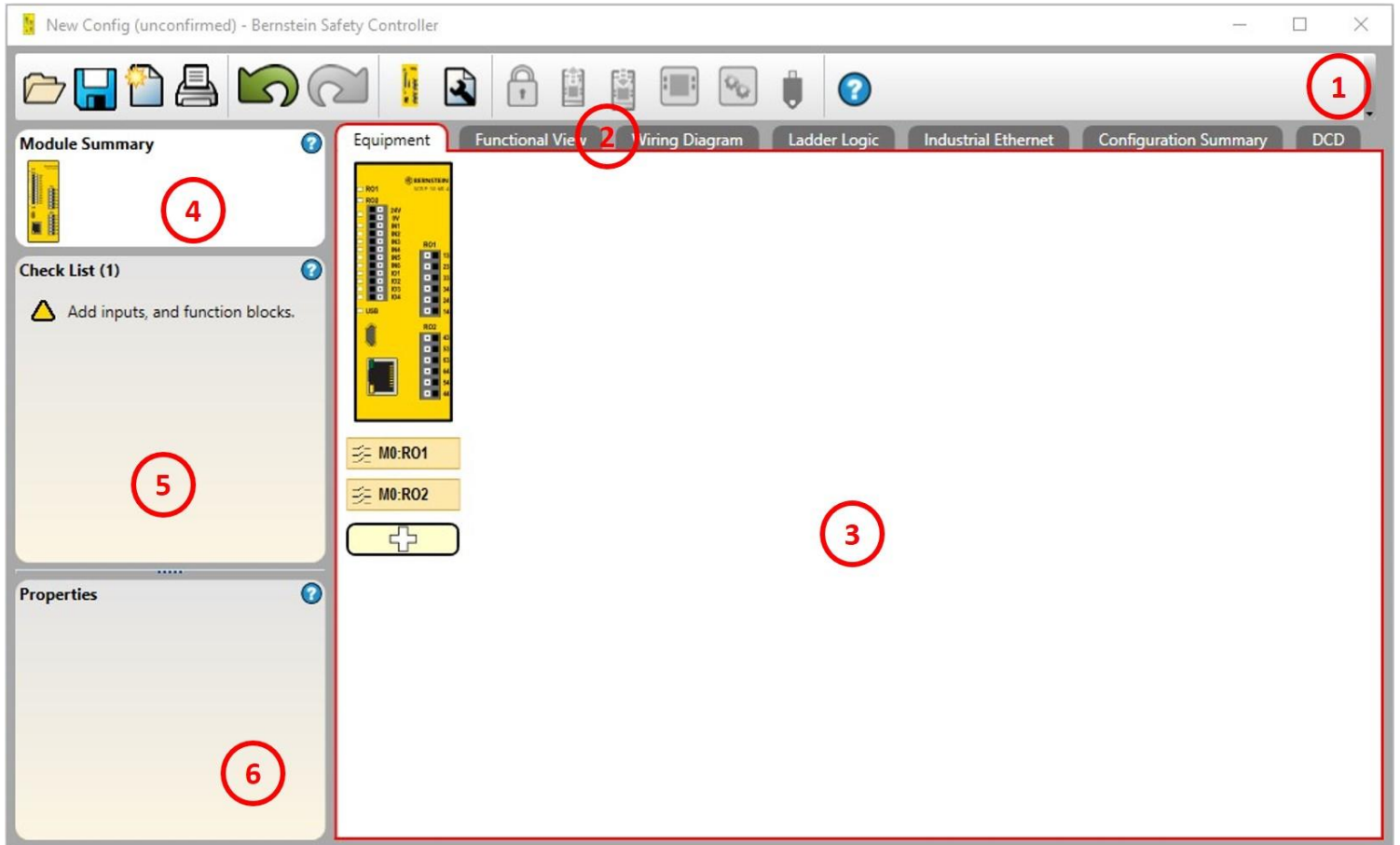

















Figure 39: BERNSTEIN Safety Controller Software

## (1) Navigation Toolbar

- |   |   |   |  |
|---|---|---|--|
|  | Starts a <b>New project</b>   |  | Reads the data, such as Fault Log, Configuration, Network Settings, and Device Information from the Safety Controller  |
|  | Opens an existing project, opens a <b>Recent</b> project, or opens <b>Sample Projects</b> |  | Writes the data, such as Configuration Settings to the Safety Controller   |
|  | Saves (or Save As) the project to the user-defined location                               |  | Makes the Live Mode view available   |
|  | Prints a customizable Configuration Summary   |  | Makes the Simulation Mode view available   |
|  | Reverts up to ten previous actions  |  | Indicates SCR P-PA or SCR P-FPS drive connection   |
|  | Re-applies up to ten previously reverted actions  |   | Opens the <b>Help</b> options <ul style="list-style-type: none"> <li>• <b>Help</b>—Opens Help topics</li> <li>• <b>About</b>—Displays Software version number and user responsibilities warning</li> <li>• <b>Release Notes</b>—Displays the release notes for each version of the software</li> <li>• <b>Icons</b>—Switches between US- and European- style icons</li> <li>• <b>Support Information</b>—Describes how to request help from the BERNSTEIN Advanced Technical Support Group</li> <li>• <b>Language</b>—Selects the Software language options</li> </ul> |
|  | Displays Network Settings and writes the Network Settings to the Safety Controller        |   |  |
|  | Displays Project Settings   |  |  |
|  | Opens Password Manager  |   |  |

## (2) Tabs for Worksheets and Diagrams

**Equipment**—Displays an editable view of all connected equipment

**Functional View**—Provides editable iconic representation of the control logic

**Wiring Diagram**—Displays the I/O device wiring detail for the use by the installer

**Ladder Logic**—Displays a symbolic representation of the Safety Controller's safeguarding logic for the use by the machine designer or controls engineer

**Industrial Ethernet** (when enabled) —Displays editable network configuration options

**Configuration Summary**—Displays a detailed configuration summary

**Live Mode** (when enabled)—Displays the live mode data, including current faults

**Simulation Mode** (when enabled)—Displays the simulation mode data

**DCD**—Displays the DCD chain

## (3) Selected View

Displays the view corresponding to the selected tab (**Equipment** view shown)

## (4) Module Summary

Displays the Base Controller and any connected modules or displays the SCR P

## (5) Check List

Provides action items to configure the system and correct any errors to successfully complete the configuration

## (6) Properties

Displays the properties of the selected device, function block, or connection (properties cannot be edited in this view; click **Edit** below to make changes)

**Delete**—Deletes the selected item

**Edit**—Displays the configuration options for the selected device or function block

See [Software: Troubleshooting](#) on p. 184 for issues related to the Software functionality.

## 8.3 Project Settings

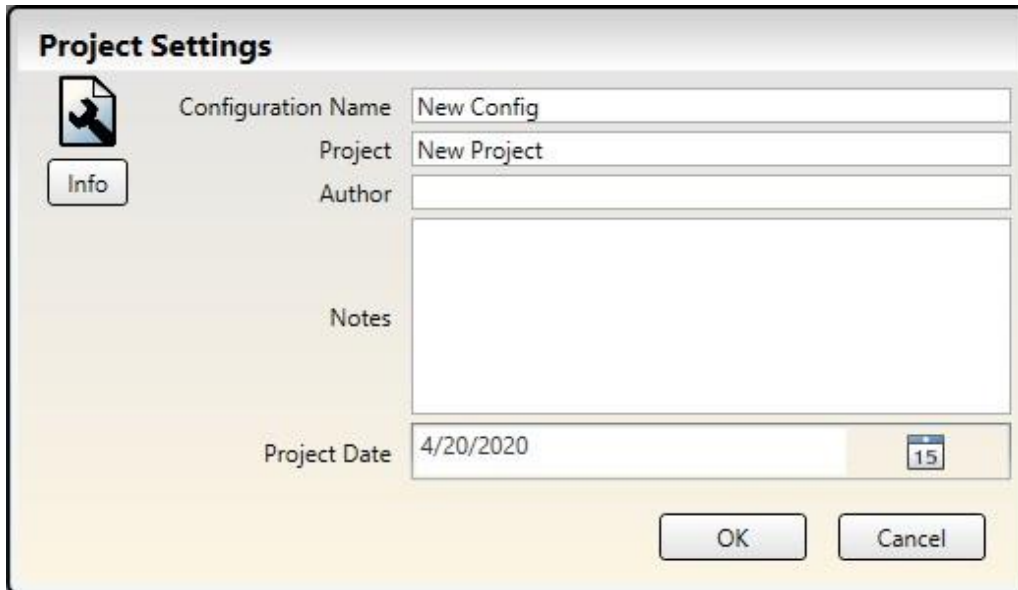

**Project Settings**

 Configuration Name

Project

Author

Notes

Project Date  

Figure 40: Project Settings

Each configuration has an option to include additional project information for easier differentiation between multiple configurations. To enter this information, click **Project Settings**.

### **Configuration Name**

Name of the configuration; different from file name.

### **Project**

Project name; useful for distinguishing between various application areas.

### **Author**

Person designing the configuration.

### **Notes**

Supplemental information for this configuration or project.

### **Project Date**

Date pertaining to the project.

## 8.4 Equipment Tab

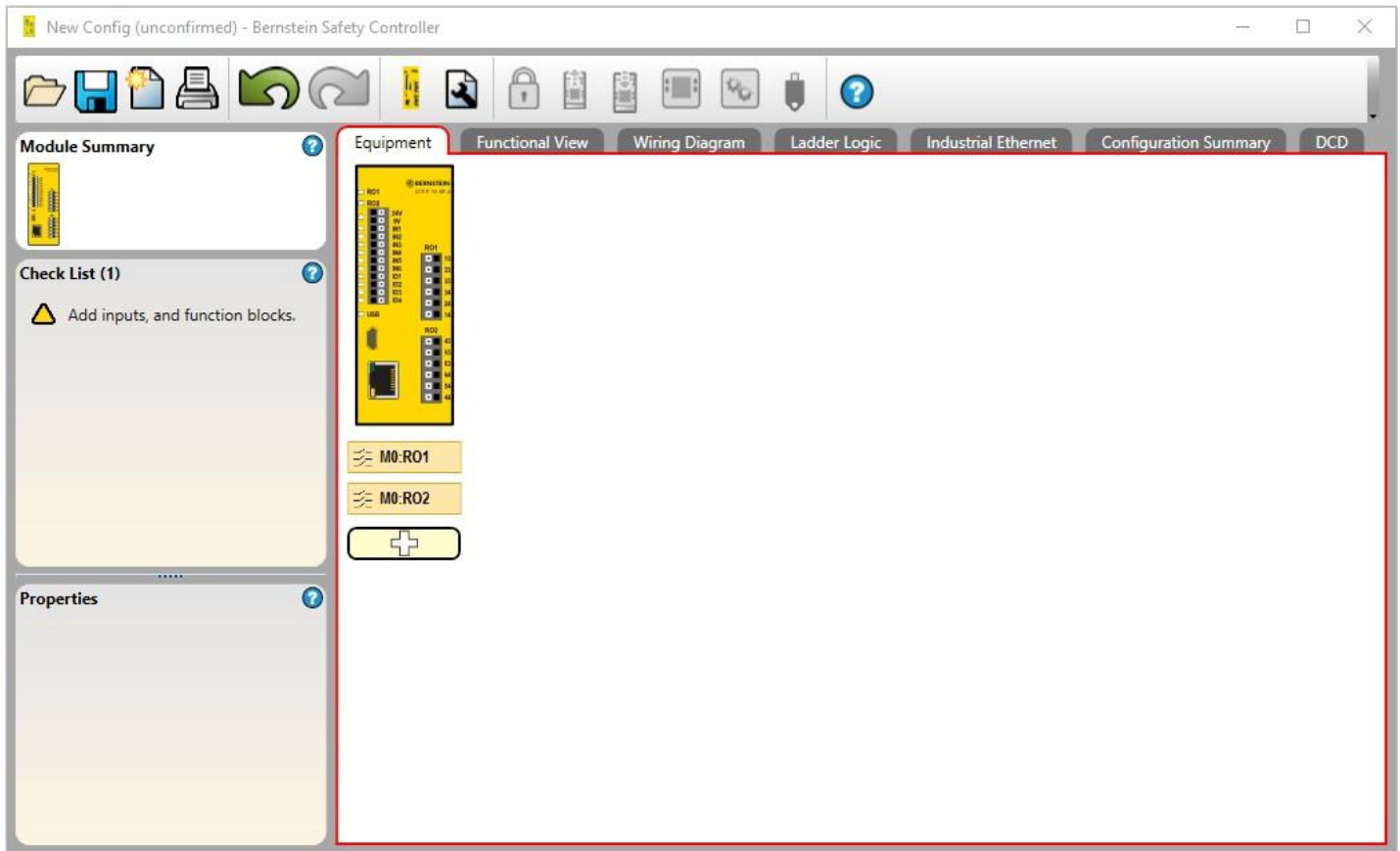

Figure 41: Example Equipment Tab

**SCR P:** The **Equipment** tab is used to add input devices and status outputs.

Customize the Base Controller module or SCR P by either double-clicking the module or selecting it and clicking **Edit** under the **Properties** table on the left and selecting the appropriate Safety Controller features (display, Ethernet, expandability, Automatic Terminal Optimization). The properties of Safety and Non-Safety inputs, Status Outputs, Logic Blocks, and Function Blocks are also configured by either double-clicking the block or selecting it and clicking **Edit** under the **Properties** table. Clicking the block the second time de-selects it.

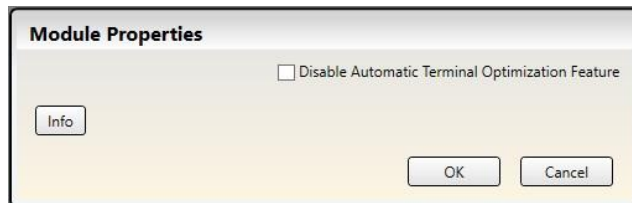

Figure 42: SCR P Module Properties



## 8.5 Functional View Tab

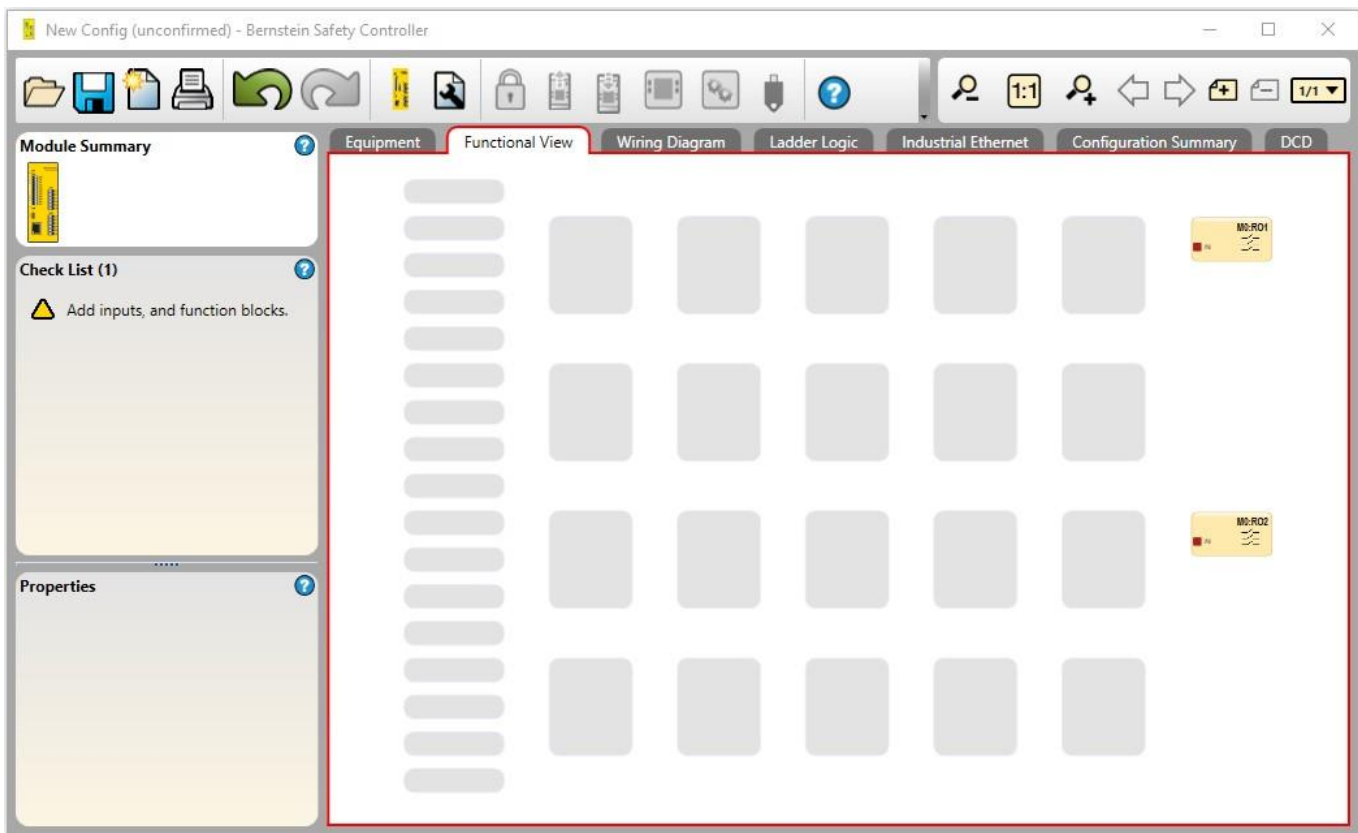

Figure 43: Functional View Tab

The **Functional View** tab is used to create the control logic. The left column of the **Functional View** tab is used for Safety and Non-Safety Inputs; the middle area is used for Logic and Function Blocks and the right column is reserved for Safety Outputs. Safety and Non-Safety Inputs can be moved between the left and middle areas. Function and Logic Blocks can only be moved within the middle area. Outputs are placed statically by the program and cannot be moved. Reference blocks of any type can be placed anywhere within the left and middle areas.



**Important:** The BERNSTEIN Safety Controller Software is designed to assist in creating a valid configuration, however, the user is responsible for verifying the integrity, safety, and functionality of the configuration by following the [Commissioning Checkout Procedure](#) on p. 165.

On the **Functional View** tab you can:

- Customize the look of the diagram by repositioning inputs, Function Blocks, and Logic blocks
- **Undo** and **Redo** up to 10 most recent actions
- Add additional pages for larger configurations using the page navigation toolbar.
- Zoom in and out of the diagram view, or automatically adjust it to the best ratio for the current window size.



Figure 44: Page Navigation and Diagram Size toolbar

- Navigate between pages by clicking the left and right arrows within the page navigation area in the top right corner of the Software

- Modify properties of all blocks by either double-clicking a block or by selecting a block and clicking **Edit** under the **Properties** table
- Delete any block or connection by selecting the item and then either pressing the **Delete** key on your keyboard or clicking **Delete** under the **Properties** table



**Note:** There is no confirmation of the object deletion. You may undo the deletion by clicking **Undo**.

By default, all inputs added on the **Equipment** tab are placed on the **Functional View** tab to the first available placeholder in the left column. There are two ways to move signals from one page to another. To do so, perform one of the following steps:

1. Add a **Reference** to the block located on a different page—click any of the empty placeholders in the middle area, select **Reference** and select the block that is on the next page. Only blocks from other pages can be added as a **Reference**.
2. Re-assign page—on the page where you want to keep the configuration, move one of the blocks to any of the placeholders in the middle area. Go to the page which contains the block that needs to be moved. Select the block and change the page assignment below the **Properties** table.

## 8.6 Logic Blocks

Logic Blocks are used to create Boolean (True or False) functional relationships between inputs, outputs, and other logic and function blocks. Logic Blocks accept appropriate safety inputs, non-safety inputs, or safety outputs as an input. The state of the output reflects the Boolean logic result of the combination of the states of its inputs (**1** = On, **0** = Off, **x** = do not care).



### CAUTION: Inverted Logic

It is not recommended to use Inverted Logic configurations in safety applications where a hazardous situation can occur.

Signal states can be inverted by the use of NOT, NAND, and NOR logic blocks, or by selecting "Invert Output" or "Invert Input Source" check boxes (where available). On a Logic Block input, inverted logic treats a Stop state (0 or Off) as a "1" (True or On) and causes an output to turn On, assuming all inputs are satisfied. Similarly, the inverted logic causes the inverse function of an output when the block becomes "True" (output turns from On to Off). Because of certain failure modes that would result in loss of signal, such as broken wiring, short to GND/0 V, loss of safeguarding device supply power, etc., inverted logic is not typically used in safety applications. A hazardous situation can occur by the loss of a stop signal on a safety input, resulting in a safety output turning On.

### AND

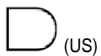

(US)



(EU)

The output value is based on the logical AND of 2 to 5 inputs.

Output is On when all inputs are On.

Input 1	Input 2	Output
0	x	0
x	0	0
1	1	1

### OR



(US)



(EU)

The output value is based on the logical OR of 2 to 5 inputs.

Output is On when at least one input is On.

Input 1	Input 2	Output
0	0	0
1	x	1
x	1	1

## NAND

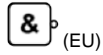
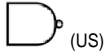

The output value is based on inverting the logical AND of 2 to 5 inputs.  
Output is Off when all inputs are On.

Input 1	Input 2	Output
0	x	1
x	0	1
1	1	0

## NOR

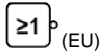
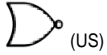

The output value is based on inverting the logical OR of 2 to 5 inputs.  
Output is On when all inputs are Off.

Input 1	Input 2	Output
0	0	1
1	x	0
x	1	0

## XOR



The output value is an exclusive OR of 2 to 5 inputs.  
Output is On when only one (exclusive) input is On.

Input 1	Input 2	Output
0	0	0
0	1	1
1	0	1
1	1	0

## NOT

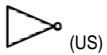

Output is the opposite of the input.

Input	Output
0	1
1	0

## RS Flip-Flop



This block is Reset Dominant (Reset has priority if both inputs are On).

Input 1 (Set)	Input 2 (Reset)	Output
0	0	Value remains the same
0	1	0 (Reset)
1	0	1 (Set)
1	1	0 (Reset has priority)

## SR Flip-Flop



This block is Set Dominant (Set has priority if both inputs are On).

Input 1 (Set)	Input 2 (Reset)	Output
0	0	Value remains the same
0	1	0 (Reset)
1	0	1 (Set)
1	1	1 (Set has priority)

## 8.7 Function Blocks

Function Blocks provide built-in functionality for most common applications in one block. While it is possible to design a configuration without any function blocks, using the Function Blocks offers substantial efficiency, ease of use, and improved functionality.

Most Function Blocks expect the corresponding safety input device to be connected to it. The **Check List** on the left creates a notification if any required connections are missing. Depending on the application, some Function Blocks may be connected to other Function Blocks and/or Logic Blocks.

Dual-channel safety input devices have two separate signal lines. Dual-channel signals for some devices are both positive (+24 V dc) when the device is in the Run state. Other devices may have a complementary circuit structure where one channel is at 24 V dc and the other is at 0 V dc when the device is in the Run state. This manual uses the Run state/Stop state convention instead of referring to a safety input device as being On (24 V dc) or Off (0 V dc).

### Bypass Block

Default Nodes	Additional Nodes	Notes
IN BP	-	When the BP node is inactive, the safety signal simply passes through the Bypass Block. When the BP node is active, the output of the block is On regardless of the state of the IN node (if the <b>Output turns Off when both inputs (IN&amp;BP) are On</b> checkbox is clear). The Bypass Block output turns Off when the bypass timer expires.

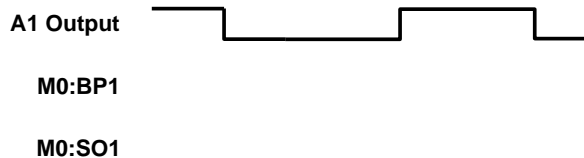
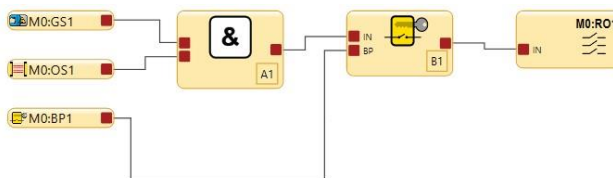
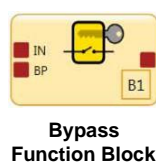

Figure 45: Timing Diagram—Bypass Block

**Bypass Time Limit**—A bypass function time limit must be established to limit how long the safety input device bypass is active. The time limit can be adjusted from 1 second (default) to 12 hours and cannot be disabled. Only one time limit can be set, and this limit will apply to all safety devices that are bypassed. At the end of the time limit, the safety output control authority is transferred back to the bypassed safety input devices.

**Two-Hand Control Bypassing**—The Safety Controller issues a Stop signal if a Two-Hand Control input is actuated while the input is being bypassed. This ensures that the operator does not mistakenly assume that the Two-Hand Control is functional; unaware that the Two-Hand Control is bypassed and no longer providing the safeguarding function.

## Lockout/Tagout

Hazardous energy (lockout/tagout) must be controlled in machine maintenance and servicing situations in which the unexpected energization, start up, or release of stored energy could cause injury. Refer to OSHA 29CFR 1910.147, ANSI 2244.1, ISO 14118, ISO 12100 or other relevant standards to ensure that bypassing a safeguarding device does not conflict with the requirements that are contained within the standards.



### WARNING: Limit Use of Bypass Function

**The Bypass function is not intended for production purposes; it is to be used only for temporary or intermittent actions, such as to clear the defined area of a safety light screen if material becomes "stuck".** When Bypass is used, it is the user's responsibility to install and use it according to relevant standards (such as ANSI NFPA79 or IEC/EN60204-1).

## Safe Working Procedures and Training

Safe work procedures provide the means for individuals to control exposure to hazards through the use of written procedures for specific tasks and the associated hazards. The user must also address the possibility that an individual could bypass the safeguarding device and then either fail to reinstate the safeguarding or fail to notify other personnel of the bypassed condition of the safeguarding device; both cases could result in an unsafe condition. One possible method to prevent this is to develop a safe work procedure and ensure personnel are trained and correctly follow the procedure.

## Delay Block

The Delay Block allows a user-configurable ON or OFF delay of a maximum of 5 minutes, in 1 ms increments.

Default Nodes	Additional Nodes	Notes
IN	-	Depending on the selection, a signal/state transition on the input node will be delayed by the output delay time by either holding the output OFF (ON Delay) or holding the output ON (OFF Delay) after a signal transition.



**Note:** The actual delay time of a delay function block or a safety output with a delay can be up to 1 scan time longer than the delay setting. Multiple delay blocks or delay outputs in series will increase the final delay time by up to 1 scan for each delay function. For example, three 100 ms off delay function blocks in series and a scan time of 15 ms may result in an actual delay time of up to 345 ms (300 ms + 45 ms).

The Cancel Delay Node is a configurable node if Off Delay is selected.

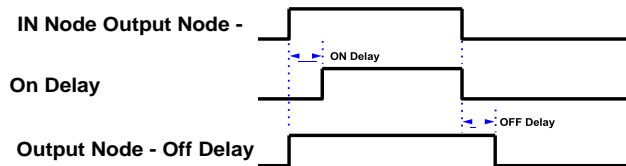

Figure 46: Delay Block Timing Diagram



### CAUTION: Delay time effect on response time

The off delay time may significantly increase the safety control response time. This will impact the positioning of safeguards whose installation is determined by the safety (minimum) distance formulas or are otherwise influenced by the amount of time to reach a non-hazardous state. The installation of safeguards must account for the increase in response time.



**Note:** The response time provided on the **Configuration Summary** tab is a maximum time that can change depending on the use of delay blocks and other logic blocks (such as OR functions). It is the user's responsibility to determine, verify, and incorporate the appropriate response time.



Figure 47: Delay Block Properties

The **Delay Block Properties** window allows the user to configure the following:

**Name**

The input designation.

**Safety Output Delay**

- None
- Off Delay
- On

**Delay Output**

**Delay**

Available when the Safety Output Delay is set to either Off Delay or On Delay

Delay time: 1 ms to 5 minutes, in 1 ms increments. The default setting is 100 ms.

**Cancel Type**

Available when the Safety Output Delay is set to Off Delay.

- Do Not Cancel
- Control Input
- Cancel Delay

**Node End Logic**

Available when the Cancel Type is set to Cancel Delay Node.

- Keep Output On
- Turn Output Off

## Enabling Device Block

Default Nodes	Additional Nodes	Notes
ED IN RST	ES JOG	An Enabling Device Block must be connected directly to an Output Block. This method assures that the final control of the outputs is given to the operator holding the Enabling Device. Use the ES node for safety signals that should not be bypassed by the ED node. If no other inputs of the function block are configured, using an Enabling Device function block is not required.

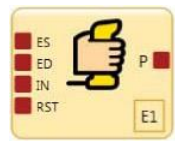

**Enabling Device Function Block**

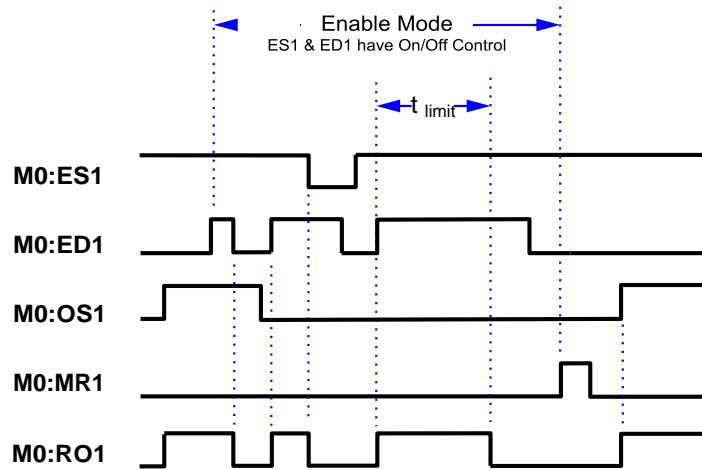
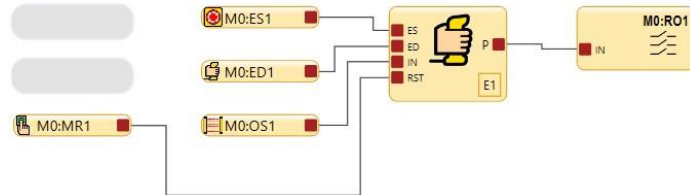
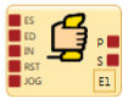
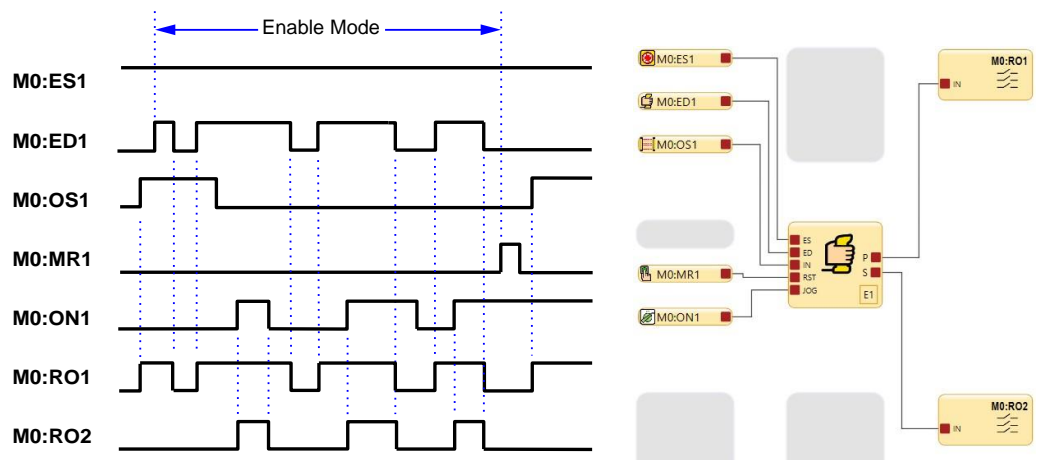

Figure 48: Timing Diagram—Enabling Device, Simple Configuration



**Enabling Device Primary & Secondary Output Control**



E1 enabling mode starts when the Enabling Device ED1 is switched to the Run state. ED1 and ES input devices have On/Off control authority while in Enable mode. When MR1 is used to perform a reset, the normal Run mode is re-established and OS1 and ES1 have the On/Off control authority.

Figure 49: Timing Diagram—Enabling Device

**To exit the Enable mode**, the enabling device must be in the Off state, and an Enabling Device Block reset must be performed.

**The enabling device time limit** may be adjusted between 1 second (default) and 30 minutes and cannot be disabled. When the time limit expires, the associated safety outputs turn Off. To start a new Enable mode cycle, with the time limit reset to its original value, the enabling device must switch from On to Off, and then back to On.

All On- and Off-delay time limits associated with the safety outputs that are controlled by the enabling device function are followed during the Enable mode.

## Latch Reset Block

Default Nodes	Additional Nodes	Notes
IN LR	RE	The RE (Reset Enable) node can be used to enable or disable the Latch Reset function. If the input devices connected to the IN node are all in the Run state and RE input signal is high, the LR function block can be manually reset to have its output turn On. See <a href="#">Figure 68</a> on p. 86 with Reference Signal SO2 connected to the RE node.

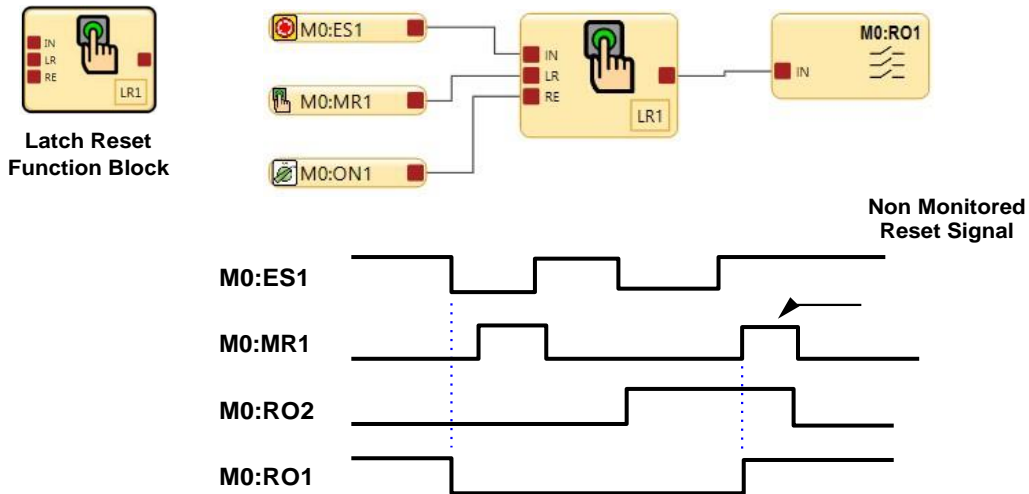

The Latch Reset function block LR1 will turn its output and the safety output RO1 Off when the E-Stop button changes to the Stop state. The latch off condition can be reset when the Reset Enable RE of LR1 detects that the RO2 reference signal is in the Run state & MR1 is used to perform a reset.

Figure 50: Timing Diagram—Latch Reset Block



**M0:MR1**  
Manual Reset Input

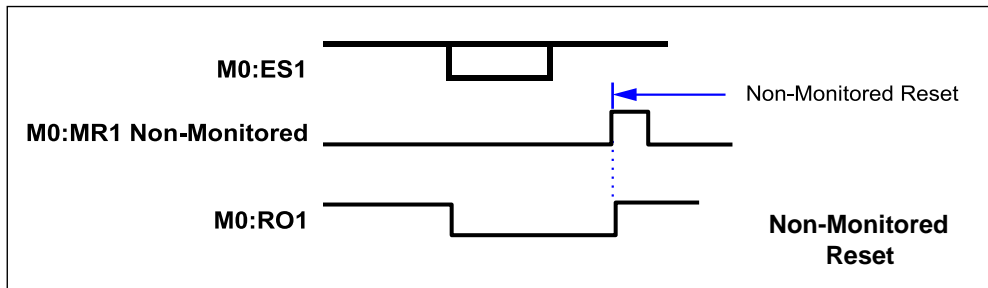
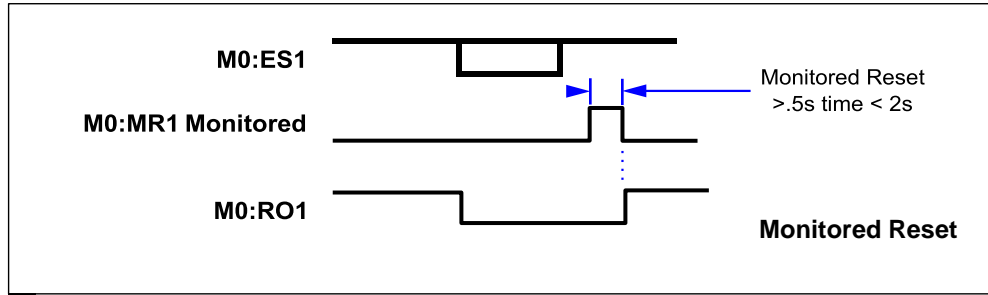

The Manual Reset input device can be configured for one of two types of reset signals:  
Monitored & Non-Monitored

Figure 51: Timing Diagram—Latch Reset Block, Monitored/Non-Monitored Reset



**Reference Signals**

- A Reference Signal is used to:
- Control an output based on the state of another output
  - Represent the state of an output, input, safety function or logic block on another page.

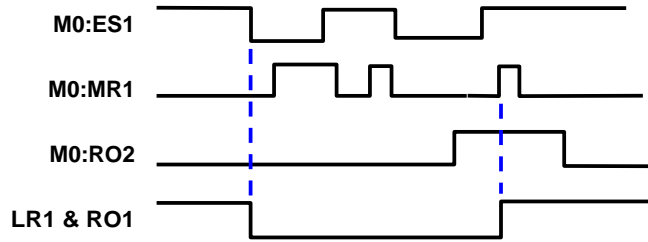
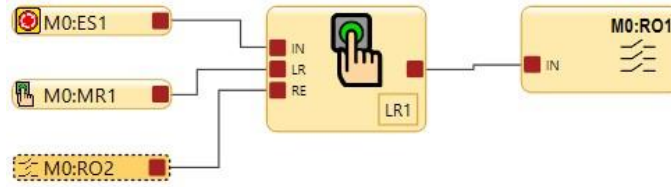

When output RO2 is On, the RO2 reference signal state is On or High. The function block above shows reference signal SO2 connected to the Reset Enable node RE of Latch Reset Block LR1.

LR1 can only be reset (turned On) when ES1 is in the Run state and RO2 is On.

See [Reference Signals](#) on p. 108 for use of referenced Safety Outputs.

Figure 52: Timing Diagram—Latch Reset Block and Referenced Safety Output



In the figure below, reference signal A3 is on page 1 of the function block diagram and the A3 AND block is on page 2. The output node on the A3 AND block can also be used on page 2 for other safety control logic.

**Reference Signals**

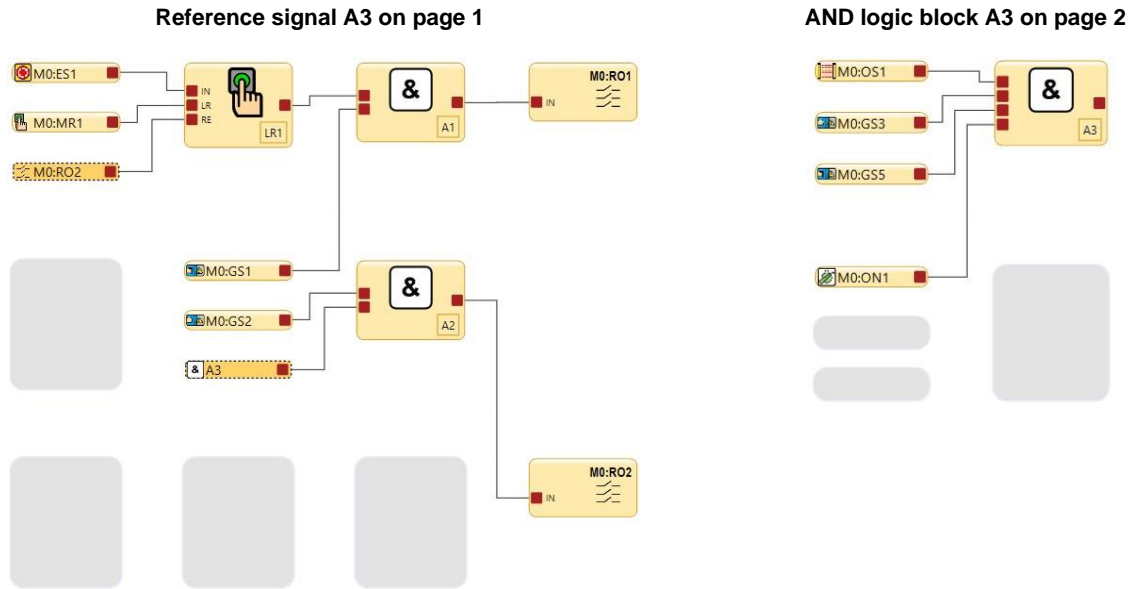
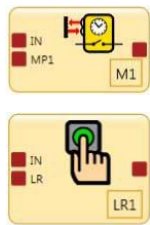
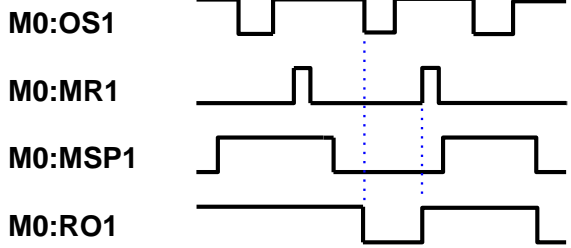
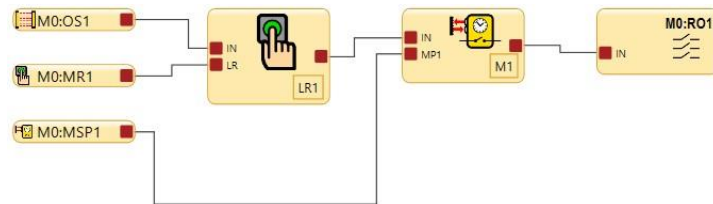

Figure 53: Latch Reset and Referenced Safety Output and AND block



**Latch Reset Mute Function**



When a safeguarding device OS1 transitions to a Stop state in a valid muting cycle, the latch reset function block will latch and require a reset signal to keep SO1 on after muting ends.

If OS1 switches to the Stop state in a valid muting cycle and no reset signal is seen, RO1 turns off after muting ends.

Figure 54: Timing Diagram—Latch Reset Block and Muting Block

## Muting Block

Default Nodes	Additional Nodes	Notes
IN MP1	ME BP MP2	Muting Sensor Pair input blocks must be connected directly to the Muting function block.

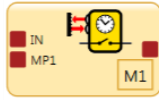

**Mute Function Block**

There are five Mute Function types listed below. The following timing diagrams show the function detail and sensor/safeguarding state change order for each mute function type.

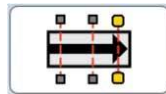

**One Way - 1 Mute Sensor Pair**

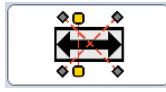

**Two Way - 1 Mute Sensor Pair**

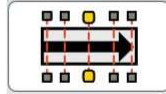

**One Way - 2 Mute Sensor Pair**

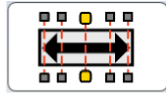

**Two Way - 2 Mute Sensor Pair**

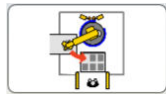

**Two Way - 1 Mute Sensor Pair**

Figure 55: Muting Block—Function Types

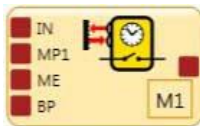

- There are 2 types of Mute Bypass:
- Mute Dependent Override
  - Bypass (normal)

In the Mute Block Properties menu in the Advanced settings, if the Bypass check box is checked, the option to select a Bypass or a Mute Dependent Override is possible.

The Mute Dependent Override is used to temporarily restart an incomplete mute cycle (for example after the mute time limit expires). In this case, one or more mute sensors must be activated while the safeguard is in the Stop state.

The normal Bypass is used to temporarily bypass the safeguarding device to keep on or turn on the output of the function block.

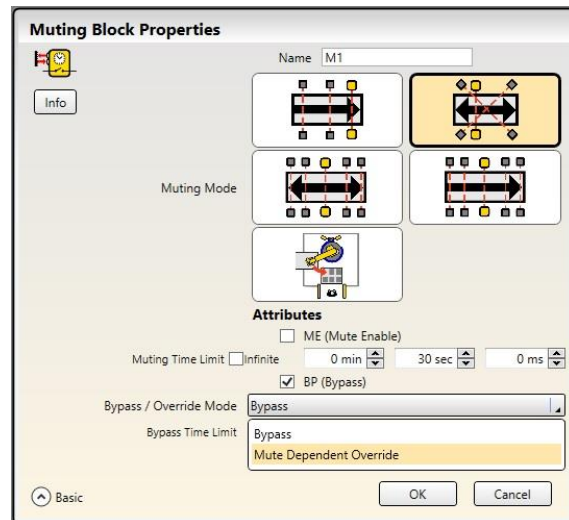

Figure 56: Muting Block—Bypass/Override Mode Options

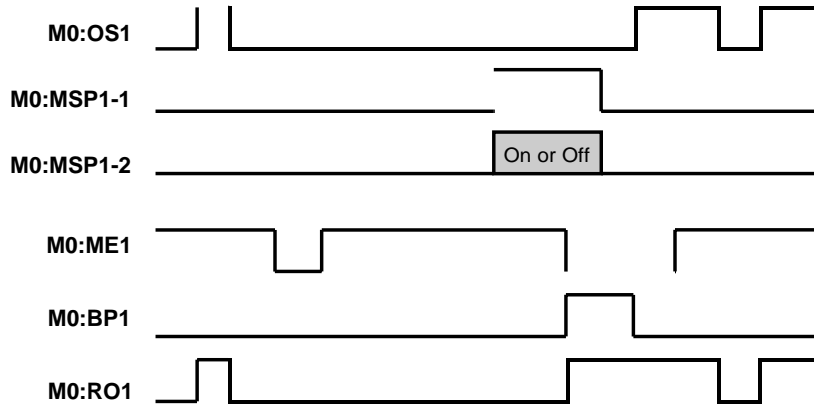
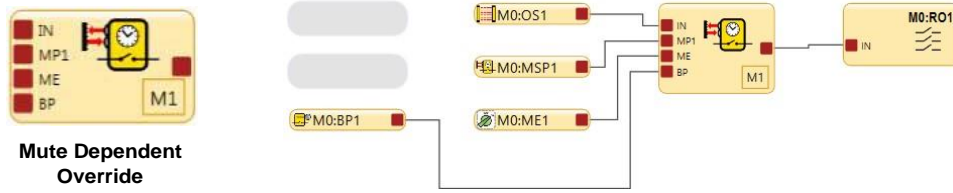

Figure 57: Mute-Dependent Override

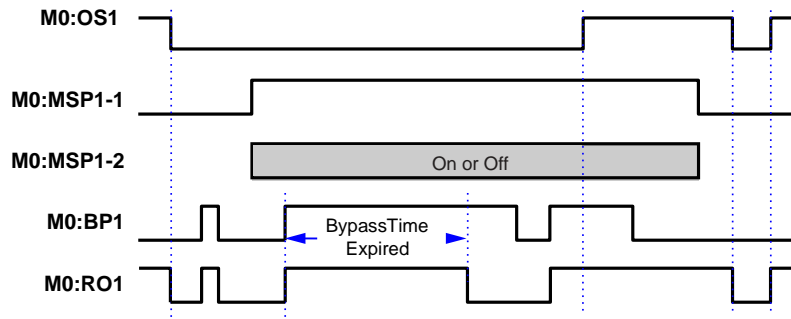
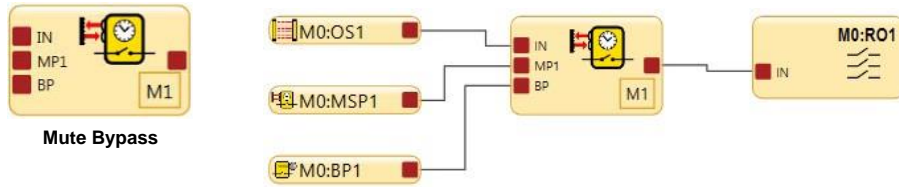
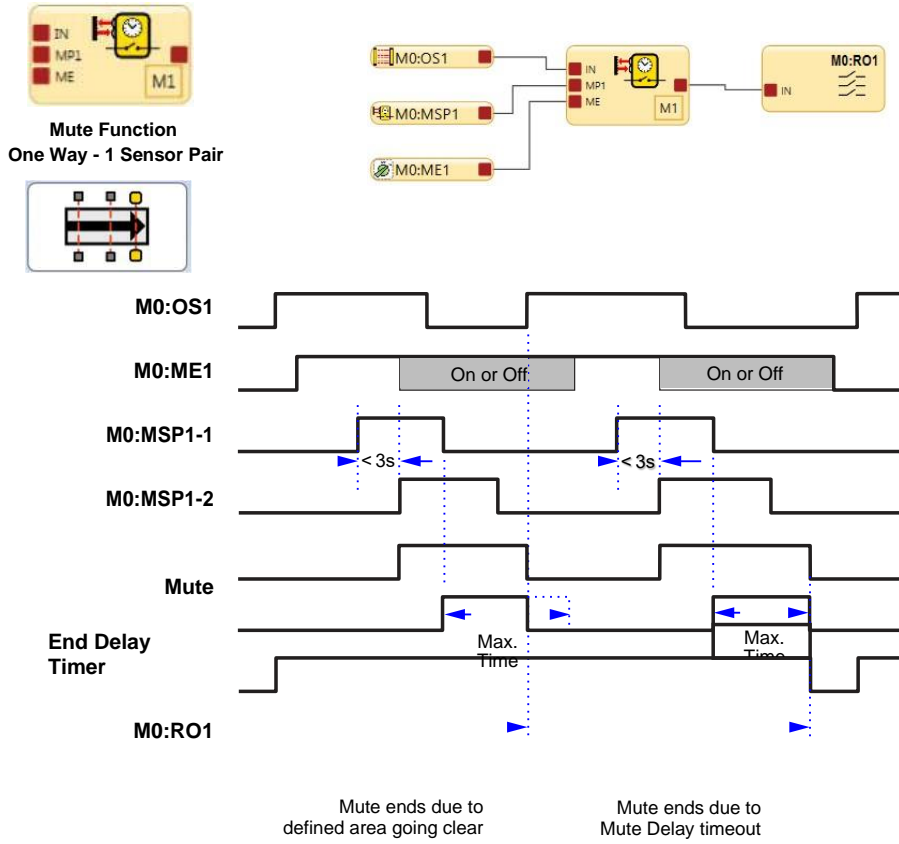

Figure 58: Mute Bypass



**Note:** M0:OS1 must be blocked before either MSP1-1 or MSP1-2 clears.

Figure 59: Timing Diagram—One-Way Muting Block, One Muting Sensor Pair

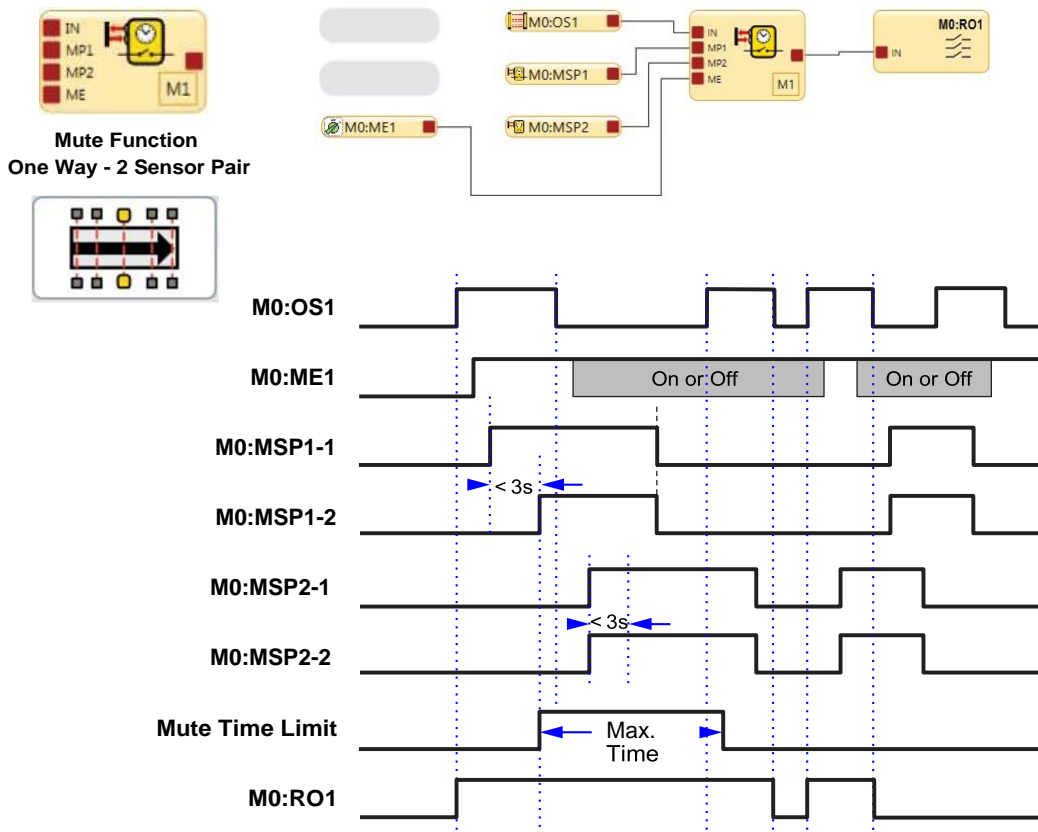
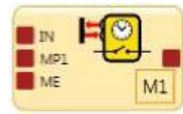

Figure 60: Timing Diagram—One-Way Muting Block, Two Muting Sensor Pairs



**Mute Function  
Two Way - 1 Sensor  
Pair**

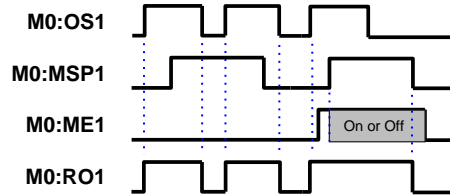
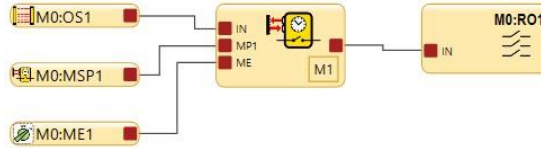
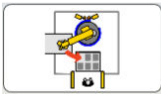
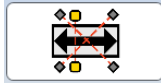
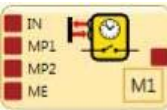

Figure 61: Timing Diagram—Two-Way Muting Block, One Muting Sensor Pair



**Mute Function  
Two Way - 2 Sensor  
Pair**

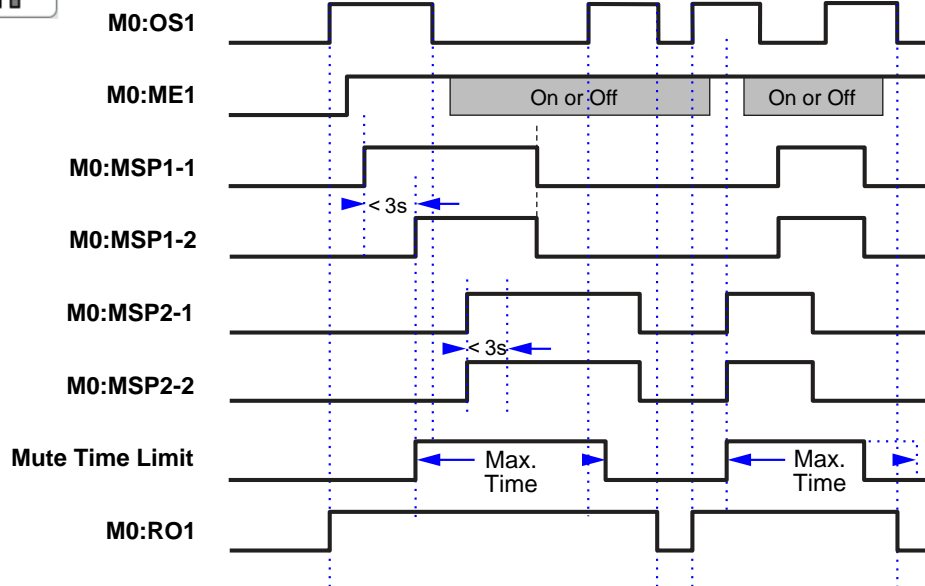
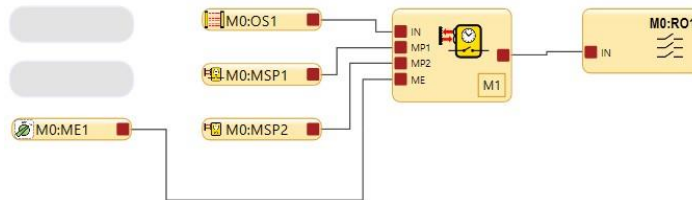
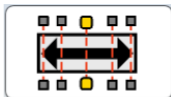

Figure 62: Timing Diagram—Two-Way Muting Block, Two Muting Sensor Pairs

**⚠ WARNING E-Stop Button control authority when using the Mute function**

**Improper E-Stop Control  
NOT RECOMMENDED**

The configuration top right shows OS1 and E-Stop button ES1 with a Latch Reset LR1 connected to a mute function via the AND function. In this case both ES1 and OS1 will be muted.

If there is an active mute cycle in progress and the E-Stop button is pressed (switched to the Stop state), RO1 will not turn Off. This will result in a loss of safety control and may lead to a potentially hazardous condition.

**Proper E-Stop Control**

The configuration to the right shows OS1 connected directly to the Mute block M1. M1 and ES1 are both inputs to AND A1. In this case both M1 and ES1 control RO1.

If there is an active mute cycle in progress and the E-Stop button is pressed (switched to the Stop state), RO1 will turn Off.

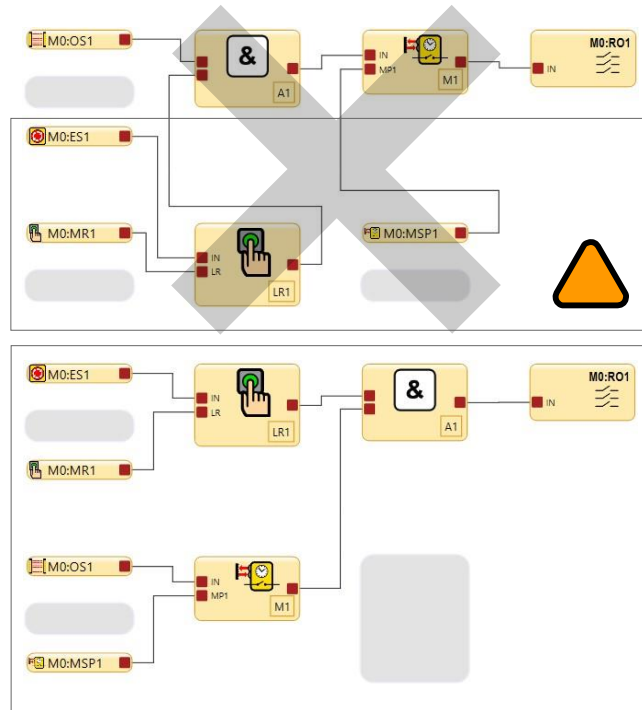

Figure 63: Emergency Stop and Mute Function

E-stop buttons, rope pulls, enabling devices, external device monitoring, and bypass switches are non-mutable devices or functions.

To mute the primary safeguard appropriately, the design of a muting system must:

1. Identify the non-hazardous portion of the machine cycle.
2. Involve the selection of the proper muting devices.
3. Include proper mounting and installation of those devices.



**WARNING:**

- **Use Mute and Bypass operations in a way that minimizes personnel risk.**
- Failure to follow these rules could cause an unsafe condition that could result in serious injury or death.
- Guard against unintended stop signal suspension by using one or more diverse-redundant mute sensor pairs or a dual channel key-secured bypass switch.
- Set reasonable time limits for the mute and bypass functions.

The Safety Controller can monitor and respond to redundant signals that initiate the mute. The mute then suspends the safeguarding function by ignoring the state of the input device to which the muting function has been assigned. This allows an object or person to pass through the defined area of a safety light screen without generating a stop command. This should not be confused with blanking, which disables one or more beams in a safety light screen, resulting in larger resolution.

The mute function may be triggered by a variety of external devices. This feature provides a variety of options to design the system to meet the requirements of a specific application.

A pair of muting devices must be triggered simultaneously (within 3 seconds of one another). This reduces the chance of common mode failures or defeat. Directional muting, in which sensor pair 1 is required to be blocked first, also may reduce the possibility of defeat.

At least two mute sensors are required for each muting operation. The muting typically occurs 100 ms after the second mute sensor input has been satisfied. One or two pairs of mute sensors can be mapped to one or more safety input devices so that their assigned safety outputs can remain On to complete the operation.





**WARNING: Muting Limitations**

Muting is allowed only during the non-hazardous portion of the machine cycle.  
A muting application must be designed so that no single component failure can prevent the stop command or allow subsequent machine cycles until the failure is corrected.



**WARNING: Mute Inputs Must Be Redundant**

**It is not acceptable to use a single switch, device, or relay with two N.O. contacts for the mute inputs.**  
This single device, with multiple outputs, may fail so that the System is muted at an inappropriate time.  
**This could result in a hazardous situation.**

**Optional Muting Attributes**

The Muting Sensor Pair Input and the Muting Block have several optional functions that can be used to minimize an unauthorized manipulation and the possibility of an unintended mute cycle.

*Mute Enable (ME)*

The Mute Enable input is a non-safety-rated input. When the input is closed, or active for virtual input, the Safety Controller allows a mute condition to occur; opening this input while the System is muted will have no effect.

Typical uses for Mute Enable include:

- Allowing the machine control logic to create a period of time for muting to begin
- Inhibiting muting from occurring
- Reducing the chance of unauthorized or unintended bypass or defeat of the safety system

The optional Mute Enable function may be configured to ensure that a mute function is permitted only at the appropriate time. If a Mute Enable input device has been mapped to a Muting Block, the safety input device can be muted only if the mute enable switch is in the enable (24 V dc) state, or active state for virtual input, at the time the mute cycle is started. A mute enable input device can be mapped to one or more Muting Blocks.

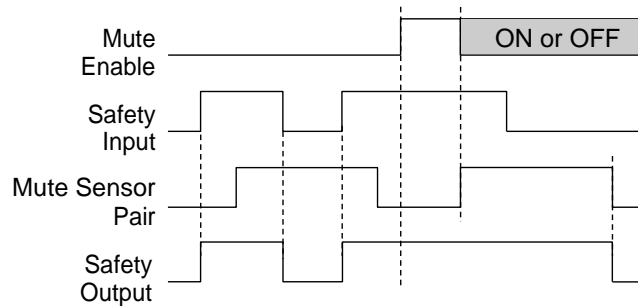

Figure 64: Timing logic—One mute sensor pair with mute enable

**Simultaneity Timer Reset Function**

The Mute Enable input can also be used to reset the simultaneity timer of the mute sensor inputs. If one input is active for longer than 3 seconds before the second input becomes active, the simultaneity timer prevents a mute cycle from occurring. This could be due to a normal stoppage of an assembly line that may result in blocking one mute device and the simultaneity time running out.

If the ME input is cycled (closed-open-closed or active-inactive-active for virtual input) while one mute input is active, the simultaneity timer is reset, and if the second mute input becomes active within 3 seconds, a normal mute cycle begins. The function can reset the timer only once per mute cycle (all mute inputs M1–M4 must open before another reset can occur).

*Bypass*

An optional **Bypass/Override Mode** may be enabled by checking the **BP (Bypass)** box in the **Muting Block** properties window. There are two available Bypass/Override Modes—**Bypass** and **Mute Dependent Override**. The **Bypass** mode is used to temporarily bypass the safeguarding device to keep On or turn On the output of the function block. The **Mute Dependent Override** mode is used to manually override an incomplete mute cycle (for example after the mute time limit expires). In this case, one or more mute sensors must be activated while the safeguard is in the Stop state to initiate the override.

*Mute Lamp Output (ML)*

Depending on a risk assessment and relevant standards, some applications require that a lamp (or other means) be used to indicate when the safety device, such as a light screen, is muted. The Safety Controller provides a signal that the protective function is suspended through the Mute status output.



**Important: Mute Status Indication**

Indication that the safety device is muted must be provided and be readily observable from the location of the muted safety device. Operation of the indicator may need to be verified by the operator at suitable intervals.

*Muting Time Limit*

The muting time limit allows the user to select a maximum period of time that muting is allowed to occur. This feature hinders the intentional defeat of the muting devices to initiate an inappropriate mute. It is also useful for detecting a common mode failure that would affect all mute devices in the application. The time limit can be adjusted from 1 second to 30 minutes, in increments of 100 milliseconds (the default is 30 s). The mute time limit may also be set to **Infinite** (disabled).

The timer begins when the second muting device meets the simultaneity requirement (within 3 seconds of the first device). After the timer expires, the mute ends despite what the signals from the mute devices indicate. If the input device being muted is in an Off state, the corresponding Muting Block output turns off.



**WARNING: Muting Time Limit.** Select an infinite time for the Muting Time Limit only if the possibility of an inappropriate or unintended mute cycle is minimized, as determined, and allowed by the machine's risk assessment. The user is responsible to make sure that this does not create a hazardous situation.

*Mute Off-Delay Time*

A delay time may be established to extend the Mute state up to the selected time (1, 2, 3, 4, or 5 seconds) after the Mute Sensor Pair is no longer signaling a muted condition. Off-delay is typically used for Safety Light Screen/Grid workcell "Exit Only" applications with mute sensors located only on one side of the defined area. The Muting Block output will remain On for up to 5 seconds after the first mute device is cleared, or until the muted Safety Input device (Mute Block In) returns to a Run state, whichever comes first.

*Mute on Power-Up*

This function initiates a mute cycle after power is applied to the Safety Controller. If selected, the Mute on Power-Up function initiates a mute when:

- The Mute Enable input is On (if configured)
- The safety device inputs are active (in Run mode)
- Mute sensors M1-M2 (or M3-M4, if used, but not all four) are closed

If **Auto Power-Up** is configured, the Safety Controller allows approximately 2 seconds for the input devices to become active to accommodate systems that may not be immediately active at power-up.

If **Manual Power-Up** is configured and all other conditions are satisfied, the first valid Power-Up Reset after the muted safety inputs are active (Run state or closed) will result in a mute cycle. The Mute On Power-up function should be used only if safety can be assured when the mute cycle is expected, and the use of this function is the result of a risk assessment and is required by that particular machine operation.



**WARNING:** The Mute on Power-Up should be used only in applications where:

- Muting the System (MP1 and MP2 closed) when power is applied is required
- Using it does not, in any situation, expose personnel to hazard

*Mute Sensor Pair Debounce Times*

The input debounce times, accessible under the **Advanced** settings in the **Mute Sensor Pair** properties window, may be used to extend a mute cycle after a mute sensor signal is removed. By configuring the close-to-open debounce time, the mute cycle may be extended up to 1.5 seconds (1500 ms) to allow the Safety Input Device to turn On. The start of the mute cycle can also be delayed by configuring the open-to-close debounce time.

**Muting Function Requirements**

The beginning and the end of a mute cycle is triggered by signals from a pair of muting devices. The muting device circuit options are configurable and shown in the Mute Sensor Pair **Properties** window. A proper mute signal occurs when both channels of the mute device change to the Mute Active states while the muted safeguard is in the Run state.

The Safety Controller monitors the mute devices to verify that their outputs turn ON within 3 seconds of each other. If the inputs do not meet this simultaneity requirement, a mute condition cannot occur.

Several types and combinations of mute devices can be used, including, but not limited to photoelectric sensors, inductive proximity sensors, limit switches, positive-driven safety switches, and whisker switches.

### Corner Mirrors, Optical Safety Systems, and Muting

Mirrors are typically used with safety light screens and single-/multiple-beam safety systems to guard multiple sides of a hazardous area. If the safety light screen is muted, the safeguarding function is suspended on all sides. It must not be possible for an individual to enter the guarded area without being detected and a stop command issued to the machine control. This supplemental safeguarding is normally provided by an additional device(s) that remains active while the Primary Safeguard is muted. Therefore, mirrors are typically not allowed for muting applications.

### Multiple Presence-Sensing Safety Devices

Muting multiple presence-sensing safety devices (PSSDs) or a PSSD with multiple sensing fields is not recommended unless it is not possible for an individual to enter the guarded area without being detected and a stop command issued to the machine control. As with the use of corner mirrors (see [Corner Mirrors, Optical Safety Systems, and Muting](#) on p. 83), if multiple sensing fields are muted, the possibility exists that personnel could move through a muted area or access point to enter the safeguarded area without being detected.

For example, in an entry/exit application where a pallet initiates the mute cycle by entering a cell, if both the entry and the exit PSSDs are muted, it may be possible for an individual to access the guarded area through the "exit" of the cell. An appropriate solution would be to mute the entry and the exit with separate safeguarding devices.



#### **WARNING: Guarding Multiple Areas**

**Do not safeguard multiple areas with mirrors or multiple sensing fields, if personnel can enter the hazardous area while the System is muted, and not be detected by supplemental safeguarding that will issue a stop command to the machine.**

### Two-Hand Control Block

The TC input can be mapped directly to an output or to a logic block. The Two-Hand Control function block can be mapped directly to an output or to a logic block.

If the machine has multiple operators and each operator must actuate their two-hand controls, use the Two-Hand Control function block in which multiple TC inputs can be selected.

If the system has a hold function (TC inputs causing an action that makes it safe, then the operators can remove their hands while the process finishes), use the Two-Hand Control function block with the Muting function selected.

If the machine has certain safety devices that should be satisfied (and must stay satisfied) for the TC input to make the machine operate, use the Two-Hand Control function block with the IN node selected.

- If the IN node is off, engaging the Two-Hand input results in no actions.
- If the Two-Hand Control function block is on and the TC block goes off, the output turns off.
- When the IN node goes back high, the output stays off until the TC inputs goes off and back high.



#### **WARNING:**

- Two-Hand Controls are starting devices (initiate hazardous motion).
- Failure to follow these instructions could result in serious injury or death.
- The Qualified Individual must ensure that activation (going to the ON condition) of a stopping safety device (E-Stop, Rope Pull, Optical Sensor, Safety Mat, Protective Stop, etc.) by a user does not initiate hazardous motion when logically connected to a TC Input or Two-Hand Control function block that is already activated (ON condition).

## Two-Hand Control Block

Default Nodes	Additional Nodes	Notes
TC (up to 4 TC nodes)	IN MP1 ME	Two-Hand Control inputs must connect either directly to a Two-Hand Control Block or indirectly through a Bypass Block connected to a Two-Hand Control Block. It is not possible to use a Two-Hand Control input without a Two-Hand Control Block. Use the IN node to connect input devices that must be on before the THC can turn the outputs on.



**Two-Hand Control Function Block**

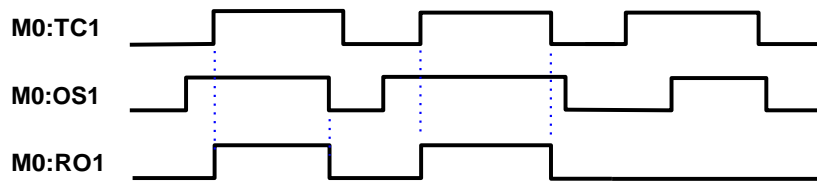
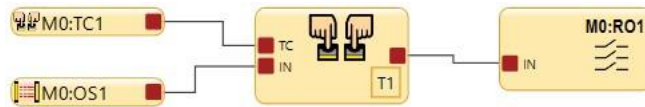

Either the TC1 input or the OS1 input has turn Off authority.  
OS1 needs to be in the Run state before TC1 can turn the output of T1 & RO1 On.

Figure 65: Timing Diagram—Two-Hand Control Block

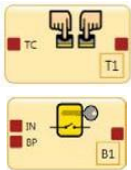

**Two-Hand Control & Bypass Function Blocks**

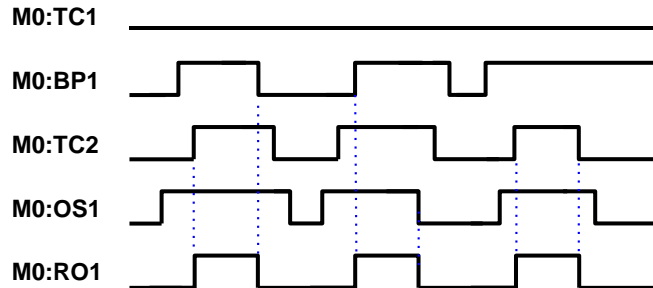
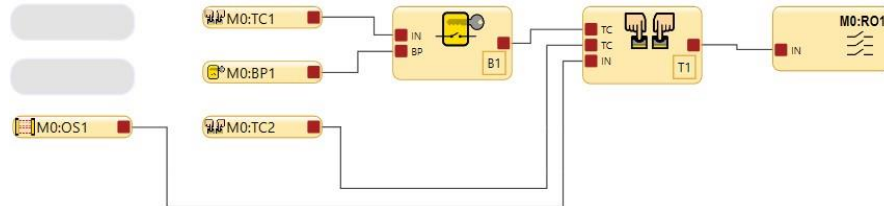

The Two-Hand Control actuators TC2 and the Bypass Switch BP1 need to be in the Run state and need to be the last devices in time to transition to the Run state for the TC1 function block to turn On.

Figure 66: Timing Diagram—Two-Hand Control Block and Bypass Blocks

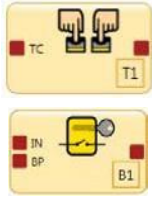

**Two-Hand Control & Bypass Function Blocks**

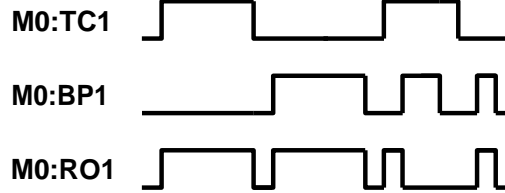
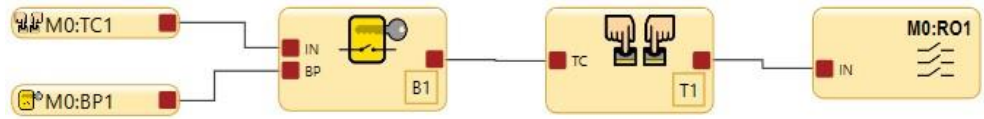

If both TC1 actuators and the BP1 Bypass switch active at the same time, the B1 Bypass function block output and the Two-Hand Control function block output turn Off. The outputs for B1 and T1 will only turn On when either the TC1 actuators or the BP1 switch are in the Run state.

Figure 67: Timing Diagram—Two-Hand Control Block and Bypass Blocks with 1 Two-Hand Control Input

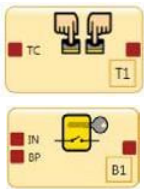

**Two-Hand Control & Bypass Function Blocks**

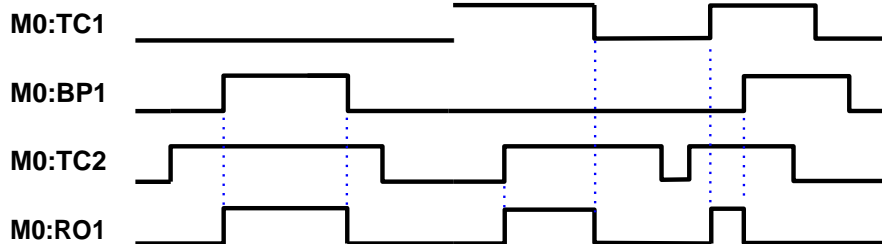
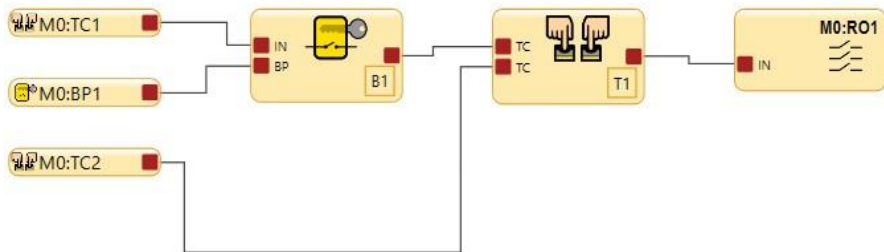

The Bypass function can be used with the TC2 actuators to turn the Safety Output On. When the TC1 actuators are not bypassed they must be used along with the TC2 actuators to turn the Safety Output On. If the TC1 actuators and the Bypass switch are both in the Run state, T1 and RO1 cannot be turned On or will turn Off.

Figure 68: Timing Diagram—Two-Hand Control Block and Bypass Blocks with 2 Two-Hand Control Inputs

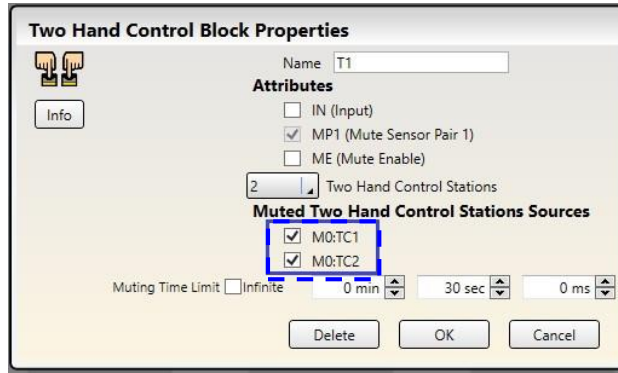

To configure the Two-Hand Control mute option, the TC actuators first need to be connected to the Two-Hand Control function block in the Function View. Check boxes (blue square above) in the Properties menu will display the names of all TC actuator input devices. Only those THC station boxes that are checked will be muted.

Figure 69: Two-Hand Control Muting Options

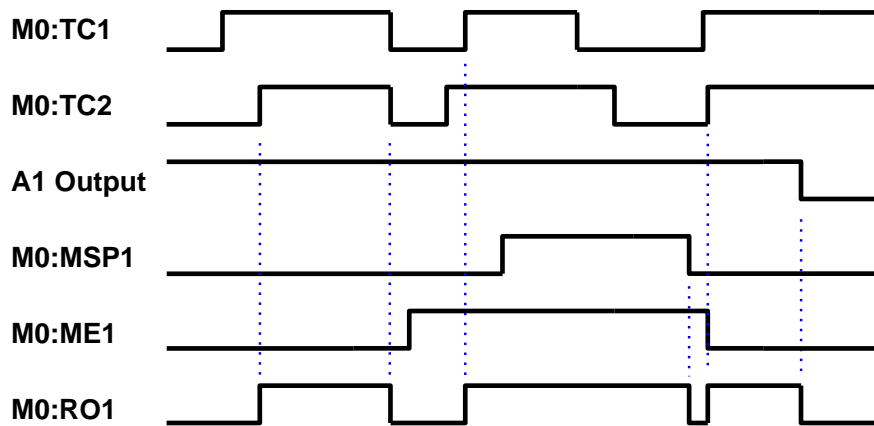
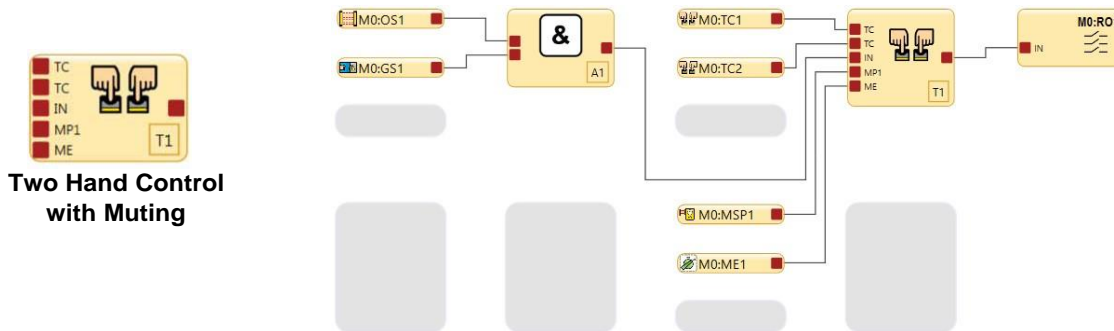

Actuators TC1 and TC2 can initiate a two-hand cycle if the mute enable ME1 is not active. ME1 must be active for the MSP1 mute sensors to keep the SO On after the TC1 and TC2 actuators are in the Stop state.

Figure 70: Timing Diagram—Two-Hand Control Block with Muting

**Two-Hand Control Activation on Power-Up Protection.** The Safety Controller's two-hand control logic does not permit the assigned safety output to turn On when power is initially supplied while the THC actuators are in their Run state. The THC actuators must change to their Stop state and return to the Run state before the Safety Output can turn On. A Safety Output associated with a Two-Hand Control device will not have a manual reset option.

## 8.8 Wiring Diagram Tab

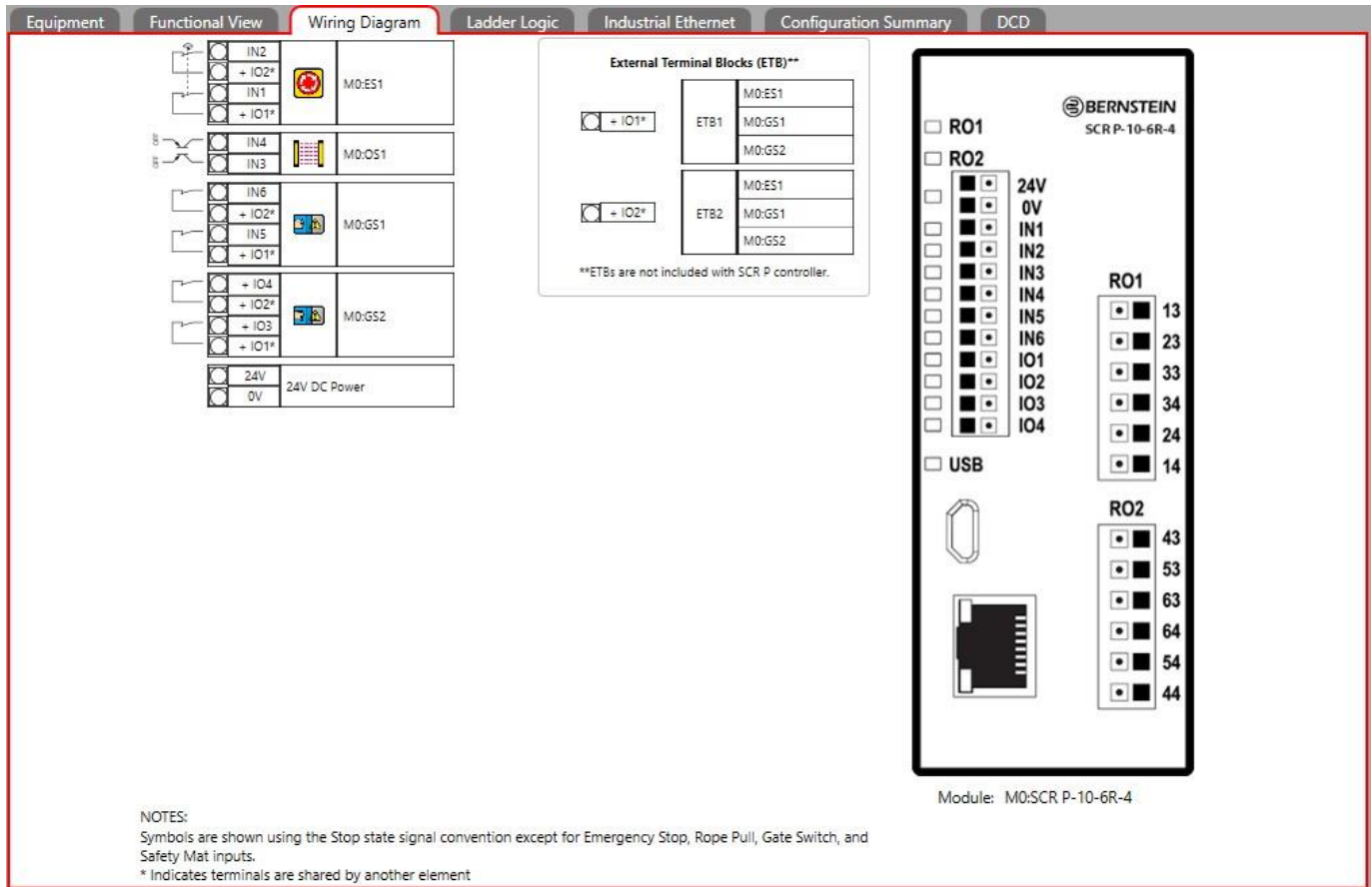

Figure 71: *Wiring Diagram Tab—SCR P with External Terminal Blocks*

The **Wiring Diagram** tab shows the terminal assignments and the electrical circuits for the safety and non-safety inputs, Safety Outputs, and status outputs, and any terminals that are still available for the selected module. Use the wiring diagram as a guide to physically connect the devices. Navigate between modules using the Page Navigation toolbar at the top right corner of the Software.

## 8.9 Ladder Logic Tab

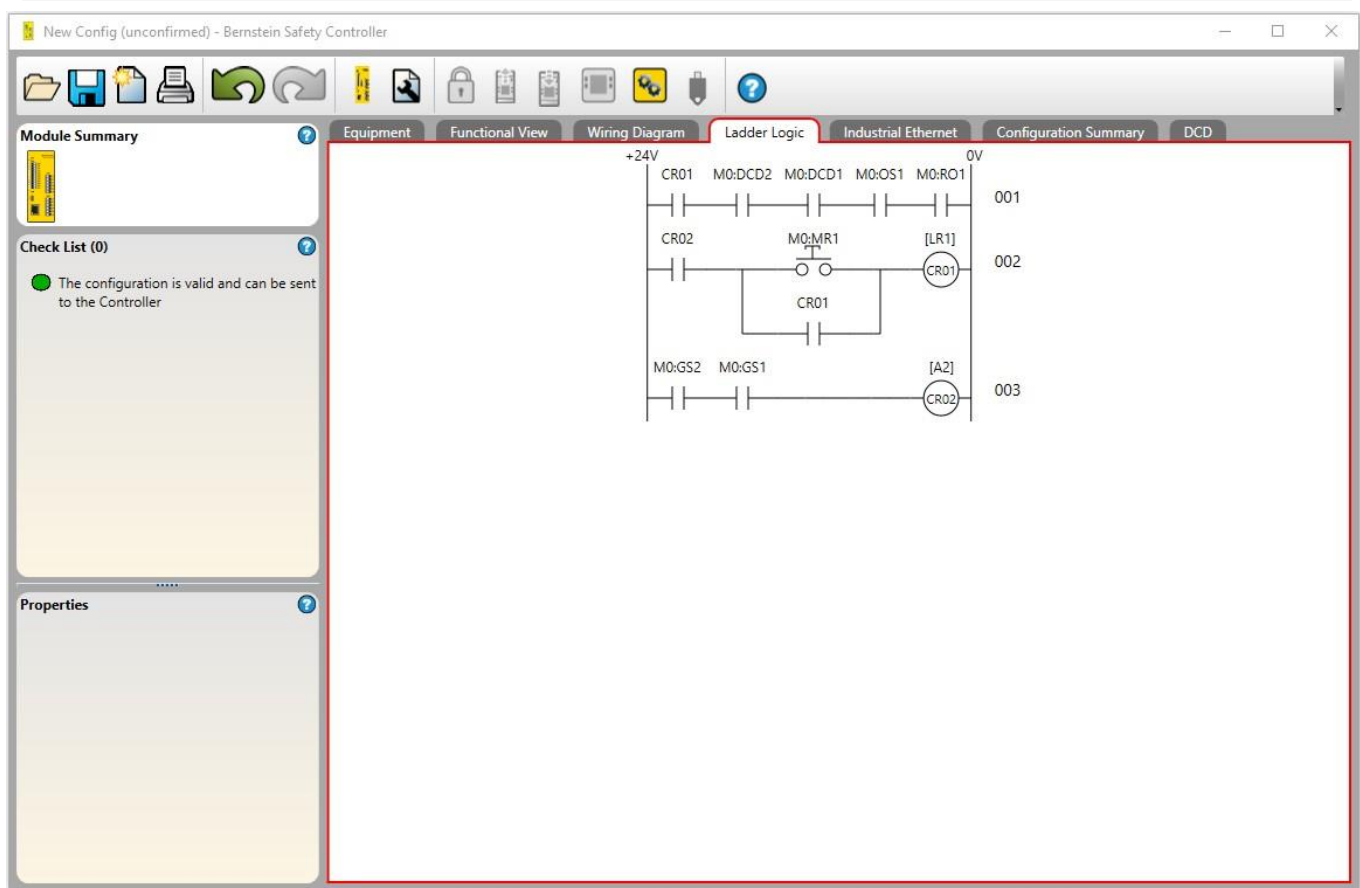

Figure 72: Ladder Logic Tab

The **Ladder Logic** tab displays a simplified relay logic rendering of the configuration.



## 8.10 DCD Tab

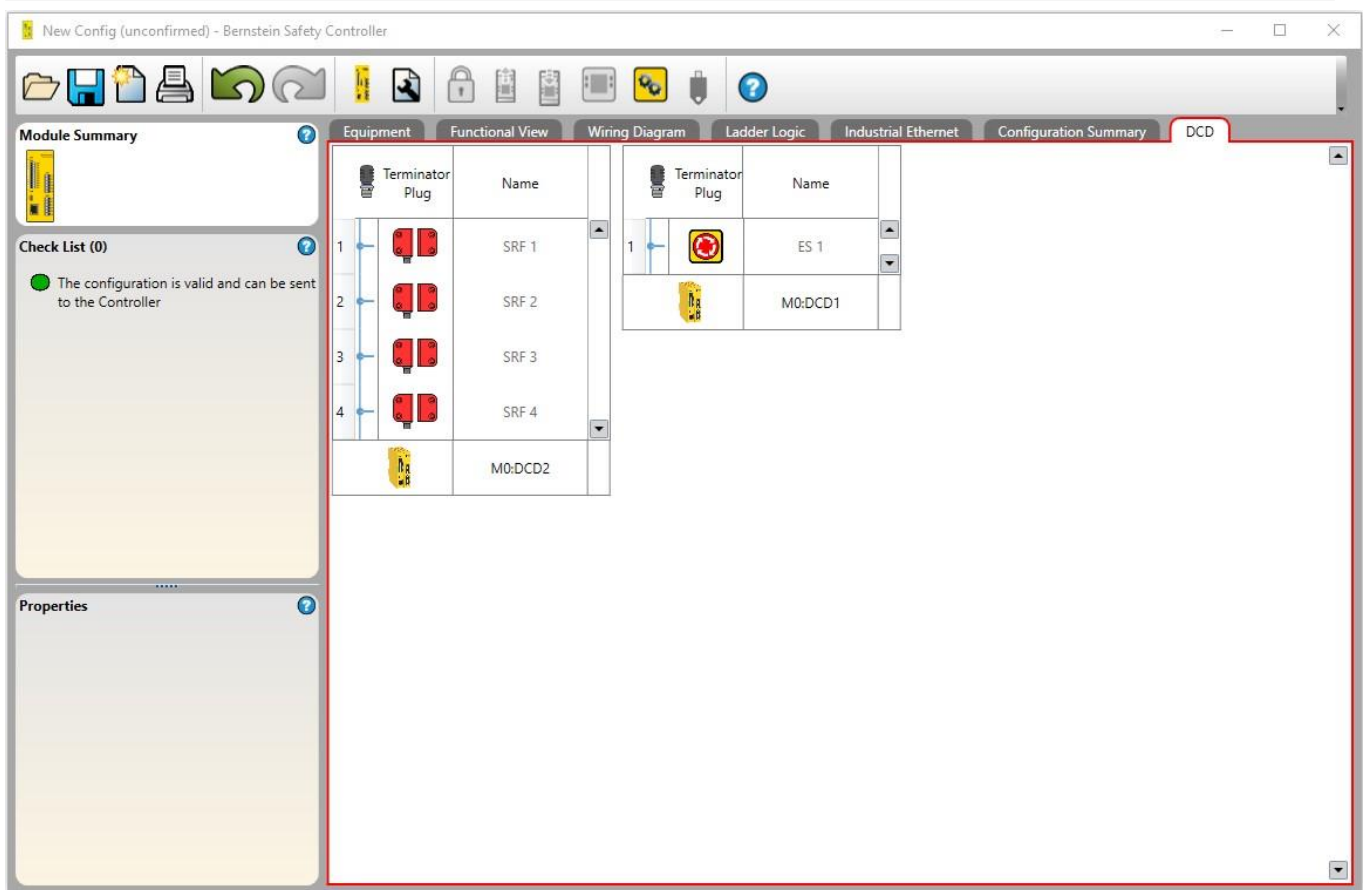

Figure 73: DCD Tab

The **DCD** tab shows the order and device names of the connected DCD devices in each DCD chain.

In Live Mode, the **DCD** tab displays real-time information (updated approximately once per second) about the connected devices. In the following example, a gate switch is open, as shown by the red indicator, or Off status, and the blank indicator under Actuator.

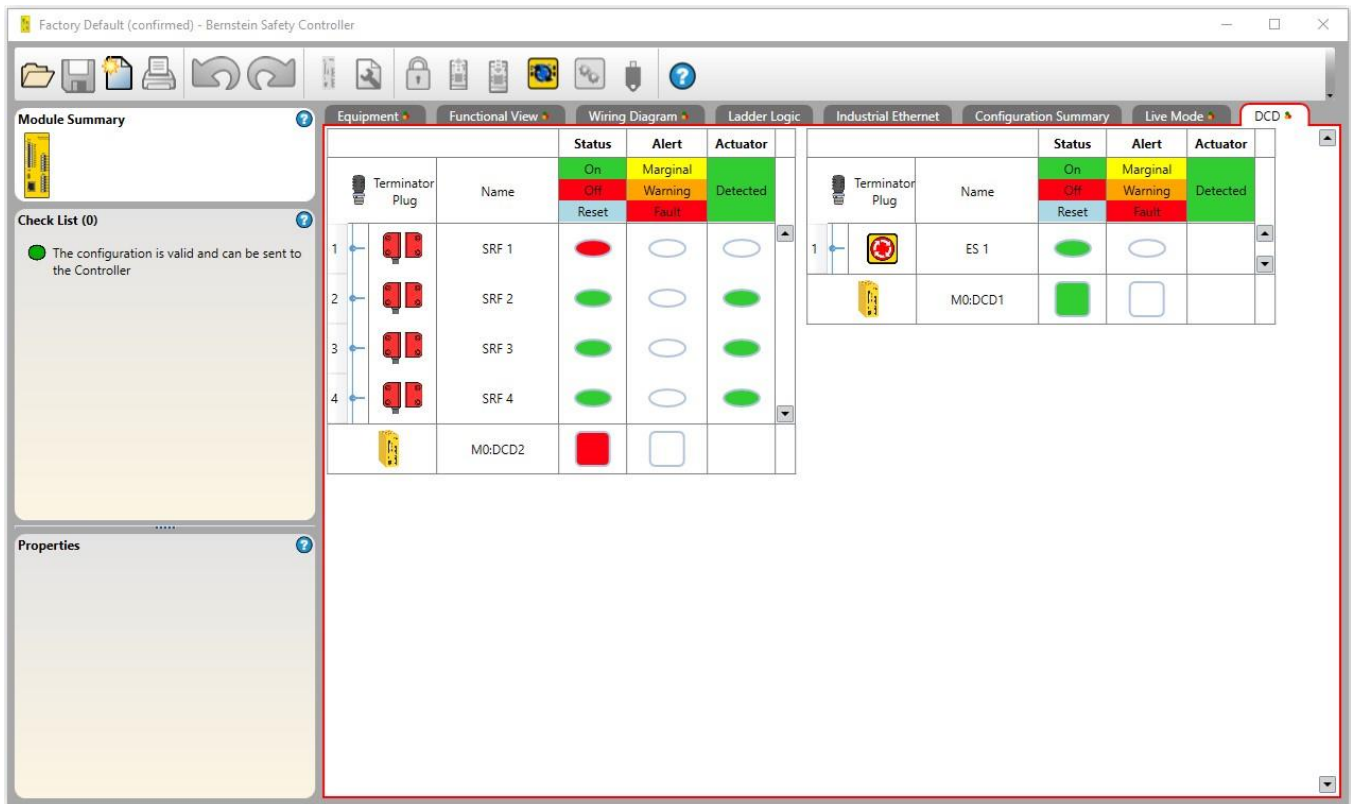

Figure 74: DCD Tab in Live Mode with a Switch Open

In Live Mode, click on a device to view diagnostic data about that device. The data includes output, input, and whether the actuator is detected.

The screenshot shows the Bernstein Safety Controller software interface in Live Mode, specifically the DCD (Diagnostic Data) tab. The interface is divided into several sections:

- Top Menu Bar:** Includes options for Equipment, Functional View, Wiring Diagram, Ladder Logic, Industrial Ethernet, Configuration Summary, Live Mode, and DCD.
- Left Sidebar:**
  - Module Summary:** Shows a small icon of the controller.
  - Check List (0):** A green circle indicates "The configuration is valid and can be sent to the Controller".
  - Properties:** A section for viewing component properties.
- Central Table:** Displays diagnostic data for various components. It has columns for Terminator Plug, Name, Status, Alert, and Actuator.
 

Terminator Plug	Name	Status	Alert	Actuator
1	SRF 1	On	Marginal	Detected
2	SRF 2	Off	Warning	Detected
3	SRF 3	Reset	Fault	Detected
4	SRF 4	On	Marginal	Detected
	M0:DCD2	On	Marginal	Detected
- Right Sidebar:** Shows diagnostic data for "Chain: 1 Device: 1". It lists various parameters and their values.
 

Chain: 1	Device: 1
Output 1	False
Output 2	False
Actuator Detected	False
Wrong Actuator	False
Marginal Range	False
Input 1	True
Input 2	True
Local Reset Expected	False
Output Error	False
Safety Input Fault	False
DCD Data Error	False
Operating Voltage Error	False
Power Cycle Required	False
Operating Voltage Warning	False
Sensor Not Paired	False
Device	Door Switch
Expected Code	1234
Received Code	0000
Teach-ins Remaining	0
Number of Voltage Errors	0000
Output Switch-off Time	Inactive
Range Warning Count	0000
Supply Voltage	24.0 V
Internal Temperature	31 C
Actuator Distance	> 18 mm
Expected Company Name	0005
Received Company Name	0000
Internal Error A	0000
Internal Error B	0000
Local Reset Unit	False
High Coding Level	False
Cascadable	True
Fault Tolerant Outputs	True

Figure 75: DCD Tab in Live Mode with Diagnostic Data

## 8.11 Industrial Ethernet Tab

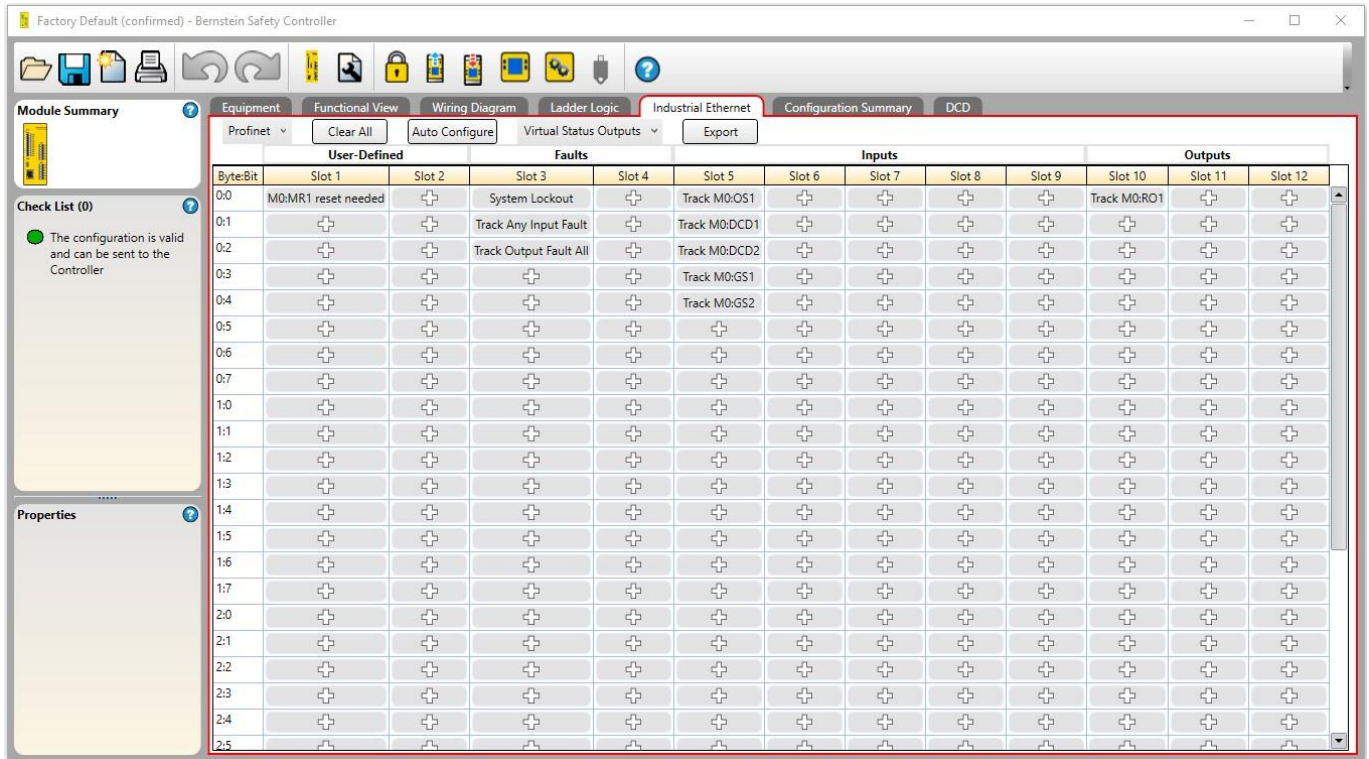

Figure 76: Industrial Ethernet Tab

The **Industrial Ethernet** tab of the Software allows configuration of the Virtual Status Outputs, which offer the same functionality as **Status Outputs** (added on the **Equipment** tab) over the network (see [Status Output Signal Conventions](#) on p. 50 and [Status Output Functionality](#) on p. 50 for detailed information). Up to 64 Virtual Status Outputs can be added for any configuration using Modbus/TCP, EtherNet/IP Input Assemblies, EtherNet/IP Explicit Messages, and PCCC protocols on FID 1 Base Controllers and up to 256 Virtual Status Outputs can be added on FID 2 or later Base Controllers and SCR P-2 Safety Controllers. FID 2 or later Base Controllers and SCR P-2 Safety Controllers can also use PROFINET.

To access the **Industrial Ethernet** tab:

1. Click **Network Settings**.
2. Select **Enable Network Interface**.
3. Adjust any settings, if necessary. See [Network Settings: Modbus/TCP, Ethernet/IP, PCCC](#) on p. 93 or [Network Settings: PROFINET](#) on p. 94.
4. Click **OK**.

Use the **Auto Configure** function, located on the **Industrial Ethernet** tab of the Software, to automatically configure the

Virtual Status Outputs to a set of commonly used functions, based on the current configuration. Click **+** in the **Function** column next to any of the **VOx** cells to add a Virtual Status Output manually. Functions of all Virtual Status Outputs can be modified by clicking on the button that contains the name of the function of the Virtual Status Output or by clicking **Edit** under the **Properties** table when VOx is selected.

## Network Settings



### Network Settings: Modbus/TCP, Ethernet/IP, PCCC

Figure 77: Network Settings

Click **Network Settings** on the Software to open the **Network Settings** window. In the case of a Modbus/TCP connection, the default TCP port used is 502, by specification. This value is not shown in the **Network Settings** window.

Table 7: Default Network Settings

Setting Name	Factory Default Value
<b>IP Address</b>	192.168.0.128
<b>Subnet Mask</b>	255.255.255.0
<b>Gateway Address</b>	0.0.0.0
<b>Link Speed and Duplex Mode</b>	Auto Negotiate

An **Actuation Code** is required for configurations containing a virtual manual reset or cancel delay input.

The **Advanced** option allows further configuration of Modbus/TCP and EtherNet/IP settings, such as Swap character bytes, MSW and LSW sending precedence, and String Length Type (EtherNet/IP and PCCC).

Click **Send** to write the network settings to the Safety Controller. Network settings are sent separately from the configuration settings.

Click **Network Timeout Enabled** to have any configured Virtual On/Off or Virtual Mute Enable become inactive in the event of a network timeout condition. The network timeout time is fixed at 5 seconds.



**Note:** Use **Password Manager** to enable or disable the ability for User2 and User3 to change the network settings.



## Network Settings: PROFINET

After selecting the PROFINET protocol on the **Industrial Ethernet** tab, click  **Network Settings** on the Software to open the **Network Settings** window.

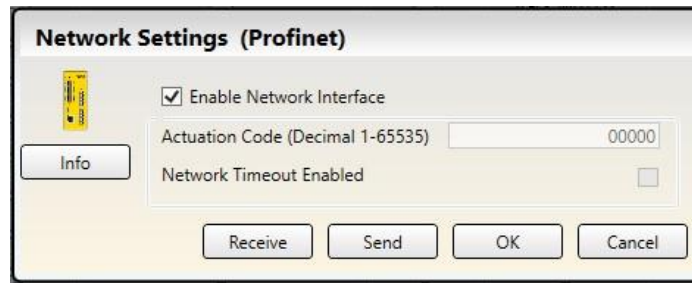

Figure 78: Network Settings—PROFINET

Click **Send** to write the network settings to the Safety Controller. Network settings are sent separately from the configuration settings.

Click **Network Timeout Enabled** to have all configured Virtual On/Off or Virtual Mute Enable become inactive in the event of a network timeout condition. The network timeout time is fixed at 5 seconds.



**Note:** Use **Password Manager** to enable or disable the ability for User2 and User3 to change the network settings.

## SCR P: PLC Tags/Labels File Creation

Use the BERNSTEIN Safety Controller Software to generate a .csv or .xml file that contains the names of all the virtual status outputs and inputs.

To use the names created in the BERNSTEIN Safety Controller software as the PLC Tags/Labels, import the .csv or .xml file into the PLC software for PLCs using Ethernet/IP Assemblies or PROFINET.

First, create all of the status outputs and inputs that are desired in the BERNSTEIN Safety Controller Software. Assign an actuation code under **Network Settings**, if needed. Then, make sure that the desired protocol is selected (either Ethernet/IP Assemblies or PROFINET).

## SCR P: Create a CSV File for Ethernet/IP Assemblies

Two items must be known:

- The name assigned to the Safety Controller in the PLC. This is needed to generate the file to import into the Ethernet/IP Assembly's PLC software
- Which input and output assembly instances are going to be requested

1. On the **Industrial Ethernet** tab, make sure **Ethernet/IP Assemblies** is selected from the list at the left.
2. Click **Export**.

The **Export to CSV** window opens.

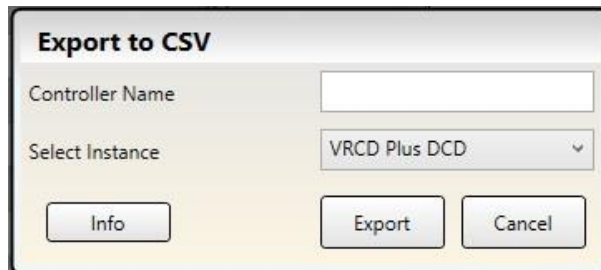

Figure 79: Export to CSV

3. In the **Controller Name** field, enter the name assigned to the Safety Controller in the PLC software.
4. Select the desired instance in the **Select Instance** list.

Which instance to select is based on what instances are being requested:

Instance Name	Output Assembly	Input Assembly
Status/Fault	112	100

Instance Name	Output Assembly	Input Assembly
Fault Index Words	112	101
Reset/Cancel Delay	112	103
VI Status/Faults	113	100
VI Fault Index Words	113	101
VI Reset/Cancel Delay	113	103
VRCD Plus DCD	114	104

If any virtual inputs (VI) are being used, the PLC's output assembly must be set to 113 or 114. This is so that the PLC can send the virtual input words to the Safety Controller. If information on the DCD inputs is desired with SCR P FID 2 or later controllers, an output assembly of 114 must be used to send virtual inputs (if used) and the extra words to request the DCD information (VRCD—virtual reset/cancel delay).

5. Click **Export**.
6. Save the .csv file in the desired location.

The .csv file is ready to be directly imported into the Ethernet/IP Assembly PLC software or the file can be opened with any software that can read a .csv file (for example, Microsoft Excel).

## SCR P: Create an XML File For PROFINET

Three items must be known:

- The name assigned to the Safety Controller in the PLC. This is needed to generate the file to import into the PROFINET PLC software
- PLC Slot 1 address location
- PLC Slot 13 address location
- PLC Slot 20 address location
- PLC Slot 21 address location

1. On the **Industrial Ethernet** tab, make sure **Profinet** is selected from the list at the left.
2. Click **Export**.

The **Export to Excel** window opens.

Figure 80: Export to Excel

3. In the **Controller Name** field, enter the name assigned to the Safety Controller in the PLC software.
4. In the **PLC Slot 1 Address Location** field, enter the beginning address location of slot 1 (status outputs).
5. In the **PLC Slot 13 Address Location** field, enter the beginning address location of slot 13 (virtual inputs).
6. In the **PLC Slot 20 Address Location** field, enter the beginning address location of slot 20 (DCD Status Information Module).
7. In the **PLC Slot 21 Address Location** field, enter the beginning address location of slot 21 (DCD Individual Device Information Module).
8. Click **Export**.
9. Save the .xml file to the desired location.

The .xml file is ready to be directly imported into the PROFINET PLC software or the file can be opened with any software that can read a .xml file (for example, Microsoft Excel).

## EtherNet/IP Assembly Objects



**Note:** The EDS file is available for download at [www.bernstein.eu](http://www.bernstein.eu). For additional information, see [Industrial Ethernet Overview](#) on p. 109.

### Input (T->O) Assembly Objects

Instance ID	Data Length (16-bit words)	Description
100 (0x64)	8	Used to access the basic information about the Virtual Status Outputs 1–64.
101 (0x65)	104	Used to access the advanced information (including the basic information) about the Virtual Status Outputs.
102 (0x66)	150	Used to access the fault log information and provides no Virtual Status Output information.
103 (0x67)	35	Used to access the basic information about Virtual Status Outputs 1–256 and feedback information about Virtual Reset and Virtual Cancel Delay inputs. Available on SCR P.
104 (0x68)	112	Used to access the basic information about Virtual Status Outputs 1–256, feedback information about Virtual Reset and Virtual Cancel Delay inputs, and to support communications with DCD-enabled devices.

### Output (O->T) Assembly Object

Instance ID	Data Length (16-bit words)	Description
112 (0x70)	2	<i>Reserved</i>
113 (0x71)	11	Used to control Virtual Inputs (On/Off, Mute Enable, Reset, Cancel Delay). Available on SCR P.
114 (0x72)	14	Used to control Virtual Inputs (On/Off, Mute Enable, Reset, Cancel Delay) and to support communications with DCD-enabled devices.

### Configuration Assembly Object

The Configuration Assembly Object is not implemented. However, some EtherNet/IP clients require one. If this is the case, use Instance ID 128 (0x80) with a data length of 0.

Set the Data Type of the communication format to INT.

Set the RPI (requested packet interval) to a minimum of 150.



## 8.12 Configuration Summary Tab

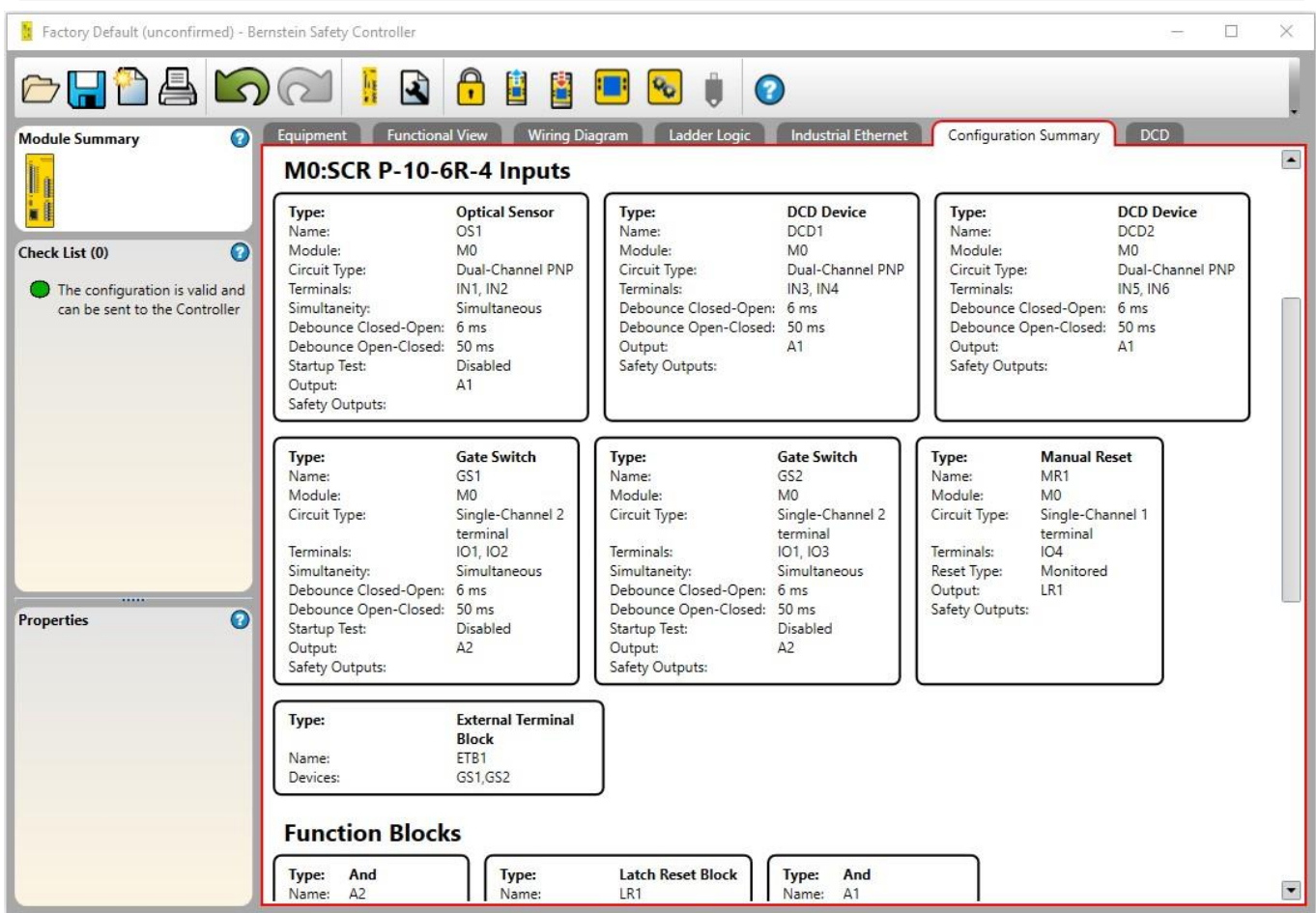

Figure 81: Configuration Summary Tab

The **Configuration Summary** tab displays the detailed information about all configured inputs, Function and Logic Blocks, Safety Outputs, Status Outputs, and the related Response Times in a text format.

## 8.13 Print Options

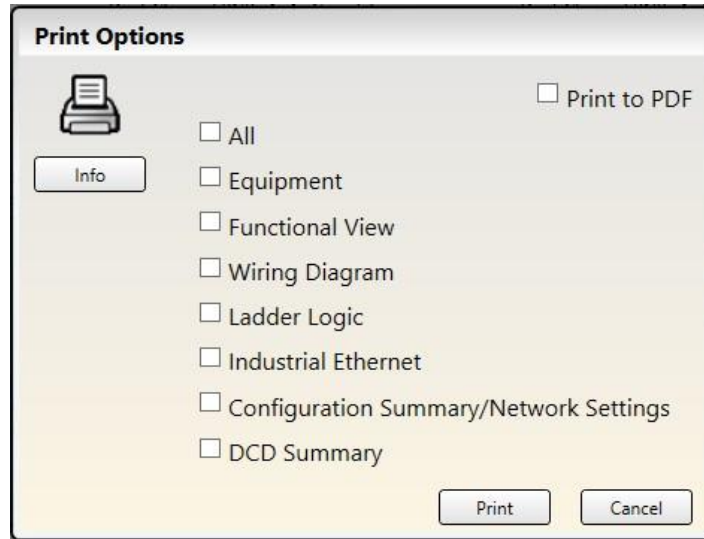

Figure 82: Print Options

The Software provides several options to print the configuration. Click **Print** on the toolbar to access the **Print Options** window.

The following print choices are available:

- 1 **All**—Prints all views, including **Network Settings** (in Ethernet-enabled versions)
- 2 **Equipment**—Prints the **Equipment** tab
- 3 **Functional View**—Prints the **Functional View** tab
- 4 **Wiring Diagram**—Prints the **Wiring Diagram** tab
- 5 **Ladder Logic**—Prints the **Ladder Logic** tab
- 6 **Industrial Ethernet**—Prints the **Industrial Ethernet** tab
- 7 **Configuration Summary/Network Settings**—Prints the **Configuration Summary** and **Network Settings** (when available)
- 8 **DCD Summary**—Prints the **DCD** tab
- 9 Printing Options:
- 10 **Print to PDF**—Prints the selection to a PDF file stored in a user-defined location
- 11 **Print**—Opens the default Windows Print dialog and sends the selection to the user-defined printer

## 8.14 SCR P Password Manager

**Password Manager** is available when a Safety Controller is connected to the PC via USB. The information shown in **Password Manager** comes from the Safety Controller.



Figure 83: SCR P Password Manager

Click  **Password Manager** on the Software toolbar to edit the configuration access rights. The Safety Controller stores up to three user passwords to manage different levels of access to the configuration settings. The password for User1 provides full read/write access and the ability to set access levels for User2 and User3 (user names cannot be changed). The configuration, network settings, wiring diagrams, and diagnostic information are accessible without a password. A configuration stored on a PC or an SCR P-FPS drive is not password-protected.

User2 or User3 can write the configuration to the Safety Controller when **Allowed to change the configuration** is enabled. They can change the network settings when **Allowed to change the network settings** is enabled. Their respective passwords will be required.

Click **Save** to apply the password information to the current configuration in the Software and to write the password information to the Safety Controller.



**Note:** The default passwords for User1, User2, and User3, are 1901, 1902, and 1903, respectively. It is highly recommended to change the default passwords to new values.

Only User1 can reset the SCR P back to the factory defaults.

## 8.15 Viewing and Importing Controller Data

The BERNSTEIN Safety Controller Software allows viewing or copying current Safety Controller data, such as model number and firmware version, configuration and network settings, and the wiring diagram.



**Read from Controller** is available when a Safety Controller is connected to the PC via USB.

### Viewing System and Network Settings Snapshot

Click  **Read from Controller** on the Software toolbar. The current Safety Controller settings are displayed:

- Configuration Name
- Configuration CRC
- Date Confirmed
- Time confirmed
- Author
- Project Name
- IP Address
- Subnet mask
- Gateway address
- Link speed and duplex mode
- MAC ID

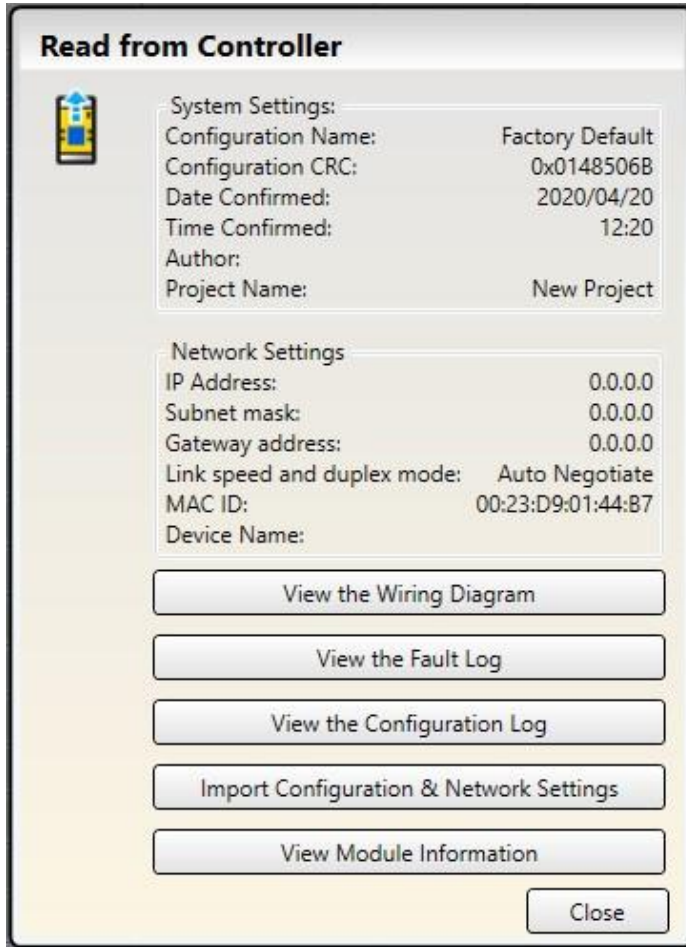

Figure 84: Viewing System and Network Settings

### Viewing and Importing Controller Data

Click  **Read from Controller** to view:

- **Wiring Diagram**—Removes all other tabs and worksheets from the Software and displays only **Wiring Diagram** and **Equipment** tabs
- **Fault Log**—History of the last 10 faults



**Note:** Fault Log numbering increases up to 4,294,967,295 unless the Safety Controller power cycle is performed, in which case the numbering is reset to start at 1. Clearing the Fault Log (either via the Software or the onboard interface) removes the log history but retains the numbering.

- **Configuration Log**—History of up to 10 most recent configurations (only the current configuration can be viewed or imported)
- **Module Information**

Click **Import Configuration & Network Settings** to access the current Safety Controller configuration and network settings (depends on user access rights, see or [SCR P Password Manager](#) on p. 99).

## 8.16 Live Mode

**Live Mode** is available when a Safety Controller is connected to the PC via USB.

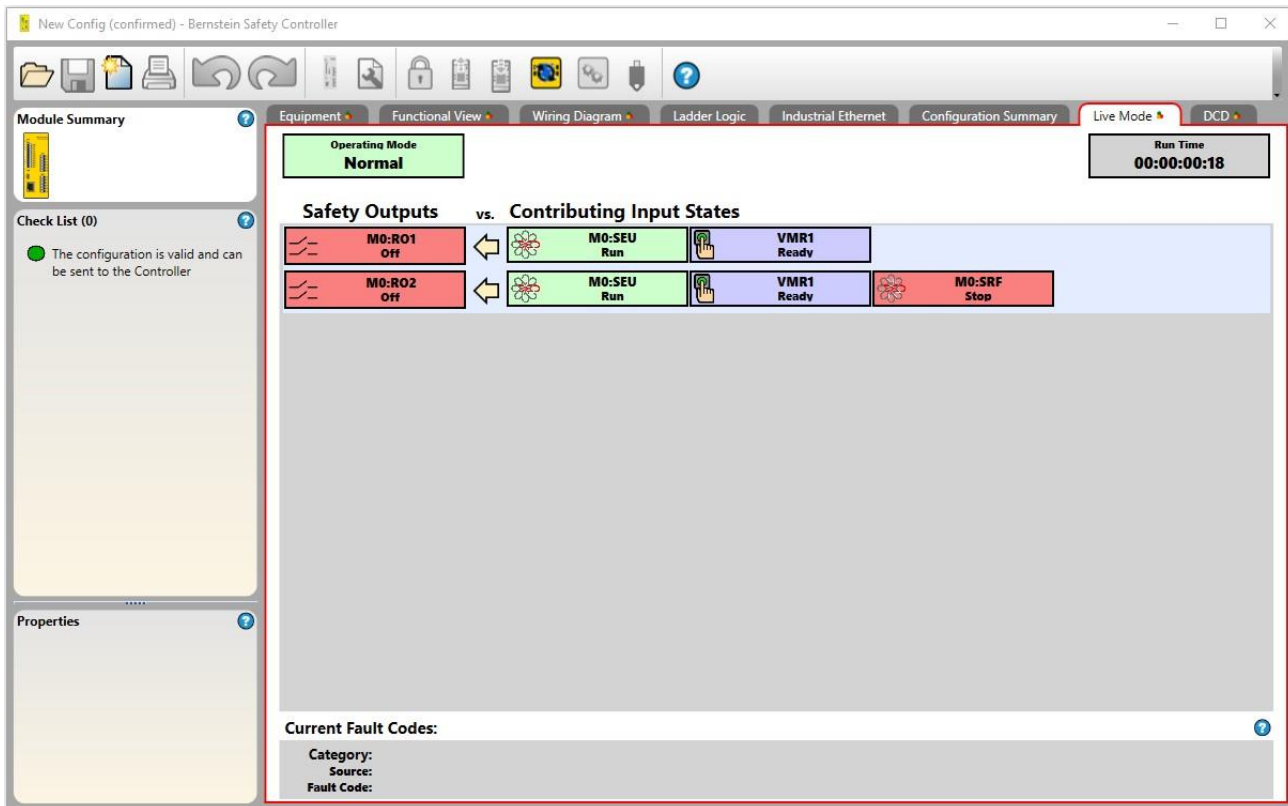



Figure 85: Run Time—Live Mode Tab

The **Live Mode** tab becomes accessible when  **Live Mode** is clicked on the toolbar. Enabling **Live Mode** disables configuration modification on all other tabs. The **Live Mode** tab provides additional device and fault information, including a fault code (see [SCR P Fault Code Table](#) on p. 188 for the description and possible remedies). The Run-time data is also updated on the **Functional View**, **Equipment**, and **Wiring Diagram** tabs providing the visual representation of the device states.

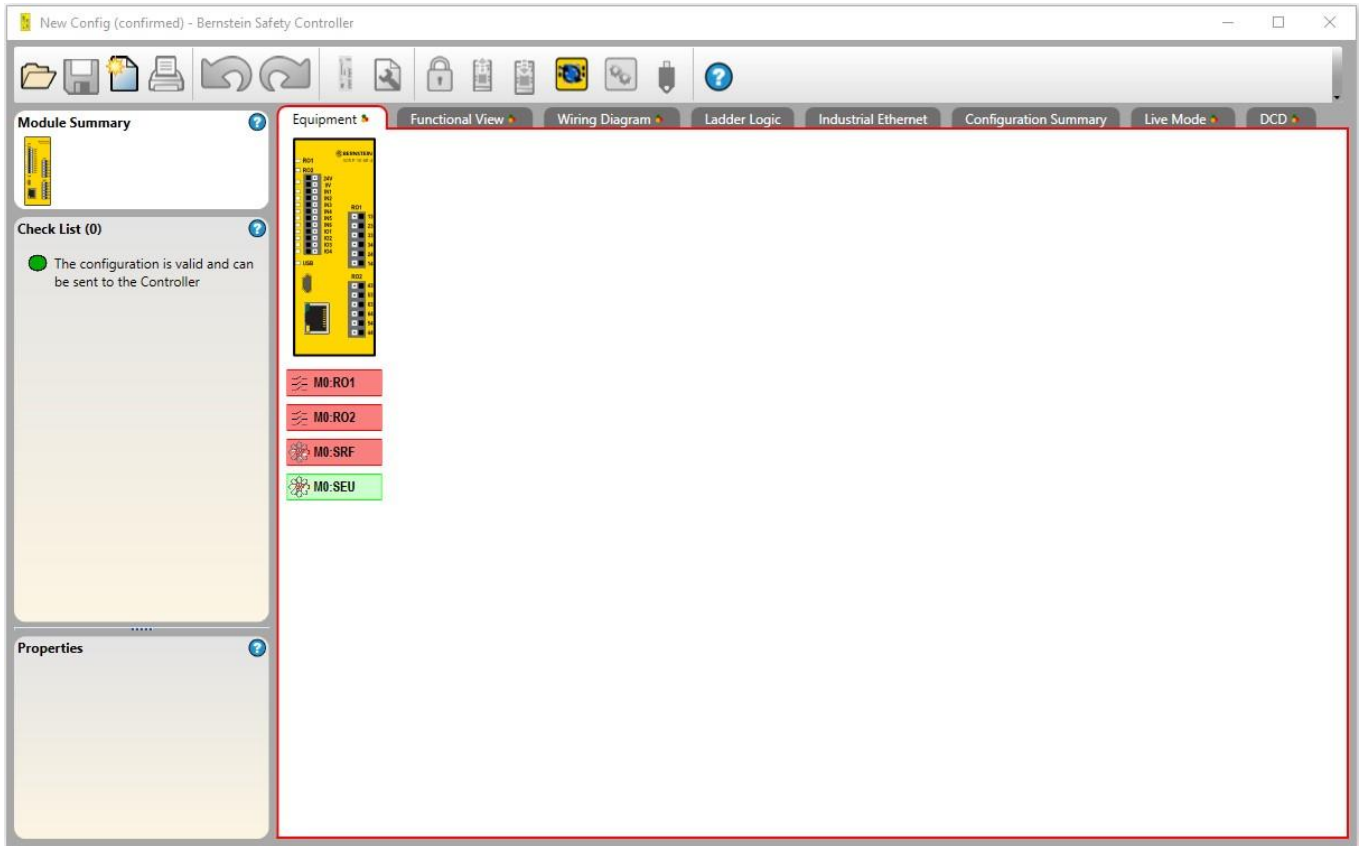

Figure 86: Run Time—Equipment Tab

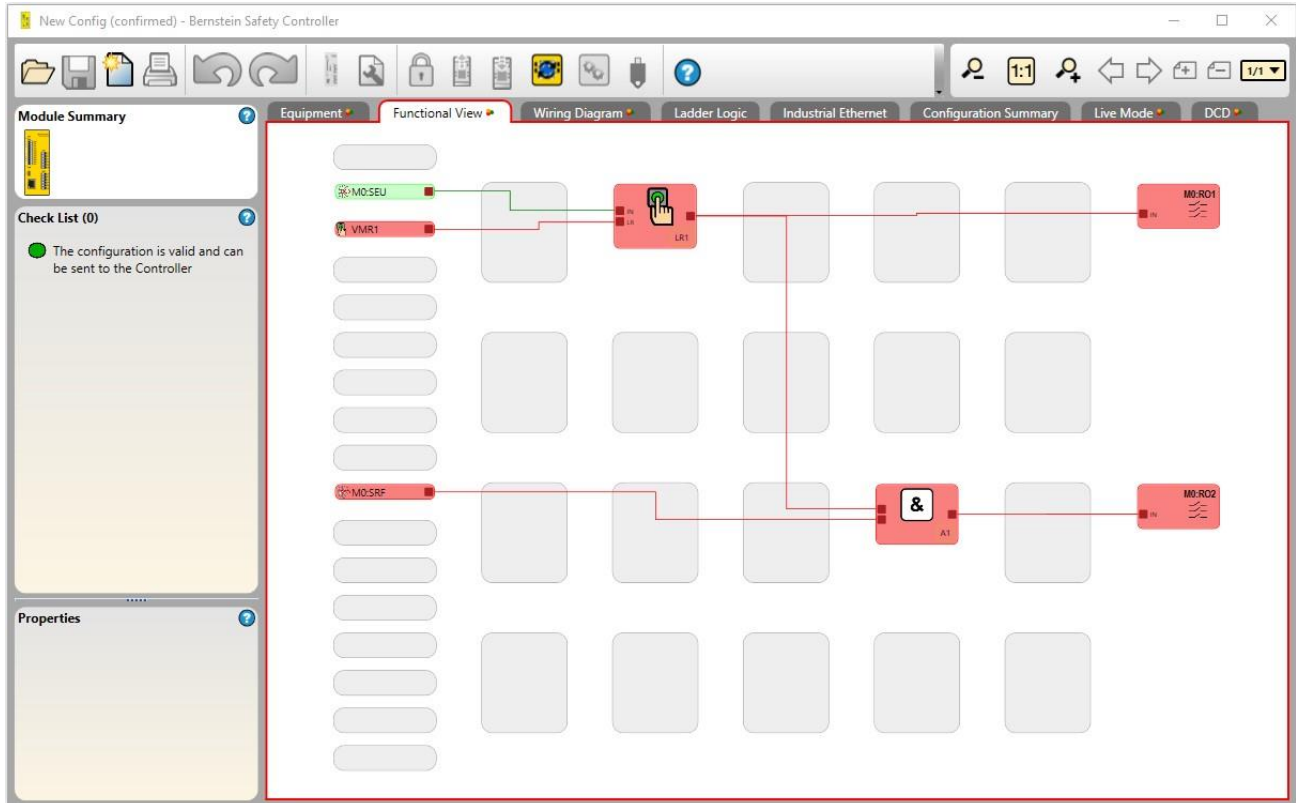

Figure 87: Run Time—Functional View Tab

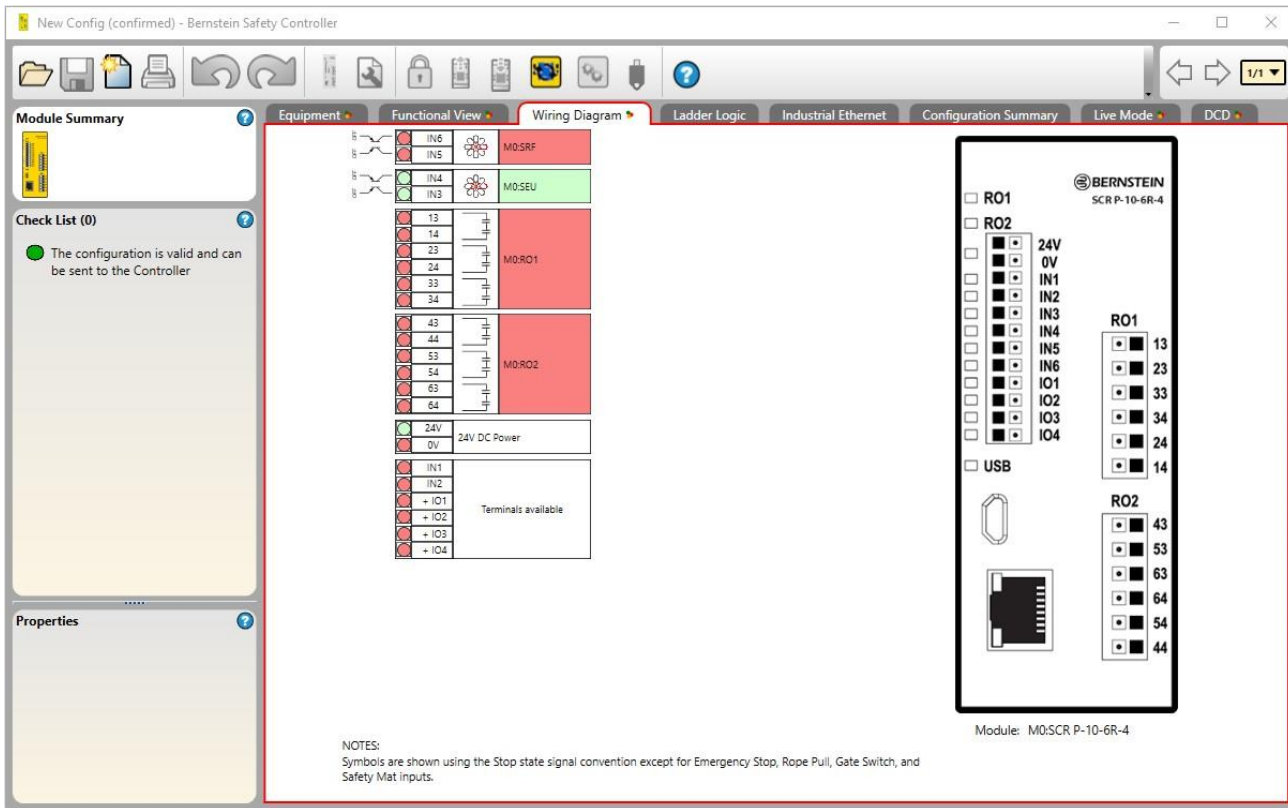

Figure 88: Run Time—Wiring Diagram Tab

Module Summary

Check List (0)

The configuration is valid and can be sent to the Controller

Properties

Equipment Functional View Wiring Diagram Ladder Logic Industrial Ethernet Configuration Summary Live Mode DCD

Terminator Plug	Name	Status	Alert	Actuator
1	SRF 1	On	Marginal	Detected
2	SRF 2	Off	Warning	
3	SRF 3	Reset	Fault	
4	SRF 4			
	M0:SRF			

Terminator Plug	Name	Status	Alert	Actuator
1	ES 1	On	Marginal	Detected
	M0:SEU			

Chain: 1 Device: 1

Output 1	False
Output 2	False
Actuator Detected	False
Wrong Actuator	False
Marginal Range	False
Input 1	True
Input 2	True
Local Reset Expected	False
Output Error	False
Safety Input Fault	False
DCD Data Error	False
Operating Voltage Error	False
Power Cycle Required	False
Operating Voltage Warning	False
Sensor Not Paired	False
Device	Door Switch
Expected Code	1234
Received Code	0000
Teach-ins Remaining	0
Number of Voltage Errors	0000
Output Switch-off Time	Inactive
Range Warning Count	0000
Supply Voltage	24.0 V
Internal Temperature	39 C
Actuator Distance	>18 mm
Expected Company Name	0005
Received Company Name	0000
Internal Error A	0000
Internal Error B	0000
Local Reset Unit	False
High Coding Level	False
Cascadable	True
Fault Tolerant Outputs	True

Figure 89: Run Time—DCD Tab

## 8.17 Simulation Mode

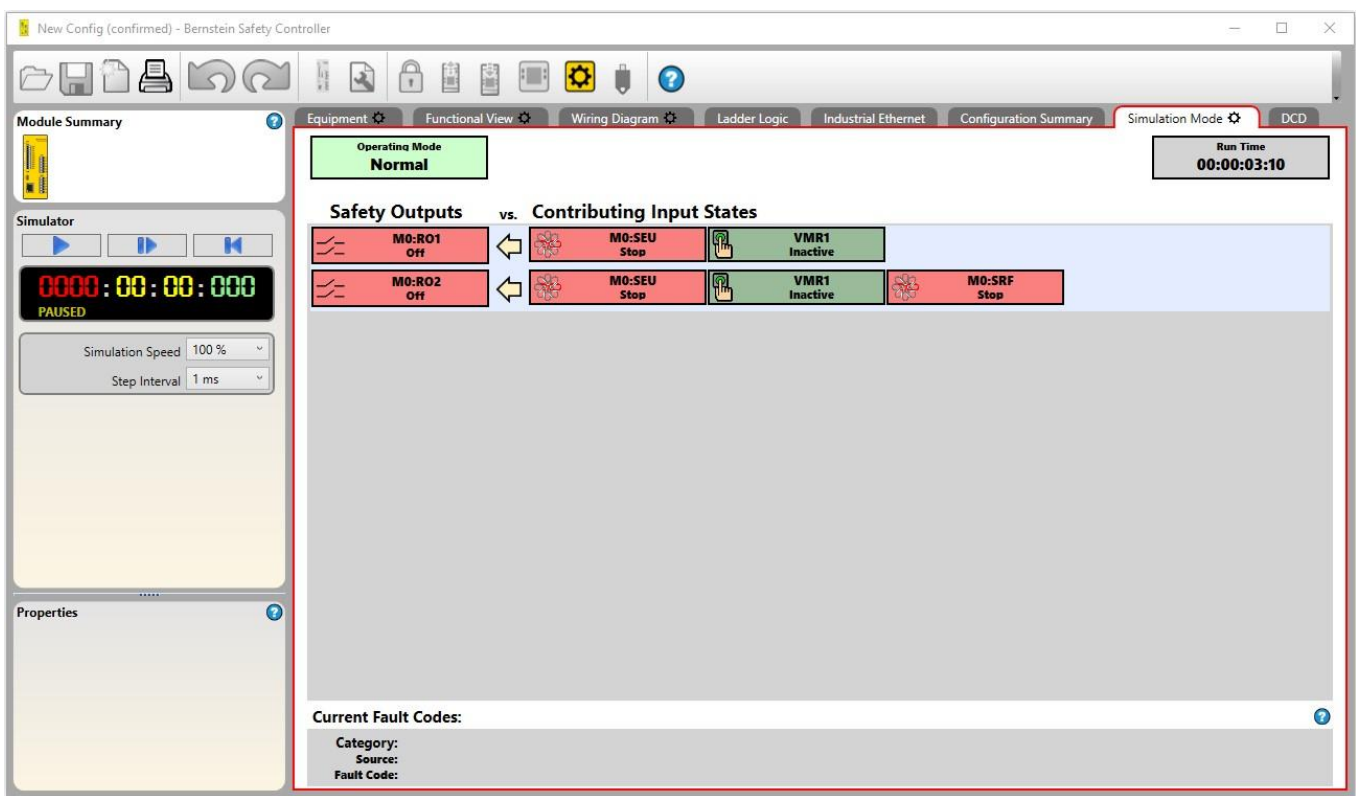



Figure 90: Simulation Mode

The **Simulation Mode** tab becomes accessible when  **Simulation Mode** is clicked on the toolbar. Simulation Mode options become available on the left side of the screen. The **Simulation Mode** tab contains view only information; you cannot click on the output or input items in this view.



**Note:** For DCD inputs, individual devices are not simulated, only the final output that is connected to the SCR P input terminals is simulated (on or off).



[Play/Pause] Starts the simulation time running at the specified simulation speed or temporarily stops the simulation time.



[Single Step] Advances the simulation time at the specified step interval.



[Reset] Resets the timer to zero and the equipment to the initial stop state.

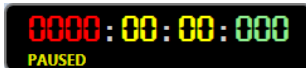

[Timer] Displays elapsed time in hours, minutes, seconds, and thousandths of a second.

**Simulation Speed**—Sets the speed of the simulation.



- 1%
- 10%
- 100% (default speed)
- 500%
- 2,000%

**Step Interval**—Sets the amount of time that the Single Step button advances when pressed. The amount of time is based on the size of the configuration.

Press **Play** to begin the simulation. The timer runs and gears spin to indicate that the simulation is running. The **Functional**, **Equipment**, and **Wiring Diagram** tabs update, providing visual representation of the simulated device states as well as allowing testing of the configuration. Click on the items to be tested; their color and state change accordingly. Red indicates the stop or off state. Green indicates the run or on state. Yellow indicates a fault state. Orange indicates that the input was turned on before the initial start of the simulation. Due to a start-up off test requirement, the input must be seen as off before it can be recognized as on.

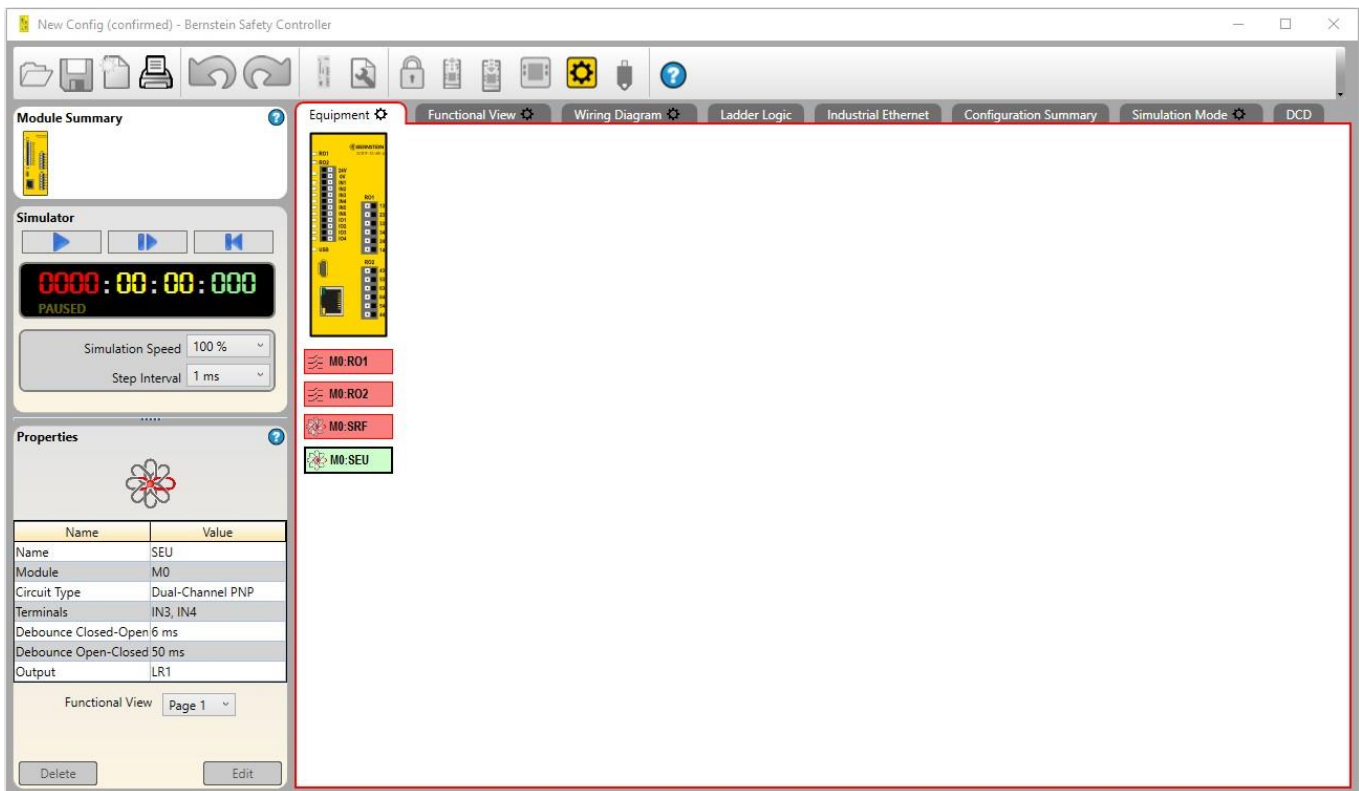

Figure 91: Simulation Mode—Equipment Tab

**Module Summary**

**Simulator**

0000:00:00:000  
PAUSED

Simulation Speed 100 %  
Step Interval 1 ms

**Properties**

Name	Value
Name	SEU
Module	M0
Circuit Type	Dual-Channel PNP
Terminals	IN3, IN4
Debounce Closed-Open	6 ms
Debounce Open-Closed	50 ms
Output	LR1

Functional View Page 1

Delete Edit

**Wiring Diagram**

Equipment Functional View Wiring Diagram Ladder Logic Industrial Ethernet Configuration Summary Simulation Mode DCD

IN6  
IN5  
IN4  
IN3

M0SRF  
M0SEU

13  
14  
23  
24  
33  
34

M0RO1

43  
44  
53  
54  
63  
64

M0RO2

24V  
0V  
24V DC Power

IN1  
IN2  
IO1  
IO2  
IO3  
IO4

Terminals available

**BERNSTEIN**  
SCR P-10-6R-4

RO1  
RO2

24V  
0V  
IN1  
IN2  
IN3  
IN4  
IN5  
IN6  
IO1  
IO2  
IO3  
IO4

RO1

13  
23  
33  
34  
24

RO2

43  
53  
63  
64  
54  
44

USB

Module: M0SCR P-10-6R-4

NOTES:  
Symbols are shown using the Stop state signal convention except for Emergency Stop, Rope Pull, Gate Switch, and Safety Mat inputs.

Figure 92: Simulation Mode—Wiring Diagram Tab

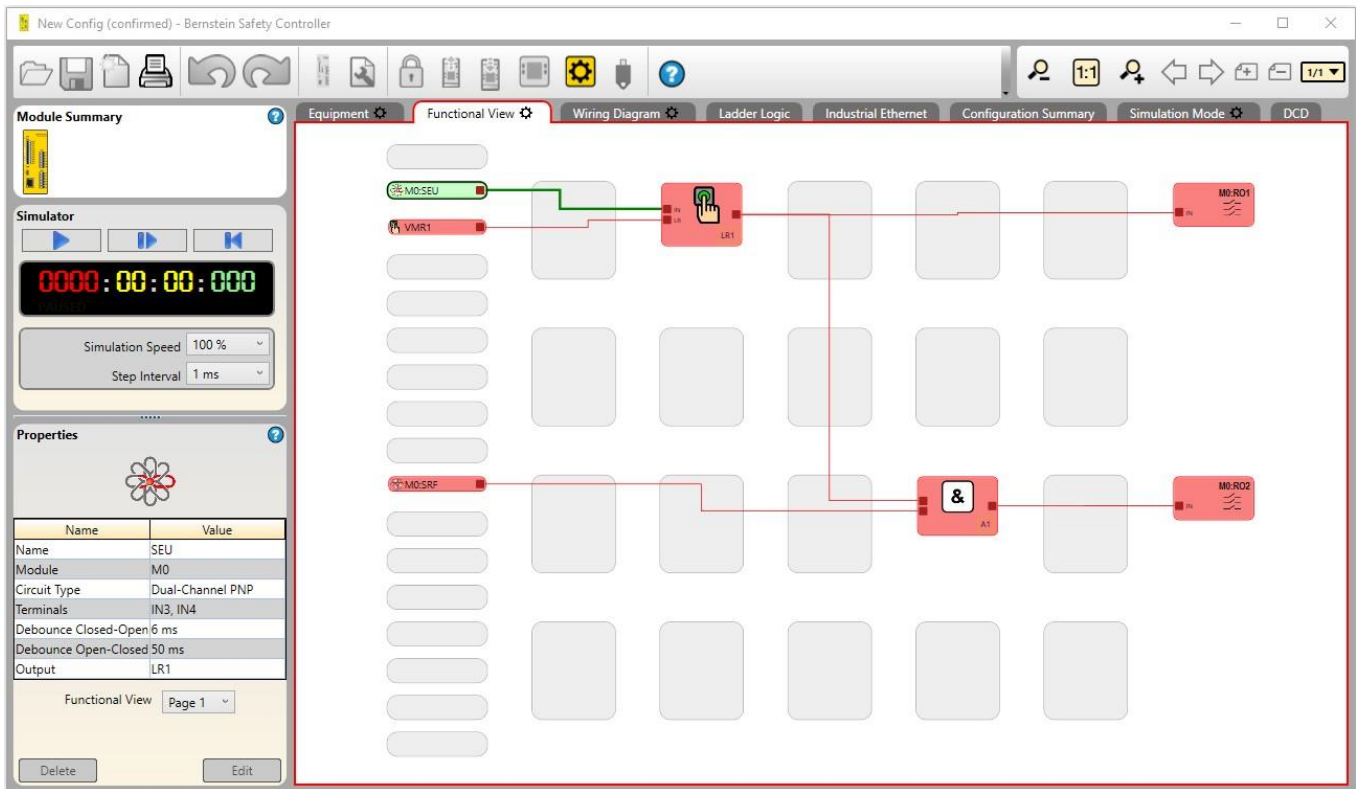

Figure 93: Simulation Mode—Functional View Tab

## Timed Action Mode

While in Simulation Mode and on the **Functional View** tab, certain elements which are in delay action modes are indicated in purple. The progress bar shows the countdown of the associated timer for that element.

The following figures show the different element states:



Figure 95: Safety output in Delay Off Timing mode

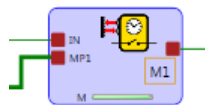

Figure 96: Muting Block in Timed Muting mode

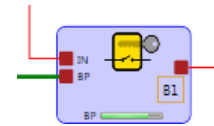

Figure 97: Bypass Block in Timed Bypass mode

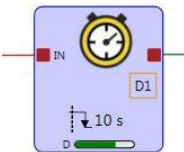

Figure 94: Delay Block

**Note:** The M next to the progress bar indicates Timer Muting.



## 8.18 Reference Signals



**Important:** The configuration software incorporates Reference Signals that represent the state of Safety Controller outputs, input devices and both Function and Logic Blocks. A Safety Output reference signal can be used to control another Safety Output. In this type of configuration, the physical On state of the controlling Safety Output is not known. If the Safety Output On state is critical for the application safety, an external feedback mechanism is required. Note that the safe state of this Safety Controller is when the outputs are turned Off. If it is critical that Safety Output 1 is On before Safety Output 2 turns On, then the device that is being controlled by the Safety Output 1 needs to be monitored to create an input signal that can be used to control Safety Output 2. The Safety Output 1 reference signal may not be adequate in this case.

Figure 98 on p. 108 shows how one Safety Output can control another Safety Output. When Manual Reset **M0:MR1** is pressed, it turns On Safety Output **M0:RO2**, which, in turn, turns On Safety Output **M0:RO1**.

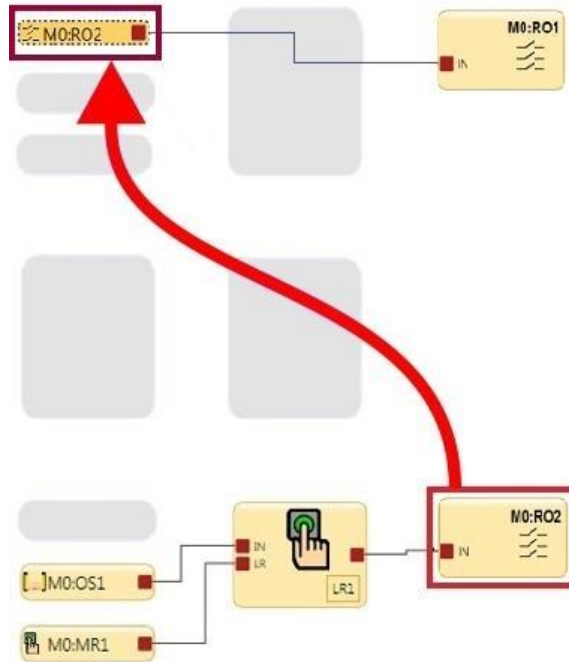



Figure 98: Safety Output controlled by another Safety Output

# 9 Industrial Ethernet Overview

## 9.1 Configuring the Safety Controller

Make sure that **Enable Network Interface** is selected, and the network settings are configured as needed by the chosen protocol.

1. Connect the Safety Controller to your PC via the USB cable to enable the port.
2. Open the BERNSTEIN Safety Controller Software.
3. Click  **Network Settings**.
4. Select the **Enable Network Interface** checkbox.
5. Configure the IP Address and Subnet Mask as needed for your network.



**Note:** If a Virtual Reset or Cancel Delay is used, an Actuation Code must be defined and then sent to the Safety Controller.

6. Click **Send**.
7. Click on the **Advanced** arrow to configure the Advanced network settings, if desired.  
The following are the default values for the Safety Controller's Ethernet port and Industrial Ethernet options.

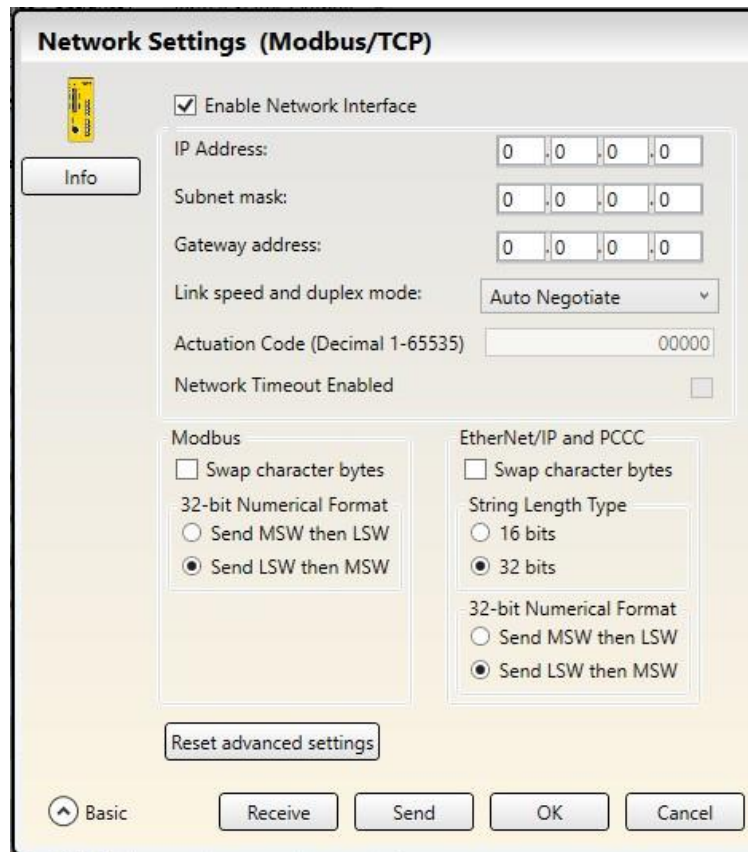

Figure 99: Default Values

8. Provide the appropriate password to change the configuration and network settings for the Safety Controller.
9. Make sure the Safety Controller has a valid and confirmed configuration file.

The Ethernet port is enabled.

## 9.2 Industrial Ethernet Definitions

The following are table row and column descriptions (listed in alphanumeric order) for the register maps found in the **Industrial Ethernet** tab of the Software.

Table 2: Data Types

Data Type	Description
<b>UINT</b>	Unsigned integer—16 bits
<b>UDINT</b>	Unsigned double integer—32 bits
<b>Word</b>	Bit string—16 bits
<b>Dword</b>	Bit string—32 bits
<b>String</b>	Two ASCII characters per Word (see protocol-based String information below)
<b>Octet</b>	Reads as each byte translated to decimal separated by a dot
<b>Hex</b>	Reads as each nibble translated to hex, paired, and then separated by a space
<b>Byte</b>	Bit string—8 bits

### Byte:Bit

Indicates the byte offset followed by the specific bit.

### Fault Flag

If the particular input or output being tracked causes a lockout, a flag associated with that virtual output will be set to 1. In Modbus/TCP, this can be read as a discrete input, input register, or holding register.

### Fault Index

If the Fault Flag bit is set for a virtual output, the Fault Index will contain a number, which translates to a Fault Code. For example, a Fault Index 41, can contain a number 201, which translates to the Fault Code 2.1; the number 412 would translate to the Fault Code 4.12 (see [SCR P Fault Code Table](#) on p. 188 for more information).

### Function

The function that determines the state of that virtual output.

### Operating Mode

Operating Mode Value	Description
1 (0x01)	Normal Operating Mode (including I/O faults, if present)
2 (0x02)	Configuration Mode
4 (0x04)	System Lockout
65 (0x41)	Waiting For System Reset/Exiting Configuration Mode
129 (0x81)	Entering Configuration Mode

### Reg:Bit

Indicates the offset from 30000 or 40000 followed by the specific bit in the register.

### Reserved

Registers that are reserved for internal use.

### Seconds Since boot

The time, in seconds, since power was applied to the Safety Controller. May be used in conjunction with the Timestamp in the Fault Log and a real time clock reference to establish the time when a fault occurred.

**String (EtherNet/IP and PCCC Protocol)**

The default format EtherNet/IP string format has a 32 bit length preceding the string (suitable for ControlLogix). When configuring the **Network Settings** using the Software, you can change this setting to a 16 bit length which corresponds to the standard CIP "String" under the **Advanced** menu. However, when reading an Input Assembly that includes a string with a 16 bit length, the string length will be preceded by an extra 16 bit word (0x0000).

The string itself is packed ASCII (2 characters per word). In some systems, the character order may appear reversed or out of order. For example, the word "System" may read out as "yStsme". Use "Swap character bytes" option under the **Advanced** menu in the **Network Settings** window to swap characters so words read correctly.

**String (Modbus/TCP Protocol)**

The string format is packed ASCII (2 characters per word). In some systems, the character order may appear reversed or out of order. For example, the word "System" may read out as "yStsme". Use "Swap character bytes" option under the **Advanced** menu in the **Network Settings** window to swap characters so words read correctly.

While the string length is provided, it is usually not required for Modbus/TCP systems. If string length is used for Modbus/TCP, the length format corresponds to the settings used for EtherNet/IP.

**Timestamp**

The time, in seconds, when the fault occurred since power up.

**Virtual Status Output**

The reference designator associated with a particular Virtual Status Output, for example, VO10 is Virtual Status Output 10.

**VO Status**

This identifies the location of a bit indicating the status of a Virtual Status Output. In the case of Modbus/TCP, the state of the Virtual Status Output can be read as a discrete input, as part of an input register, or holding register. The register given is the offset from 30000 or 40000 followed by the bit location within the register.

## 9.3 Retrieving Current Fault Information

Follow the steps below to retrieve information via network communications about a fault that currently exists:

1. Read the *Fault Index* location to retrieve the fault index value.
2. Find the index value in the [SCR P Fault Code Table](#) on p. 188 to access a fault description and steps to resolve the fault.

## 9.4 EtherNet/IP™

In this context, references to EtherNet/IP™<sup>11</sup> refer specifically to EtherNet/IP transport class 1. Sometimes referred to as cyclic EtherNet/IP IO data transfer or implicit messaging, this connection is meant to approximate a real-time data transfer to and from the PLC and the target device.

Allen-Bradley's CompactLogix and ControlLogix family of PLCs uses this communication protocol. The programming software used by these PLCs is RSLogix5000 or Studio 5000 Logix Designer.

### 9.4.1 Assembly Objects

#### Safety Controller Inputs (Outputs from PLC) O > T

The Safety Controller can use Instance 112 (0x70) with a size of two registers (16-bit) when sending virtual inputs 1–32 to the Safety Controller.

Table 3: PLC Output Assembly Instance 112 (0x70)—Safety Controller Inputs O > T

WORD #	WORD NAME	DATA TYPE
0	Virtual Input On/Off (1–16)	16-bit integer
1	Virtual Input On/Off (17–32)	16-bit integer

#### Safety Controller Inputs (Outputs from PLC) O > T

The Safety Controller uses Instance 113 (0x71)<sup>19</sup> with a size of eleven registers (16-bit) as its Input Assembly (PLC Output) when sending virtual inputs, resets, and cancel delays to the Safety Controller.

Table 4: PLC Output Assembly Instance 113 (0x71)—Safety Controller Inputs O > T

WORD #	WORD NAME	DATA TYPE
0	Virtual Input On/Off (1–16)	16-bit integer
1	Virtual Input On/Off (17–32)	16-bit integer
2	Virtual Input On/Off (33–48)	16-bit integer
3	Virtual Input On/Off (49–64)	16-bit integer
4	<i>reserved</i>	16-bit integer
5	<i>reserved</i>	16-bit integer
6	<i>reserved</i>	16-bit integer
7	<i>reserved</i>	16-bit integer
8	Virtual Reset/Cancel Delay (1–16) [RCD Register Bits] (see <a href="#">Virtual Manual Reset and Cancel Delay (RCD) Sequence</a> on p. 38)	16-bit integer
9	<i>reserved</i>	16-bit integer
10	RCD Actuation Code [RCD Enable Register] (see <a href="#">Virtual Manual Reset and Cancel Delay (RCD) Sequence</a> on p. 38)	16-bit integer

## Safety Controller Inputs (Outputs from the PLC) O > T

The Safety Controller uses Instance 114 (0x72) with a size of fourteen registers (16-bit) as its Input Assembly (PLC Output) when sending virtual inputs, resets, and cancel delays to the safety controller and for obtaining performance and status information about DCD devices.

Table 5: PLC Output Assembly Instance 114 (0x72)—Safety Controller Inputs O > T

WORD #	WORD NAME	DATA TYPE
0	Virtual Input On/Off (1–16)	16-bit integer
1	Virtual Input On/Off (17–32)	16-bit integer
2	Virtual Input On/Off (33–48)	16-bit integer
3	Virtual Input On/Off (49–64)	16-bit integer
4	<i>reserved</i>	16-bit integer
5	<i>reserved</i>	16-bit integer

<sup>19</sup> This eleven word assembly is called 112 (0x70) for FID 2 Safety Controllers with date codes before and including "1716". See [Which XS/SC26-2 EDS file and documentation should you use?](#) on p. 130 for more information.



WORD #	WORD NAME	DATA TYPE
6	<i>reserved</i>	16-bit integer
7	<i>reserved</i>	16-bit integer
8	Virtual Reset/Cancel Delay (1–16) [RCD Register Bits] (see <a href="#">Virtual Manual Reset and Cancel Delay (RCD) Sequence</a> on p. 38)	16-bit integer
9	<i>reserved</i>	16-bit integer
10	RCD Actuation Code [RCD Enable Register] (see <a href="#">Virtual Manual Reset and Cancel Delay (RCD) Sequence</a> on p. 38)	16-bit integer
11	DCD Read Request	16-bit integer
12	DCD Chain Requested	16-bit integer
13	DCD Device Requested	16-bit integer

## Request Performance and Status Information about an Individual Device via DCD

1. Write Word 12 to the correct DCD chain for the device in question (1 or 2).
2. Write Word 13 to the correct DCD device number (1 to 32).
3. Toggle word 11 from 0 to 1 to perform a one-time read.
4. Go to PLC Input Assembly Instance 104 (0x68), words 103–112 to read the device-specific data response.

## Safety Controller Configuration Assembly Object

The Safety Controller does not use a Configuration Assembly Object.

Because some EtherNet/IP clients require one, use Instance 128 (0x80) with a size of zero registers (16-bit).

## Safety Controller Outputs (Inputs to PLC) T > O

There are five choices for Safety Controller Output Assembly Objects.

The first and smallest choice includes information about Virtual Outputs and whether they have faults. The second choice adds advanced data such as the reason why each of the safety outputs is off, and more descriptive fault information for the Virtual Outputs. The third choice is used exclusively to access the Safety Controller's fault log. The fourth choice is used for the Virtual Manual Reset and Cancel Off Delay feedback. The fifth choice allows access to both Virtual Manual Reset and Cancel Delay feedback and DCD information. All five options are shown in the following sections.

## PLC Input Assembly Instance 100 (0x64)—8 Registers (VO Status/Fault)

This Assembly Instance includes only basic information about the status of the first 64 Virtual Outputs.

Table 6: PLC Input Assembly Instance 100 (0x64)—Safety Controller Outputs T > O

WORD #	WORD NAME	DATA TYPE
0	VO1 – VO16 (see <a href="#">Flags</a> on p. 123)	16-bit integer
1	VO17 – VO32 (see <a href="#">Flags</a> on p. 123)	16-bit integer
2	VO33 – VO48 (see <a href="#">Flags</a> on p. 123)	16-bit integer
3	VO49 – VO64 (see <a href="#">Flags</a> on p. 123)	16-bit integer
4	Fault bits for VO1 – VO16 (see <a href="#">Flags</a> on p. 123)	16-bit integer
5	Fault bits for VO17 – VO32 (see <a href="#">Flags</a> on p. 123)	16-bit integer
6	Fault bits for VO33 – VO48 (see <a href="#">Flags</a> on p. 123)	16-bit integer
7	Fault bits for VO49 – VO64 (see <a href="#">Flags</a> on p. 123)	16-bit integer

## PLC Input Assembly Instance 101 (0x65)—104 Registers (Fault Index Words)

This Assembly Instance includes the status of the first 64 Virtual Outputs plus advanced information about potential error codes and the status of the 2 safety outputs.

Table 7: PLC Input Assembly Instance 101 (0x65)—Safety Controller Outputs T > 0

WORD #	WORD NAME	DATA TYPE
0	VO1 – VO16 (see <a href="#">Flags</a> on p. 123)	16-bit integer
1	VO17 – VO32 (see <a href="#">Flags</a> on p. 123)	16-bit integer
2	VO33 – VO48 (see <a href="#">Flags</a> on p. 123)	16-bit integer
3	VO49 – VO64 (see <a href="#">Flags</a> on p. 123)	16-bit integer
4	Fault bits for VO1 – VO16 (see <a href="#">Flags</a> on p. 123)	16-bit integer
5	Fault bits for VO17 – VO32 (see <a href="#">Flags</a> on p. 123)	16-bit integer
6	Fault bits for VO33 – VO48 (see <a href="#">Flags</a> on p. 123)	16-bit integer
7	Fault bits for VO49 – VO64 (see <a href="#">Flags</a> on p. 123)	16-bit integer
8–39	<i>reserved</i>	16-bit integer
40	VO1 Fault Index	16-bit integer
41	VO2 Fault Index	16-bit integer
42	VO3 Fault Index	16-bit integer
43	VO4 Fault Index	16-bit integer
44	VO5 Fault Index	16-bit integer
45	VO6 Fault Index	16-bit integer
46	VO7 Fault Index	16-bit integer
47	VO8 Fault Index	16-bit integer
48	VO9 Fault Index	16-bit integer
49	VO10 Fault Index	16-bit integer
50	VO11 Fault Index	16-bit integer
51	VO12 Fault Index	16-bit integer
52	VO13 Fault Index	16-bit integer
53	VO14 Fault Index	16-bit integer
54	VO15 Fault Index	16-bit integer
55	VO16 Fault Index	16-bit integer
56	VO17 Fault Index	16-bit integer
57	VO18 Fault Index	16-bit integer
58	VO19 Fault Index	16-bit integer
59	VO20 Fault Index	16-bit integer
60	VO21 Fault Index	16-bit integer
61	VO22 Fault Index	16-bit integer
62	VO23 Fault Index	16-bit integer
63	VO24 Fault Index	16-bit integer
64	VO25 Fault Index	16-bit integer
65	VO26 Fault Index	16-bit integer
66	VO27 Fault Index	16-bit integer

WORD #	WORD NAME	DATA TYPE
67	VO28 Fault Index	16-bit integer
68	VO29 Fault Index	16-bit integer
69	VO30 Fault Index	16-bit integer
70	VO31 Fault Index	16-bit integer
71	VO32 Fault Index	16-bit integer
72	VO33 Fault Index	16-bit integer
73	VO34 Fault Index	16-bit integer
74	VO35 Fault Index	16-bit integer
75	VO36 Fault Index	16-bit integer
76	VO37 Fault Index	16-bit integer
77	VO38 Fault Index	16-bit integer
78	VO39 Fault Index	16-bit integer
79	VO40 Fault Index	16-bit integer
80	VO41 Fault Index	16-bit integer
81	VO42 Fault Index	16-bit integer
82	VO43 Fault Index	16-bit integer
83	VO44 Fault Index	16-bit integer
84	VO45 Fault Index	16-bit integer
85	VO46 Fault Index	16-bit integer
86	VO47 Fault Index	16-bit integer
87	VO48 Fault Index	16-bit integer
88	VO49 Fault Index	16-bit integer
89	VO50 Fault Index	16-bit integer
90	VO51 Fault Index	16-bit integer
91	VO52 Fault Index	16-bit integer
92	VO53 Fault Index	16-bit integer
93	VO54 Fault Index	16-bit integer
94	VO55 Fault Index	16-bit integer
95	VO56 Fault Index	16-bit integer
96	VO57 Fault Index	16-bit integer
97	VO58 Fault Index	16-bit integer
98	VO59 Fault Index	16-bit integer
99	VO60 Fault Index	16-bit integer
100	VO61 Fault Index	16-bit integer
101	VO62 Fault Index	16-bit integer
102	VO63 Fault Index	16-bit integer
103	VO64 Fault Index	16-bit integer

**Virtual Output (VO) Fault Index Words**

The Virtual Output Fault Index number is a way to represent the Fault Code associated with a given Virtual Output as a single 16-bit integer. This value is equivalent to the Error Message Index value for a given Virtual Output. See [SCR P Fault Code Table](#) on p. 188. Note that not every Virtual Output has an associated Fault Index.

**PLC Input Assembly Instance 102 (0x66)—150 Registers (Error Log Only)**

This Assembly Instance is used exclusively to access the fault log information on the Safety Controller.

Note that this Assembly Instance contains no information about the status of the Virtual Outputs.

The Safety Controller can store 10 faults in the log. Fault #1 is the most recent fault while higher fault numbers represent successively older faults.

Table 8: PLC Input Assembly Instance 102 (0—66) – Safety Controller Outputs T > 0

WORD #	WORD NAME	DATA TYPE
0–1	Fault #1 Time Stamp	32-bit integer
2–9	Fault #1 Name of I/O or System	2-word length + 12-ASCII characters
10	Fault #1 Error Code	16-bit integer
11	Fault #1 Advanced Error Code	16-bit integer
12	Fault #1 Error Message Index	16-bit integer
13–14	<i>reserved</i>	16-bit integer
15–16	Fault #2 Time Stamp	32-bit integer
17–24	Fault #2 Name of I/O or System	2-word length + 12-ASCII characters
25	Fault #2 Error Code	16-bit integer
26	Fault #2 Advanced Error Code	16-bit integer
27	Fault #2 Error Message Index	16-bit integer
28–29	<i>reserved</i>	16-bit integer
30–31	Fault #3 Time Stamp	32-bit integer
32–39	Fault #3 Name of I/O or System	2-word length + 12-ASCII characters
40	Fault #3 Error Code	16-bit integer
41	Fault #3 Advanced Error Code	16-bit integer
42	Fault #3 Error Message Index	16-bit integer
43–44	<i>reserved</i>	16-bit integer
45–46	Fault #4 Time Stamp	32-bit integer
47–54	Fault #4 Name of I/O or System	2-word length + 12-ASCII characters
55	Fault #4 Error Code	16-bit integer
56	Fault #4 Advanced Error Code	16-bit integer
57	Fault #4 Error Message Index	16-bit integer
58–59	<i>reserved</i>	16-bit integer
60–61	Fault #5 Time Stamp	32-bit integer
62–69	Fault #5 Name of I/O or System	2-word length + 12-ASCII characters
70	Fault #5 Error Code	16-bit integer
71	Fault #5 Advanced Error Code	16-bit integer
72	Fault #5 Error Message Index	16-bit integer
73–74	<i>reserved</i>	16-bit integer
75–76	Fault #6 Time Stamp	32-bit integer

WORD #	WORD NAME	DATA TYPE
77–84	Fault #6 Name of I/O or System	2-word length + 12-ASCII characters
85	Fault #6 Error Code	16-bit integer
86	Fault #6 Advanced Error Code	16-bit integer
87	Fault #6 Error Message Index	16-bit integer
88–89	<i>reserved</i>	16-bit integer
90–91	Fault #7 Time Stamp	32-bit integer
92–99	Fault #7 Name of I/O or System	2-word length + 12-ASCII characters
100	Fault #7 Error Code	16-bit integer
101	Fault #7 Advanced Error Code	16-bit integer
102	Fault #7 Error Message Index	16-bit integer
103–104	<i>reserved</i>	16-bit integer
105–106	Fault #8 Time Stamp	32-bit integer
107–114	Fault #8 Name of I/O or System	2-word length + 12-ASCII characters
115	Fault #8 Error Code	16-bit integer
116	Fault #8 Advanced Error Code	16-bit integer
117	Fault #8 Error Message Index	16-bit integer
118–119	<i>reserved</i>	16-bit integer
120–121	Fault #9 Time Stamp	32-bit integer
122–129	Fault #9 Name of I/O or System	2-word length + 12-ASCII characters
130	Fault #9 Error Code	16-bit integer
131	Fault #9 Advanced Error Code	16-bit integer
132	Fault #9 Error Message Index	16-bit integer
133–134	<i>reserved</i>	16-bit integer
135–136	Fault #10 Time Stamp	32-bit integer
137–144	Fault #10 Name of I/O or System	2-word length + 12-ASCII characters
145	Fault #10 Error Code	16-bit integer
146	Fault #10 Advanced Error Code	16-bit integer
147	Fault #10 Error Message Index	16-bit integer
148–149	<i>reserved</i>	16-bit integer

#### Fault Time Stamp

The relative time, in seconds, when the fault occurred. As measured from time 0, which is the last time the Safety Controller was powered up.

#### Name of I/O or System

This is an ASCII-string describing the source of the fault.

#### Error Code, Advanced Error Code, Error Index Message

The Error Code and the Advanced Error Code, taken together, form the Safety Controller Fault Code. The format for the Fault Code is `Error Code 'dot' Advanced Error Code`. For example, a Safety Controller Fault Code of 2.1 is represented by an Error Code of 2 and an Advanced Error Code of 1. The Error Message Index value is the Error Code and the Advanced Error Code together, and includes a leading zero with the Advanced Error Code, if necessary. For example, a Safety Controller Fault Code of 2.1 is represented by an Error Message Index of 201. The Error Message Index value is a convenient way to get the complete Fault Code while only reading a single 16-bit register.

## PLC Input Assembly Instance 103 (0x67)—35 Registers (Reset/Cancel Delay)

This Assembly Instance is used to communicate the state of all 256 Virtual Outputs and Faults and to provide the feedback information required to execute virtual resets and cancel delays.

WORD #	WORD NAME	DATA TYPE
0	VO1 – VO16 (see <a href="#">Flags</a> on p. 123)	16-bit integer
1	VO17 – VO32 (see <a href="#">Flags</a> on p. 123)	16-bit integer
2	VO33 – VO48 (see <a href="#">Flags</a> on p. 123)	16-bit integer
3	VO49 – VO64 (see <a href="#">Flags</a> on p. 123)	16-bit integer
4	VO65 – VO80 (see <a href="#">Extended Flags</a> on p. 124)	16-bit integer
5	VO81 – VO96 (see <a href="#">Extended Flags</a> on p. 124)	16-bit integer
6	VO97 – VO112 (see <a href="#">Extended Flags</a> on p. 124)	16-bit integer
7	VO113 – VO128 (see <a href="#">Extended Flags</a> on p. 124)	16-bit integer
8	VO129 – VO144 (see <a href="#">Extended Flags</a> on p. 124)	16-bit integer
9	VO145 – VO160 (see <a href="#">Extended Flags</a> on p. 124)	16-bit integer
10	VO161 – VO176 (see <a href="#">Extended Flags</a> on p. 124)	16-bit integer
11	VO177 – VO192 (see <a href="#">Extended Flags</a> on p. 124)	16-bit integer
12	VO193 – VO208 (see <a href="#">Extended Flags</a> on p. 124)	16-bit integer
13	VO209 – VO224 (see <a href="#">Extended Flags</a> on p. 124)	16-bit integer
14	VO225 – VO240 (see <a href="#">Extended Flags</a> on p. 124)	16-bit integer
15	VO241 – VO256 (see <a href="#">Extended Flags</a> on p. 124)	16-bit integer
16	Fault bits for VO1 – VO16 (see <a href="#">Flags</a> on p. 123)	16-bit integer
17	Fault bits for VO17 – VO32 (see <a href="#">Flags</a> on p. 123)	16-bit integer
18	Fault bits for VO33 – VO48 (see <a href="#">Flags</a> on p. 123)	16-bit integer
19	Fault bits for VO49 – VO64 (see <a href="#">Flags</a> on p. 123)	16-bit integer
20	Fault bits for VO65 – VO80 (see <a href="#">Extended Flags</a> on p. 124)	16-bit integer
21	Fault bits for VO81 – VO96 (see <a href="#">Extended Flags</a> on p. 124)	16-bit integer
22	Fault bits for VO97 – VO112 (see <a href="#">Extended Flags</a> on p. 124)	16-bit integer
23	Fault bits for VO113 – VO128 (see <a href="#">Extended Flags</a> on p. 124)	16-bit integer
24	Fault bits for VO129 – VO144 (see <a href="#">Extended Flags</a> on p. 124)	16-bit integer
25	Fault bits for VO145 – VO160 (see <a href="#">Extended Flags</a> on p. 124)	16-bit integer
26	Fault bits for VO161 – VO176 (see <a href="#">Extended Flags</a> on p. 124)	16-bit integer
27	Fault bits for VO177 – VO192 (see <a href="#">Extended Flags</a> on p. 124)	16-bit integer
28	Fault bits for VO193 – VO208 (see <a href="#">Extended Flags</a> on p. 124)	16-bit integer
29	Fault bits for VO209 – VO224 (see <a href="#">Extended Flags</a> on p. 124)	16-bit integer
30	Fault bits for VO225 – VO240 (see <a href="#">Extended Flags</a> on p. 124)	16-bit integer
31	Fault bits for VO241 – VO256 (see <a href="#">Extended Flags</a> on p. 124)	16-bit integer
32	Virtual Reset/Cancel Delay (1-16) Feedback [RCD Feedback Register Bits] (see <a href="#">Virtual Manual Reset and Cancel Delay (RCD) Sequence</a> on p.38)	16-bit integer
33	<i>reserved</i>	16-bit integer
34	RCD Actuation Code Feedback [RCD Enable Feedback Register] (see <a href="#">Virtual Manual Reset and Cancel Delay (RCD) Sequence</a> on p. 38)	16-bit integer

**PLC Input Assembly Instance 104 (0x68)—112 Registers (Reset/Cancel Delay plus DCD)**

This Assembly Instance is used to communicate the state of all 256 Virtual Outputs and Faults and to provide the feedback information required to execute virtual resets and cancel delays plus communicating performance and status information about DCD devices.

WORD #	WORD NAME	DATA TYPE
0	VO1 – VO16 (see <a href="#">Flags</a> on p. 123)	16-bit integer
1	VO17 – VO32 (see <a href="#">Flags</a> on p. 123)	16-bit integer
2	VO33 – VO48 (see <a href="#">Flags</a> on p. 123)	16-bit integer
3	VO49 – VO64 (see <a href="#">Flags</a> on p. 123)	16-bit integer
4	VO65 – VO80 (see <a href="#">Extended Flags</a> on p. 124)	16-bit integer
5	VO81 – VO96 (see <a href="#">Extended Flags</a> on p. 124)	16-bit integer
6	VO97 – VO112 (see <a href="#">Extended Flags</a> on p. 124)	16-bit integer
7	VO113 – VO128 (see <a href="#">Extended Flags</a> on p. 124)	16-bit integer
8	VO129 – VO144 (see <a href="#">Extended Flags</a> on p. 124)	16-bit integer
9	VO145 – VO160 (see <a href="#">Extended Flags</a> on p. 124)	16-bit integer
10	VO161 – VO176 (see <a href="#">Extended Flags</a> on p. 124)	16-bit integer
11	VO177 – VO192 (see <a href="#">Extended Flags</a> on p. 124)	16-bit integer
12	VO193 – VO208 (see <a href="#">Extended Flags</a> on p. 124)	16-bit integer
13	VO209 – VO224 (see <a href="#">Extended Flags</a> on p. 124)	16-bit integer
14	VO225 – VO240 (see <a href="#">Extended Flags</a> on p. 124)	16-bit integer
15	VO241 – VO256 (see <a href="#">Extended Flags</a> on p. 124)	16-bit integer
16	Fault bits for VO1 – VO16 (see <a href="#">Flags</a> on p. 123)	16-bit integer
17	Fault bits for VO17 – VO32 (see <a href="#">Flags</a> on p. 123)	16-bit integer
18	Fault bits for VO33 – VO48 (see <a href="#">Flags</a> on p. 123)	16-bit integer
19	Fault bits for VO49 – VO64 (see <a href="#">Flags</a> on p. 123)	16-bit integer
20	Fault bits for VO65 – VO80 (see <a href="#">Extended Flags</a> on p. 124)	16-bit integer
21	Fault bits for VO81 – VO96 (see <a href="#">Extended Flags</a> on p. 124)	16-bit integer
22	Fault bits for VO97 – VO112 (see <a href="#">Extended Flags</a> on p. 124)	16-bit integer
23	Fault bits for VO113 – VO128 (see <a href="#">Extended Flags</a> on p. 124)	16-bit integer
24	Fault bits for VO129 – VO144 (see <a href="#">Extended Flags</a> on p. 124)	16-bit integer
25	Fault bits for VO145 – VO160 (see <a href="#">Extended Flags</a> on p. 124)	16-bit integer
26	Fault bits for VO161 – VO176 (see <a href="#">Extended Flags</a> on p. 124)	16-bit integer
27	Fault bits for VO177 – VO192 (see <a href="#">Extended Flags</a> on p. 124)	16-bit integer
28	Fault bits for VO193 – VO208 (see <a href="#">Extended Flags</a> on p. 124)	16-bit integer
29	Fault bits for VO209 – VO224 (see <a href="#">Extended Flags</a> on p. 124)	16-bit integer
30	Fault bits for VO225 – VO240 (see <a href="#">Extended Flags</a> on p. 124)	16-bit integer
31	Fault bits for VO241 – VO256 (see <a href="#">Extended Flags</a> on p. 124)	16-bit integer
32	Virtual Reset/Cancel Delay (1–16) Feedback [RCD Feedback Register Bits] (see <a href="#">Virtual Manual Reset and Cancel Delay (RCD) Sequence</a> on p. 38)	16-bit integer
33	<i>reserved</i>	16-bit integer

WORD #	WORD NAME	DATA TYPE
34	RCD Actuation Code Feedback [RCD Enable Feedback Register] (see <a href="#">Virtual Manual Reset and Cancel Delay (RCD) Sequence</a> on p. 38)	16-bit integer
35–36	DCD System Status – Chain 1 Device Count	32-bit integer
37–38	DCD System Status – Chain 2 Device Count	32-bit integer
39–40	DCD System Status – Chain 1 Device On/Off Status	32-bit integer
41–42	DCD System Status – Chain 2 Device On/Off Status	32-bit integer
43–44	DCD System Status – Chain 1 Fault Status	32-bit integer
45–46	DCD System Status – Chain 2 Fault Status	32-bit integer
47–48	DCD System Status – Chain 1 Marginal Status	32-bit integer
49–50	DCD System Status – Chain 2 Marginal Status	32-bit integer
51–52	DCD System Status – Chain 1 Alert Status	32-bit integer
53–54	DCD System Status – Chain 2 Alert Status	32-bit integer
55–56	DCD System Status – Chain 1 Reset Status	32-bit integer
57–58	DCD System Status – Chain 2 Reset Status	32-bit integer
59–60	DCD System Status – Chain 1 Actuator Recognized	32-bit integer
61–62	DCD System Status – Chain 2 Actuator Recognized	32-bit integer
63–64	DCD System Status – Chain 1 System Status	32-bit integer
65–66	DCD System Status – Chain 2 System Status	32-bit integer
67–99	<i>reserved</i>	16-bit integer
100	DCD Read Request Acknowledge	16-bit integer
101	DCD Chain Requested Acknowledge	16-bit integer
102	DCD Device Requested Acknowledge	16-bit integer
103–112	DCD Individual Device-Specific Data (see <a href="#">DCD Individual Device-Specific Data</a> on p. 121)	16-bit integer

### DCD Chain System Status

BERNSTEIN has created a couple of words that can be accessed quickly by the PLC to indicate if there are any problems with the DCD chain.

This information has the following format:

Information	Type	Data Size
DCD chain count does not match configuration	SCR P Alert	1 bit
DCD chain order does not match configuration	SCR P Alert	1 bit
No DCD data detected on configured DCD chain	SCR P Alert	1 bit
Invalid (non-DCD) device in DCD chain	SCR P Alert	1 bit
<i>Reserved</i>		1 bit
DCD chain terminator plug missing	DCD Status	1 bit
SI-RF high or unique sensor not taught an actuator	DCD Fault	1 bit
Wrong actuator presented to a high or unique sensor	DCD Fault	1 bit
Internal error on an DCD device in the chain	DCD Fault	1 bit
DCD Output fault detected, output turn off counter started	DCD Fault	1 bit



Information	Type	Data Size
<i>Reserved</i>		2 bits
DCD Chain OSSD Status	DCD Status	1 bit

### DCD Individual Device-Specific Data

#### SI-RF Device

In the case of the DCD-enabled gate switch (SI-RF), the DCD Individual Device-Specific Data coming back from the SI-RF device has the following format:

Information	Abbreviation	Data size
Safety Input Fault	EF	1 bit
<i>reserved</i>	--	1 bit
Sensor Not Paired	BE	1-bit
DCD Data Error	CE	1-bit
Wrong Actuator	FB	1-bit
Marginal Range	BB	1-bit
Actuator Detected	RB	1-bit
Output Error	QS	1-bit
Input 2	E2	1-bit
Input 1	E1	1-bit
Local Reset Expected	LS	1-bit
Operating Voltage Warning	UW	1-bit
Operating Voltage Error	UF	1-bit
Output 2	Q2	1-bit
Output 1	Q1	1-bit
Power Cycle Required	MF	1-bit
Fault Tolerant Outputs	MQ	1-bit
Local Reset Unit	MS	1-bit
Cascadable	RS	1-bit
High Level Coding	HC	1-bit
Teach-ins Remaining	RTP	4-bit
Device ID	--	5-bit
Range Warning Count	--	6-bit
Output Switch-off Time	--	5-bit
Number of Voltage Errors	--	8-bit
Internal Temperature <sup>20</sup>	--	8-bit
Actuator Distance <sup>20</sup>	--	8-bit
Supply Voltage <sup>20</sup>	--	8-bit
Expected Company Name	--	4-bit
Received Company Name	--	4-bit

<sup>20</sup> For conversion to Internal Temperature, Actuator Distance, and Supply Voltage, see [Temperature, Voltage, and Distance Conversion Information](#) on p. 162.

Information	Abbreviation	Data size
Expected Code	--	16-bit
Received Code	--	16-bit
Internal Error A	--	16-bit
Internal Error B	--	16-bit

### 9.4.2 Fault Examples

The following figure shows a fault from the BERNSTEIN Safety Controller Software fault log.

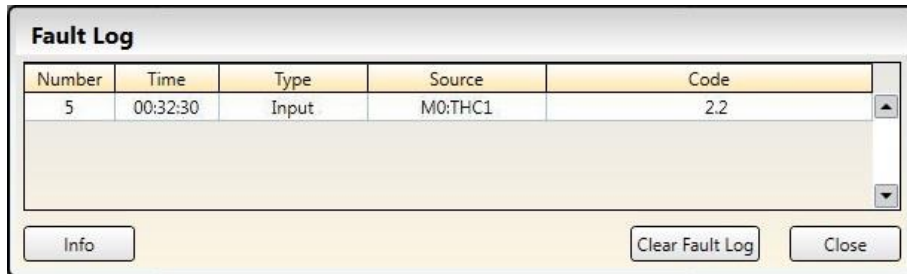

Figure 100: Fault Log with One Fault

The following figure shows the same fault as seen in the EtherNet/IP registers.

Register	Value	Format	Address
XS26:1	{...}	{...}	AB:ETHER
XS26:1.Data	{...}	Decimal	INT[150]
XS26:1.Data[0]	1950	Decimal	INT
XS26:1.Data[1]	0	Decimal	INT
XS26:1.Data[2]	4	Decimal	INT
XS26:1.Data[3]	0	Decimal	INT
XS26:1.Data[4]	'HT'	ASCII	INT
XS26:1.Data[5]	'1C'	ASCII	INT
XS26:1.Data[6]	0	Decimal	INT
XS26:1.Data[7]	0	Decimal	INT
XS26:1.Data[8]	0	Decimal	INT
XS26:1.Data[9]	0	Decimal	INT
XS26:1.Data[10]	2	Decimal	INT
XS26:1.Data[11]	2	Decimal	INT
XS26:1.Data[12]	202	Decimal	INT
XS26:1.Data[13]	34	Decimal	INT
XS26:1.Data[14]	1	Decimal	INT

Annotations in red text with brackets point to specific values:

- Time Stamp: 1950
- I/O or System Name Length (# of ASCII Characters): 4
- I/O or System Name Length (Space for 12 of ASCII Characters): 0
- Error Code: 2
- Advanced Error Code: 2
- Fault Error Message Index: 202
- Reserved: 34

Figure 101: EtherNet/IP Registers with One Fault

Note the ControlLogix string format, wherein the ASCII characters are shown, two per register, backwards. "THC1" becomes "HT" in register 4, followed by "1C" in register 5.

Fault Error Message Index 202 = Fault Code 2.2 (Simultaneity Fault). For more Fault information, see [SCR P-2 Fault Code Table](#) on p. 188.

The following figure shows two faults in the XS26-2E software fault log.

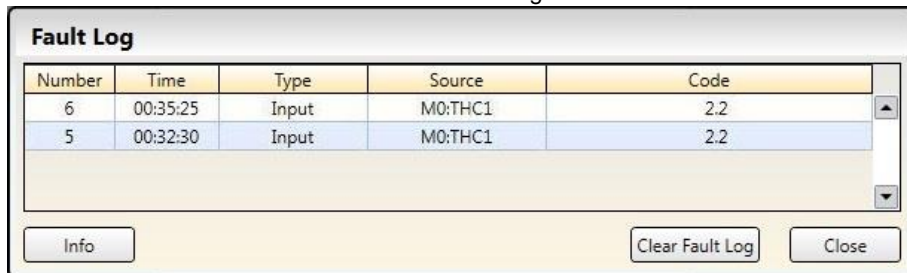

Figure 102: Fault Log with Two Faults

The following figure shows the same two faults in the PLC registers. Note how the newer Error #2 pushes Error #1 down the list.

[-] XS26.I		{...}	{...}		AB:ETHERNET_...
[-] XS26.I.Data		{...}	{...}	Decimal	INT[150]
[+] XS26.I.Data[0]	Time Stamp	2125		Decimal	INT
[+] XS26.I.Data[1]		0		Decimal	INT
[+] XS26.I.Data[2]	I/O or System Name Length (# of ASCII Characters)	4		Decimal	INT
[+] XS26.I.Data[3]		0		Decimal	INT
[+] XS26.I.Data[4]		'HT'		ASCII	INT
[+] XS26.I.Data[5]		'1C'		ASCII	INT
[+] XS26.I.Data[6]	I/O or System Name Length (Space for 12 of ASCII Characters)	0		Decimal	INT
[+] XS26.I.Data[7]		0		Decimal	INT
[+] XS26.I.Data[8]		0		Decimal	INT
[+] XS26.I.Data[9]		0		Decimal	INT
[+] XS26.I.Data[10]	Error Code	2		Decimal	INT
[+] XS26.I.Data[11]	Advanced Error Code	2		Decimal	INT
[+] XS26.I.Data[12]	Fault Error Message Index	202		Decimal	INT
[+] XS26.I.Data[13]	Reserved	34		Decimal	INT
[+] XS26.I.Data[14]		1		Decimal	INT
[+] XS26.I.Data[15]	Time Stamp	1950		Decimal	INT
[+] XS26.I.Data[16]		0		Decimal	INT
[+] XS26.I.Data[17]	I/O or System Name Length (# of ASCII Characters)	4		Decimal	INT
[+] XS26.I.Data[18]		0		Decimal	INT
[+] XS26.I.Data[19]		'HT'		ASCII	INT
[+] XS26.I.Data[20]		'1C'		ASCII	INT
[+] XS26.I.Data[21]	I/O or System Name Length (Space for 12 of ASCII Characters)	0		Decimal	INT
[+] XS26.I.Data[22]		0		Decimal	INT
[+] XS26.I.Data[23]		0		Decimal	INT
[+] XS26.I.Data[24]		0		Decimal	INT
[+] XS26.I.Data[25]	Error Code	2		Decimal	INT
[+] XS26.I.Data[26]	Advanced Error Code	2		Decimal	INT
[+] XS26.I.Data[27]	Fault Error Message Index	202		Decimal	INT
[+] XS26.I.Data[28]		34		Decimal	INT
[+] XS26.I.Data[29]	Reserved	1		Decimal	INT

Figure 103: EtherNet/IP Registers with Two Faults

### 9.4.3 Flags

Words 0 through 7, defined below, appear as the first 8 words in Assembly Instances 100, 101, and 103.

Table 9: Word #0, Virtual Output 1–16

Bit Position															
15	14	13	12	11	10	9	8	7	6	5	4	3	2	1	0
VO16	VO15	VO14	VO13	VO12	VO11	VO10	VO9	VO8	VO7	VO6	VO5	VO4	VO3	VO2	VO1

Table 10: Word #1, Virtual Output 17–32

Bit Position															
15	14	13	12	11	10	9	8	7	6	5	4	3	2	1	0
VO32	VO31	VO30	VO29	VO28	VO27	VO26	VO25	VO24	VO23	VO22	VO21	VO20	VO19	VO18	VO17

Table 11: Word #2, Virtual Output 33–48

Bit Position															
15	14	13	12	11	10	9	8	7	6	5	4	3	2	1	0
VO48	VO47	VO46	VO45	VO44	VO43	VO42	VO41	VO40	VO39	VO38	VO37	VO36	VO35	VO34	VO33

Table 12: Word #3, Virtual Output 49–64

Bit Position															
15	14	13	12	11	10	9	8	7	6	5	4	3	2	1	0
VO64	VO63	VO62	VO61	VO60	VO59	VO58	VO57	VO56	VO55	VO54	VO53	VO52	VO51	VO50	VO49

Table 13: Word #4, Fault Flag bits for Virtual Output 1–16

Note that not every Virtual Output has a defined Fault Flag.

Bit Position															
15	14	13	12	11	10	9	8	7	6	5	4	3	2	1	0
VO16	VO15	VO14	VO13	VO12	VO11	VO10	VO9	VO8	VO7	VO6	VO5	VO4	VO3	VO2	VO1

Table 14: Word #5, Fault Flag bits for Virtual Output 17–32 Fault Flag

Note that not every Virtual Output has a defined Fault Flag.

Bit Position															
15	14	13	12	11	10	9	8	7	6	5	4	3	2	1	0
VO32	VO31	VO30	VO29	VO28	VO27	VO26	VO25	VO24	VO23	VO22	VO21	VO20	VO19	VO18	VO17

Table 15: Word #6, Fault Flag bits for Virtual Output 33–48

Note that not every Virtual Output has a defined Fault Flag.

Bit Position															
15	14	13	12	11	10	9	8	7	6	5	4	3	2	1	0
VO48	VO47	VO46	VO45	VO44	VO43	VO42	VO41	VO40	VO39	VO38	VO37	VO36	VO35	VO34	VO33

Table 16: Word #7, Fault Flag bits for Virtual Output 49–64

Note that not every Virtual Output has a defined Fault Flag.

Bit Position															
15	14	13	12	11	10	9	8	7	6	5	4	3	2	1	0
VO64	VO63	VO62	VO61	VO60	VO59	VO58	VO57	VO56	VO55	VO54	VO53	VO52	VO51	VO50	VO49

## 9.4.4 Extended Flags

In addition to the first 64 virtual outputs listed above, Assembly Instance 103 adds 192 more (for a total of 256). The fault flag bits shift downward to make room for all 256 virtual outputs to be together.

Words 0 through 3 are the same as seen in [Flags](#) on p. 123. In the case of Assembly Instance 103 the following changes are made:

- Word #4 – Virtual Outputs 65 through 80, where VO65 is found in bit 0 and VO80 in bit 15
- Word #5 – Virtual Outputs 81 through 96, where VO81 is found in bit 0 and VO96 in bit 15
- Word #6 – Virtual Outputs 97 through 112, where VO97 is found in bit 0 and VO112 in bit 15
- Word #7 – Virtual Outputs 113 through 128, where VO113 is found in bit 0 and VO128 in bit 15
- Word #8 – Virtual Outputs 129 through 144, where VO129 is found in bit 0 and VO144 in bit 15
- Word #9 – Virtual Outputs 145 through 160, where VO145 is found in bit 0 and VO160 in bit 15
- Word #10 – Virtual Outputs 161 through 176, where VO161 is found in bit 0 and VO176 in bit 15
- Word #11 – Virtual Outputs 177 through 192, where VO177 is found in bit 0 and VO192 in bit 15
- Word #12 – Virtual Outputs 193 through 208, where VO193 is found in bit 0 and VO208 in bit 15
- Word #13 – Virtual Outputs 209 through 224, where VO209 is found in bit 0 and VO224 in bit 15
- Word #14 – Virtual Outputs 225 through 240, where VO225 is found in bit 0 and VO240 in bit 15
- Word #15 – Virtual Outputs 241 through 256, where VO241 is found in bit 0 and VO256 in bit 15
- Word #16 through #19 are the same as Word #4 through #7 as seen in [Flags](#) on p. 123. Assembly Instance 103 also includes more fault flag bits, as seen below
- Word #20 – Fault Bits for VO65 through VO80, where the fault for VO65 is found in bit 0 and VO80 in bit 15

This pattern continues for Word #21 through #31, covering the remainder of the fault bits for the 256 total Virtual Outputs.

## 9.5 Modbus/TCP

The Modbus/TCP protocol provides device information using register and coil banks defined by the slave device.

This section defines the register and coil banks. By specification, Modbus/TCP uses TCP port 502. The XS/SC26 does not support a Unit ID of 0 (sometimes called Slave ID or Device ID).

The following registers are used to send output values from the Safety Controller to the PLC. These can be read as Input Registers (30000) using Modbus function code 04 (Read Input Registers). The same values can also be read as Holding

Registers (40000) using Modbus function code 03 (Read Holding Registers). The status information for all the virtual outputs and their fault flags, contained in the first 8 registers, can also be read as Inputs (10000) using Modbus function code 02 (Read Input Status).



**Note:** FID 2 and later XS/SC26-2 Safety Controllers differ from FID 1 XS/SC26-2 models in that FID 2 and later no longer allows access to the first 64 Virtual Outputs using Modbus/TCP Coils 0001–00064, nor the first 64 Virtual Output Faults bits using Modbus/TCP Coils 00065–00128.

### The First 64 Virtual Outputs and Virtual Output Faults (Inputs 10001-10128)

Table 17: 02: Read Input Status

Input #	NAME	Input #	NAME
10001	VO1	10065	VO1 Fault bit
10002	VO2	10066	VO2 Fault bit
10003	VO3	10067	VO3 Fault bit
...	...	...	...
10063	VO63	10127	VO63 Fault bit
10064	VO64	10128	VO64 Fault bit

## All 256 Virtual Outputs and Virtual Output Faults (Inputs 11001-11256, 12001-12256)

Table 18: 02: Read Input Status

Input #	NAME	Input #	NAME
11001	VO1	12001	VO1 Fault bit
11002	VO2	12002	VO2 Fault bit
11003	VO3	12003	VO3 Fault bit
...	...	...	...
11255	VO255	12255	VO255 Fault bit
11256	VO256	12256	VO256 Fault bit

## Virtual Input, Virtual Reset/Cancel Delay Control and Feedback (Coils 3001-30064, 4001-4016, Inputs 15001-15016)

See [Virtual Manual Reset and Cancel Delay \(RCD\) Sequence](#) on p. 38.

Table 19: 05: Write Single Coil; 02: Read Input Status

Input #	NAME	Input #	NAME
3001	VI1 On/Off	15001	VRCD1 Feedback
3002	VI2 On/Off	15002	VRCD2 Feedback
...	...	...	...
3064	VI 64 On/Off	15016	VRCD16 Feedback
4001	VRCD1 On/Off		
4002	VRCD2 On/Off		
...			
4016	VRCD16 On/Off		

## Safety Controller Output Registers (Modbus/TCP Input or Holding Registers)

Input REG #	Holding REG #	WORD NAME	DATA TYPE
1	1	VO1 – VO16 (see <a href="#">Flags</a> on p. 134)	16-bit integer
2	2	VO17 – VO32 (see <a href="#">Flags</a> on p. 134)	16-bit integer
3	3	VO33 – VO48 (see <a href="#">Flags</a> on p. 134)	16-bit integer
4	4	VO49 – VO64 (see <a href="#">Flags</a> on p. 134)	16-bit integer
5	5	Fault bits for VO1 – VO16 (see <a href="#">Flags</a> on p. 134)	16-bit integer
6	6	Fault bits for VO17 – VO32 (see <a href="#">Flags</a> on p. 134)	16-bit integer
7	7	Fault bits for VO33 – VO48 (see <a href="#">Flags</a> on p. 134)	16-bit integer
8	8	Fault bits for VO49 – VO64 (see <a href="#">Flags</a> on p. 134)	16-bit integer
	9	Virtual Input On/Off (1-16)	16-bit integer
	10	Virtual Input On/Off (17-32)	16-bit integer
	11	Virtual Input On/Off (33-48)	16-bit integer

Input REG #	Holding REG #	WORD NAME	DATA TYPE
	12	Virtual Input On/Off (49-64)	16-bit integer
13–16	13–16	<i>reserved</i>	16-bit integer
	17	Virtual Reset/Cancel Delay (1–16) [RCD Register Bits] (see <a href="#">Virtual Manual Reset and Cancel Delay (RCD) Sequence</a> on p. 38)	16-bit integer
18	18	<i>reserved</i>	16-bit integer
	19	RCD Actuation Code [RCD Enable Register] (see <a href="#">Virtual Manual Reset and Cancel Delay (RCD) Sequence</a> on p. 38)	16-bit integer
20	20	Virtual Reset/Cancel Delay (1–16) Feedback [RCD Feedback Register Bits] (see <a href="#">Virtual Manual Reset and Cancel Delay (RCD) Sequence</a> on p. 38)	16-bit integer
21	21	<i>reserved</i>	16-bit integer
22	22	RCD Actuation Code Feedback [RCD Enable Feedback Register] (see <a href="#">Virtual Manual Reset and Cancel Delay (RCD) Sequence</a> on p. 38)	16-bit integer
23–40	23–40	<i>reserved</i>	16-bit integer
41	41	VO1 Fault Index	16-bit integer
42	42	VO2 Fault Index	16-bit integer
43	43	VO3 Fault Index	16-bit integer
44	44	VO4 Fault Index	16-bit integer
45	45	VO5 Fault Index	16-bit integer
46	46	VO6 Fault Index	16-bit integer
47	47	VO7 Fault Index	16-bit integer
48	48	VO8 Fault Index	16-bit integer
49	49	VO9 Fault Index	16-bit integer
50	50	VO10 Fault Index	16-bit integer
51	51	VO11 Fault Index	16-bit integer
52	52	VO12 Fault Index	16-bit integer
53	53	VO13 Fault Index	16-bit integer
54	54	VO14 Fault Index	16-bit integer
55	55	VO15 Fault Index	16-bit integer
56	56	VO16 Fault Index	16-bit integer
57	57	VO17 Fault Index	16-bit integer
58	58	VO18 Fault Index	16-bit integer
59	59	VO19 Fault Index	16-bit integer
60	60	VO20 Fault Index	16-bit integer
61	61	VO21 Fault Index	16-bit integer
62	62	VO22 Fault Index	16-bit integer
63	63	VO23 Fault Index	16-bit integer
64	64	VO24 Fault Index	16-bit integer
65	65	VO25 Fault Index	16-bit integer

Input REG #	Holding REG #	WORD NAME	DATA TYPE
66	66	VO26 Fault Index	16-bit integer
67	67	VO27 Fault Index	16-bit integer
68	68	VO28 Fault Index	16-bit integer
69	69	VO29 Fault Index	16-bit integer
70	70	VO30 Fault Index	16-bit integer
71	71	VO31 Fault Index	16-bit integer
72	72	VO32 Fault Index	16-bit integer
73	73	VO33 Fault Index	16-bit integer
74	74	VO34 Fault Index	16-bit integer
75	75	VO35 Fault Index	16-bit integer
76	76	VO36 Fault Index	16-bit integer
77	77	VO37 Fault Index	16-bit integer
78	78	VO38 Fault Index	16-bit integer
79	79	VO39 Fault Index	16-bit integer
80	80	VO40 Fault Index	16-bit integer
81	81	VO41 Fault Index	16-bit integer
82	82	VO42 Fault Index	16-bit integer
83	83	VO43 Fault Index	16-bit integer
84	84	VO44 Fault Index	16-bit integer
85	85	VO45 Fault Index	16-bit integer
86	86	VO46 Fault Index	16-bit integer
87	87	VO47 Fault Index	16-bit integer
88	88	VO48 Fault Index	16-bit integer
89	89	VO49 Fault Index	16-bit integer
90	90	VO50 Fault Index	16-bit integer
91	91	VO51 Fault Index	16-bit integer
92	92	VO52 Fault Index	16-bit integer
93	93	VO53 Fault Index	16-bit integer
94	94	VO54 Fault Index	16-bit integer
95	95	VO55 Fault Index	16-bit integer
96	96	VO56 Fault Index	16-bit integer
97	97	VO57 Fault Index	16-bit integer
98	98	VO58 Fault Index	16-bit integer
99	99	VO59 Fault Index	16-bit integer
100	100	VO60 Fault Index	16-bit integer
101	101	VO61 Fault Index	16-bit integer
102	102	VO62 Fault Index	16-bit integer
103	103	VO63 Fault Index	16-bit integer
104	104	VO64 Fault Index	16-bit integer



Input REG #	Holding REG #	WORD NAME	DATA TYPE
105–106	105–106	VO1 Complete Fault Code	32-bit integer
107–108	107–108	VO2 Complete Fault Code	32-bit integer
109–110	109–110	VO3 Complete Fault Code	32-bit integer
111–112	111–112	VO4 Complete Fault Code	32-bit integer
113–114	113–114	VO5 Complete Fault Code	32-bit integer
115–116	115–116	VO6 Complete Fault Code	32-bit integer
117–118	117–118	VO7 Complete Fault Code	32-bit integer
119–120	119–120	VO8 Complete Fault Code	32-bit integer
121–122	121–122	VO9 Complete Fault Code	32-bit integer
123–124	123–124	VO10 Complete Fault Code	32-bit integer
125–126	125–126	VO11 Complete Fault Code	32-bit integer
127–128	127–128	VO12 Complete Fault Code	32-bit integer
129–130	129–130	VO13 Complete Fault Code	32-bit integer
131–132	131–132	VO14 Complete Fault Code	32-bit integer
133–134	133–134	VO15 Complete Fault Code	32-bit integer
135–136	135–136	VO16 Complete Fault Code	32-bit integer
137–138	137–138	VO17 Complete Fault Code	32-bit integer
139–140	139–140	VO18 Complete Fault Code	32-bit integer
141–142	141–142	VO19 Complete Fault Code	32-bit integer
143–144	143–144	VO20 Complete Fault Code	32-bit integer
145–146	145–146	VO21 Complete Fault Code	32-bit integer
147–148	147–148	VO22 Complete Fault Code	32-bit integer
149–150	149–150	VO23 Complete Fault Code	32-bit integer
151–152	151–152	VO24 Complete Fault Code	32-bit integer
153–154	153–154	VO25 Complete Fault Code	32-bit integer
155–156	155–156	VO26 Complete Fault Code	32-bit integer
157–158	157–158	VO27 Complete Fault Code	32-bit integer
159–160	159–160	VO28 Complete Fault Code	32-bit integer
161–162	161–162	VO29 Complete Fault Code	32-bit integer
163–164	163–164	VO30 Complete Fault Code	32-bit integer
165–166	165–166	VO31 Complete Fault Code	32-bit integer
167–168	167–168	VO32 Complete Fault Code	32-bit integer
169–170	169–170	VO33 Complete Fault Code	32-bit integer
171–172	171–172	VO34 Complete Fault Code	32-bit integer
173–174	173–174	VO35 Complete Fault Code	32-bit integer
175–176	175–176	VO36 Complete Fault Code	32-bit integer
177–178	177–178	VO37 Complete Fault Code	32-bit integer
179–180	179–180	VO38 Complete Fault Code	32-bit integer
181–182	181–182	VO39 Complete Fault Code	32-bit integer

Input REG #	Holding REG #	WORD NAME	DATA TYPE
183–184	183–184	VO40 Complete Fault Code	32-bit integer
185–186	185–186	VO41 Complete Fault Code	32-bit integer
187–188	187–188	VO42 Complete Fault Code	32-bit integer
189–190	189–190	VO43 Complete Fault Code	32-bit integer
191–192	191–192	VO44 Complete Fault Code	32-bit integer
193–194	193–194	VO45 Complete Fault Code	32-bit integer
195–196	195–196	VO46 Complete Fault Code	32-bit integer
197–198	197–198	VO47 Complete Fault Code	32-bit integer
199–200	199–200	VO48 Complete Fault Code	32-bit integer
201–202	201–202	VO49 Complete Fault Code	32-bit integer
203–204	203–204	VO50 Complete Fault Code	32-bit integer
205–206	205–206	VO51 Complete Fault Code	32-bit integer
207–208	207–208	VO52 Complete Fault Code	32-bit integer
209–210	209–210	VO53 Complete Fault Code	32-bit integer
211–212	211–212	VO54 Complete Fault Code	32-bit integer
213–214	213–214	VO55 Complete Fault Code	32-bit integer
215–216	215–216	VO56 Complete Fault Code	32-bit integer
217–218	217–218	VO57 Complete Fault Code	32-bit integer
219–220	219–220	VO58 Complete Fault Code	32-bit integer
221–222	221–222	VO59 Complete Fault Code	32-bit integer
223–224	223–224	VO60 Complete Fault Code	32-bit integer
225–226	225–226	VO61 Complete Fault Code	32-bit integer
227–228	227–228	VO62 Complete Fault Code	32-bit integer
229–230	229–230	VO63 Complete Fault Code	32-bit integer
231–232	231–232	VO64 Complete Fault Code	32-bit integer
233–234	233–234	Fault #1 Time Stamp	32-bit integer
235–242	235–242	Fault #1 Name of I/O or System	2-word length + 12-ASCII characters
243	243	Fault #1 Error Code	16-bit integer
244	244	Fault #1 Advanced Error Code	16-bit integer
245	245	Fault #1 Error Message Index	16-bit integer
246–247	246–247	<i>reserved</i>	16-bit integer
248–249	248–249	Fault #2 Time Stamp	32-bit integer
250–257	250–257	Fault #2 Name of I/O or System	2-word length + 12-ASCII characters
258	258	Fault #2 Error Code	16-bit integer
259	259	Fault #2 Advanced Error Code	16-bit integer
260	260	Fault #2 Error Message Index	16-bit integer
261–262	261–262	<i>reserved</i>	16-bit integer
263–264	263–264	Fault #3 Time Stamp	32-bit integer
265–272	265–272	Fault #3 Name of I/O or System	2-word length + 12-ASCII characters

Input REG #	Holding REG #	WORD NAME	DATA TYPE
273	273	Fault #3 Error Code	16-bit integer
274	274	Fault #3 Advanced Error Code	16-bit integer
275	275	Fault #3 Error Message Index	16-bit integer
276–277	276–277	<i>reserved</i>	16-bit integer
278–279	278–279	Fault #4 Time Stamp	32-bit integer
280–287	280–287	Fault #4 Name of I/O or System	2-word length + 12-ASCII characters
288	288	Fault #4 Error Code	16-bit integer
289	289	Fault #4 Advanced Error Code	16-bit integer
290	290	Fault #4 Error Message Index	16-bit integer
291–292	291–292	<i>reserved</i>	16-bit integer
293–294	293–294	Fault #5 Time Stamp	32-bit integer
295–302	295–302	Fault #5 Name of I/O or System	2-word length + 12-ASCII characters
303	303	Fault #5 Error Code	16-bit integer
304	304	Fault #5 Advanced Error Code	16-bit integer
305	305	Fault #5 Error Message Index	16-bit integer
306–307	306–307	<i>reserved</i>	16-bit integer
308–309	308–309	Fault #6 Time Stamp	32-bit integer
310–317	310–317	Fault #6 Name of I/O or System	2-word length + 12-ASCII characters
318	318	Fault #6 Error Code	16-bit integer
319	319	Fault #6 Advanced Error Code	16-bit integer
320	320	Fault #6 Error Message Index	16-bit integer
321–322	321–322	<i>reserved</i>	16-bit integer
323–324	323–324	Fault #7 Time Stamp	32-bit integer
325–332	325–332	Fault #7 Name of I/O or System	2-word length + 12-ASCII characters
333	333	Fault #7 Error Code	16-bit integer
334	334	Fault #7 Advanced Error Code	16-bit integer
335	335	Fault #7 Error Message Index	16-bit integer
336–337	336–337	<i>reserved</i>	16-bit integer
338–339	338–339	Fault #8 Time Stamp	32-bit integer
340–347	340–347	Fault #8 Name of I/O or System	2-word length + 12-ASCII characters
348	348	Fault #8 Error Code	16-bit integer
349	349	Fault #8 Advanced Error Code	16-bit integer
350	350	Fault #8 Error Message Index	16-bit integer
351–352	351–352	<i>reserved</i>	16-bit integer
353–354	353–354	Fault #9 Time Stamp	32-bit integer
355–362	355–362	Fault #9 Name of I/O or System	2-word length + 12-ASCII characters
363	363	Fault #9 Error Code	16-bit integer
364	364	Fault #9 Advanced Error Code	16-bit integer
365	365	Fault #9 Error Message Index	16-bit integer

Input REG #	Holding REG #	WORD NAME	DATA TYPE
366–367	366–367	<i>reserved</i>	16-bit integer
368–369	368–369	Fault #10 Time Stamp	32-bit integer
370–377	370–377	Fault #10 Name of I/O or System	2-word length + 12-ASCII characters
378	378	Fault #10 Error Code	16-bit integer
379	379	Fault #10 Advanced Error Code	16-bit integer
380	380	Fault #10 Error Message Index	16-bit integer
381–382	381–382	<i>reserved</i>	16-bit integer
383–384	383–384	Seconds Since Boot	32-bit integer
385	385	Operating Mode	16-bit integer
386–395	386–395	ConfigName	2-word length + 16-ASCII characters
396–397	396–397	Config CRC	32-bit integer
398–900	398–900	<i>reserved</i>	16-bit integer
901	901	VO1 – VO16 (see <a href="#">Flags</a> on p. 134)	16-bit integer
902	902	VO17 – VO32 (see <a href="#">Flags</a> on p. 134)	16-bit integer
903	903	VO33 – VO48 (see <a href="#">Flags</a> on p. 134)	16-bit integer
904	904	VO49 – VO64 (see <a href="#">Flags</a> on p. 134)	16-bit integer
905	905	VO65 – VO80 (see <a href="#">Extended Flags</a> on p. 135)	16-bit integer
906	906	VO81 – VO96 (see <a href="#">Extended Flags</a> on p. 135)	16-bit integer
907	907	VO97 – VO112 (see <a href="#">Extended Flags</a> on p. 135)	16-bit integer
908	908	VO113 – VO128 (see <a href="#">Extended Flags</a> on p. 135)	16-bit integer
909	909	VO129 – VO144 (see <a href="#">Extended Flags</a> on p. 135)	16-bit integer
910	910	VO145 – VO160 (see <a href="#">Extended Flags</a> on p. 135)	16-bit integer
911	911	VO161 – VO176 (see <a href="#">Extended Flags</a> on p. 135)	16-bit integer
912	912	VO177 – VO192 (see <a href="#">Extended Flags</a> on p. 135)	16-bit integer
913	913	VO193 – VO208 (see <a href="#">Extended Flags</a> on p. 135)	16-bit integer
914	914	VO209 – VO224 (see <a href="#">Extended Flags</a> on p. 135)	16-bit integer
915	915	VO225 – VO240 (see <a href="#">Extended Flags</a> on p. 135)	16-bit integer
916	916	VO241 – VO256 (see <a href="#">Extended Flags</a> on p. 135)	16-bit integer
917	917	Fault bits for VO1 – VO16 (see <a href="#">Flags</a> on p. 134)	16-bit integer
918	918	Fault bits for VO17 – VO32 (see <a href="#">Flags</a> on p. 134)	16-bit integer
919	919	Fault bits for VO33 – VO48 (see <a href="#">Flags</a> on p. 134)	16-bit integer
920	920	Fault bits for VO49 – VO64 (see <a href="#">Flags</a> on p. 134)	16-bit integer
921	921	Fault bits for VO65 – VO80 (see <a href="#">Extended Flags</a> on p. 135)	16-bit integer
922	922	Fault bits for VO81 – VO96 (see <a href="#">Extended Flags</a> on p. 135)	16-bit integer
923	923	Fault bits for VO97 – VO112 (see <a href="#">Extended Flags</a> on p. 135)	16-bit integer
924	924	Fault bits for VO113 – VO128 (see <a href="#">Extended Flags</a> on p. 135)	16-bit integer

Input REG #	Holding REG #	WORD NAME	DATA TYPE
925	925	Fault bits for VO129 – VO144 (see <a href="#">Extended Flags</a> on p. 135)	16-bit integer
926	926	Fault bits for VO145 – VO160 (see <a href="#">Extended Flags</a> on p. 135)	16-bit integer
926	926	Fault bits for VO161 – VO176 (see <a href="#">Extended Flags</a> on p. 135)	16-bit integer
928	928	Fault bits for VO177 – VO192 (see <a href="#">Extended Flags</a> on p. 135)	16-bit integer
929	929	Fault bits for VO193 – VO208 (see <a href="#">Extended Flags</a> on p. 135)	16-bit integer
930	930	Fault bits for VO209 – VO224 (see <a href="#">Extended Flags</a> on p. 135)	16-bit integer
931	931	Fault bits for VO225 – VO240 (see <a href="#">Extended Flags</a> on p. 135)	16-bit integer
932	932	Fault bits for VO241 – VO256 (see <a href="#">Extended Flags</a> on p. 135)	16-bit integer
933–934	933–934	RCD bits feedback (see <a href="#">Virtual Manual Reset and Cancel Delay (RCD) Sequence</a> on p. 38)	32-bit integer
935	935	RCD Enable feedback (see <a href="#">Virtual Manual Reset and Cancel Delay (RCD) Sequence</a> on p. 38)	16-bit integer
936	936	VO1 Fault Index	16-bit integer
937	937	VO2 Fault Index	16-bit integer
938	938	VO3 Fault Index	16-bit integer
...	...	...	...
1190	1190	VO256 Fault Index	16-bit integer
1191–1192	1191–1192	VO1 Complete Fault Code	32-bit integer
1193–1194	1193–1194	VO2 Complete Fault Code	32-bit integer
1195–1196	1195–1196	VO3 Complete Fault Code	32-bit integer
1197–1198	1197–1198	VO4 Complete Fault Code	32-bit integer
...	...	...	...
1702–1703	1702–1703	VO256 Complete Fault Code	32-bit integer
1704–1705	1704–1705	DCD System Status- Chain 1 Device Count	32-bit integer
1706–1707	1706–1707	DCD System Status- Chain 2 Device Count	32-bit integer
1708–1709	1708–1709	DCD System Status- Chain 1 Device On/Off Status	32-bit integer
1710–1711	1710–1711	DCD System Status- Chain 2 Device On/Off Status	32-bit integer
1712–1713	1712–1713	DCD System Status- Chain 1 Fault Status	32-bit integer
1714–1715	1714–1715	DCD System Status- Chain 2 Fault Status	32-bit integer
1716–1717	1716–1717	DCD System Status- Chain 1 Marginal Status	32-bit integer
1718–1719	1718–1719	DCD System Status- Chain 2 Marginal Status	32-bit integer
1720–1721	1720–1721	DCD System Status- Chain 1 Alert Status	32-bit integer
1722–1723	1722–1723	DCD System Status- Chain 2 Alert Status	32-bit integer
1724–1725	1724–1725	DCD System Status- Chain 1 Reset Status	32-bit integer
1726–1727	1726–1727	DCD System Status- Chain 2 Reset Status	32-bit integer

Input REG #	Holding REG #	WORD NAME	DATA TYPE
1728–1729	1728–1729	DCD System Status- Chain 1 Actuator Recognized	32-bit integer
1730–1731	1730–1731	DCD System Status- Chain 2 Actuator Recognized	32-bit integer
1732–1733	1732–1733	DCD System Status- Chain 1 System Status	32-bit integer
1734–1735	1734–1735	DCD System Status- Chain 2 System Status	32-bit integer
1736–1768	1736–1768	<i>reserved</i>	16-bit integer
1769	1769	DCD Read Request Acknowledge	16-bit integer
1770	1770	DCD Chain Requested Acknowledge	16-bit integer
1771	1771	DCD Device Requested Acknowledge	16-bit integer
1772–1780	1772–1780	DCD Individual Device-Specific Data <sup>26</sup>	16-bit integer
	1781	DCD Read Request	16-bit integer
	1782	DCD Chain Requested	16-bit integer
	1783	DCD Device Requested	16-bit integer

### 9.5.1 Flags

Registers 1 through 8, defined below, appear as the first 8 words in register map.

This represents the first 64 virtual outputs and the associated fault flags. The information in these registers can be read as Input Registers (30000) using Modbus function code 04 (Read Input Registers). The same values can also be read as Holding Registers (40000) using Modbus function code 03 (Read Holding Registers).

Table 20: Virtual Output 1–16

PLC Input register 30001 or Holding Register 40001, also Inputs 10001-16 or Coils 00001-16

bit 15	bit 14	bit 13	bit 12	bit 11	bit 10	bit 9	bit 8	bit 7	bit 6	bit 5	bit 4	bit 3	bit 2	bit 1	bit 0
VO16	VO15	VO14	VO13	VO12	VO11	VO10	VO9	VO8	VO7	VO6	VO5	VO4	VO3	VO2	VO1

Table 21: Virtual Output 17–32

PLC Input register 30002 or Holding Register 40002, also Inputs 10017-32 or Coils 00017-32

bit 15	bit 14	bit 13	bit 12	bit 11	bit 10	bit 9	bit 8	bit 7	bit 6	bit 5	bit 4	bit 3	bit 2	bit 1	bit 0
VO32	VO31	VO30	VO29	VO28	VO27	VO26	VO25	VO24	VO23	VO22	VO21	VO20	VO19	VO18	VO17

Table 22: Virtual Output 33–48

PLC Input register 30003 or Holding Register 40003, also Inputs 10033-48 or Coils 00033-48

bit 15	bit 14	bit 13	bit 12	bit 11	bit 10	bit 9	bit 8	bit 7	bit 6	bit 5	bit 4	bit 3	bit 2	bit 1	bit 0
VO48	VO47	VO46	VO45	VO44	VO43	VO42	VO41	VO40	VO39	VO38	VO37	VO36	VO35	VO34	VO33

Table 23: Virtual Output 49–64

PLC Input register 30004 or Holding Register 40004, also Inputs 10049-64 or Coils 00049-64

bit 15	bit 14	bit 13	bit 12	bit 11	bit 10	bit 9	bit 8	bit 7	bit 6	bit 5	bit 4	bit 3	bit 2	bit 1	bit 0
VO64	VO63	VO62	VO61	VO60	VO59	VO58	VO57	VO56	VO55	VO54	VO53	VO52	VO51	VO50	VO49

Table 24: Virtual Output Fault 1-16

PLC Input register 30005 or Holding Register 40005, also Inputs 10033-48 or Coils 00033-48

<sup>26</sup> For conversion to Internal Temperature, Actuator Distance, and Supply Voltage, see [Temperature, Voltage, and Distance Conversion Information](#) on p. 212.

bit 15	bit 14	bit 13	bit 12	bit 11	bit 10	bit 9	bit 8	bit 7	bit 6	bit 5	bit 4	bit 3	bit 2	bit 1	bit 0
VO16 fault	VO15 fault	VO14 fault	VO13 fault	VO12 fault	VO11 fault	VO10 fault	VO9 fault	VO8 fault	VO7 fault	VO6 fault	VO5 fault	VO4 fault	VO3 fault	VO2 fault	VO1 fault

Table 25: Virtual Output Fault 17-32

PLC Input register 30006 or Holding Register 40006, also Inputs 10049-64 or Coils 00049-64

bit 15	bit 14	bit 13	bit 12	bit 11	bit 10	bit 9	bit 8	bit 7	bit 6	bit 5	bit 4	bit 3	bit 2	bit 1	bit 0
VO32 fault	VO31 fault	VO30 fault	VO29 fault	VO28 fault	VO27 fault	VO26 fault	VO25 fault	VO24 fault	VO23 fault	VO22 fault	VO21 fault	VO20 fault	VO19 fault	VO18 fault	VO17 fault

Table 26: Virtual Output Fault 33-48

PLC Input register 30007 or Holding Register 40007, also Inputs 10033-48 or Coils 00033-48

bit 15	bit 14	bit 13	bit 12	bit 11	bit 10	bit 9	bit 8	bit 7	bit 6	bit 5	bit 4	bit 3	bit 2	bit 1	bit 0
VO48 fault	VO47 fault	VO46 fault	VO45 fault	VO44 fault	VO43 fault	VO42 fault	VO41 fault	VO40 fault	VO39 fault	VO38 fault	VO37 fault	VO36 fault	VO35 fault	VO34 fault	VO33 fault

Table 27: Virtual Output Fault 49-64

PLC Input register 30008 or Holding Register 40008, also Inputs 10049-64 or Coils 00049-64

bit 15	bit 14	bit 13	bit 12	bit 11	bit 10	bit 9	bit 8	bit 7	bit 6	bit 5	bit 4	bit 3	bit 2	bit 1	bit 0
VO64 fault	VO63 fault	VO62 fault	VO61 fault	VO60 fault	VO59 fault	VO58 fault	VO57 fault	VO56 fault	VO55 fault	VO54 fault	VO53 fault	VO52 fault	VO51 fault	VO50 fault	VO49 fault

## 9.5.2 Extended Flags

All 256 Virtual Outputs can be accessed in a way similar to that seen in [Flags](#) on p. 134.

Inputs 11001 through 11256 represent all 256 possible Virtual Outputs. These Virtual Outputs can also be read as Input Registers 901-916 or Holding Registers 901-916.

Inputs 12001 through 12256 are all 256 Virtual Output Faults. These Virtual Output Faults can also be read as Input Registers 917-932 or Holding Registers 917-932.

## 9.5.3 Outputs from Safety Controller (Inputs to PLC)

The Output registers are used to push output values from the Safety Controller to the PLC. MSG (message) commands are used to Read (N7) from the Safety Controller.

Table 28: N7 REGS

REG #	WORD NAME	DATA TYPE
0	VO1 – VO16 (see <a href="#">Flags</a> on p. 143)	16-bit integer

REG #	WORD NAME	DATA TYPE
1	VO17 – VO32 (see <a href="#">Flags</a> on p. 143)	16-bit integer
2	VO33 – VO48 (see <a href="#">Flags</a> on p. 143)	16-bit integer
3	VO49 – VO64 (see <a href="#">Flags</a> on p. 143)	16-bit integer
4	Fault bits for VO1 – VO16 (see <a href="#">Flags</a> on p. 143)	16-bit integer
5	Fault bits for VO17 – VO32 (see <a href="#">Flags</a> on p. 143)	16-bit integer
6	Fault bits for VO33 – VO48 (see <a href="#">Flags</a> on p. 143)	16-bit integer
7	Fault bits for VO49 – VO64 (see <a href="#">Flags</a> on p. 143)	16-bit integer
8–18	<i>reserved</i>	16-bit integer
19	Virtual Reset/Cancel Delay (1–16) Feedback [RCD Feedback Register Bits] (see <a href="#">Virtual Manual Reset and Cancel Delay (RCD) Sequence</a> on p. 38)	16-bit integer
20	<i>reserved</i>	16-bit integer
21	RCD Actuation Code Feedback [RCD Enable Feedback Register] (see <a href="#">Virtual Manual Reset and Cancel Delay (RCD) Sequence</a> on p. 38)	16-bit integer
22–39	<i>reserved</i>	16-bit integer
40	VO1 Fault Index	16-bit integer
41	VO2 Fault Index	16-bit integer
42	VO3 Fault Index	16-bit integer
43	VO4 Fault Index	16-bit integer
44	VO5 Fault Index	16-bit integer
45	VO6 Fault Index	16-bit integer
46	VO7 Fault Index	16-bit integer
47	VO8 Fault Index	16-bit integer
48	VO9 Fault Index	16-bit integer
49	VO10 Fault Index	16-bit integer
50	VO11 Fault Index	16-bit integer
51	VO12 Fault Index	16-bit integer
52	VO13 Fault Index	16-bit integer
53	VO14 Fault Index	16-bit integer
54	VO15 Fault Index	16-bit integer
55	VO16 Fault Index	16-bit integer
56	VO17 Fault Index	16-bit integer
57	VO18 Fault Index	16-bit integer
58	VO19 Fault Index	16-bit integer
59	VO20 Fault Index	16-bit integer
60	VO21 Fault Index	16-bit integer
61	VO22 Fault Index	16-bit integer
62	VO23 Fault Index	16-bit integer
63	VO24 Fault Index	16-bit integer
64	VO25 Fault Index	16-bit integer



REG #	WORD NAME	DATA TYPE
65	VO26 Fault Index	16-bit integer
66	VO27 Fault Index	16-bit integer
67	VO28 Fault Index	16-bit integer
68	VO29 Fault Index	16-bit integer
69	VO30 Fault Index	16-bit integer
70	VO31 Fault Index	16-bit integer
71	VO32 Fault Index	16-bit integer
72	VO33 Fault Index	16-bit integer
73	VO34 Fault Index	16-bit integer
74	VO35 Fault Index	16-bit integer
75	VO36 Fault Index	16-bit integer
76	VO37 Fault Index	16-bit integer
77	VO38 Fault Index	16-bit integer
78	VO39 Fault Index	16-bit integer
79	VO40 Fault Index	16-bit integer
80	VO41 Fault Index	16-bit integer
81	VO42 Fault Index	16-bit integer
82	VO43 Fault Index	16-bit integer
83	VO44 Fault Index	16-bit integer
84	VO45 Fault Index	16-bit integer
85	VO46 Fault Index	16-bit integer
86	VO47 Fault Index	16-bit integer
87	VO48 Fault Index	16-bit integer
88	VO49 Fault Index	16-bit integer
89	VO50 Fault Index	16-bit integer
90	VO51 Fault Index	16-bit integer
91	VO52 Fault Index	16-bit integer
92	VO53 Fault Index	16-bit integer
93	VO54 Fault Index	16-bit integer
94	VO55 Fault Index	16-bit integer
95	VO56 Fault Index	16-bit integer
96	VO57 Fault Index	16-bit integer
97	VO58 Fault Index	16-bit integer
98	VO59 Fault Index	16-bit integer
99	VO60 Fault Index	16-bit integer
100	VO61 Fault Index	16-bit integer
101	VO62 Fault Index	16-bit integer
102	VO63 Fault Index	16-bit integer
103	VO64 Fault Index	16-bit integer
104–105	VO1 Complete Fault Code	32-bit integer

REG #	WORD NAME	DATA TYPE
106–107	VO2 Complete Fault Code	32-bit integer
108–109	VO3 Complete Fault Code	32-bit integer
110–111	VO4 Complete Fault Code	32-bit integer
112–113	VO5 Complete Fault Code	32-bit integer
114–115	VO6 Complete Fault Code	32-bit integer
116–117	VO7 Complete Fault Code	32-bit integer
118–119	VO8 Complete Fault Code	32-bit integer
120–121	VO9 Complete Fault Code	32-bit integer
122–123	VO10 Complete Fault Code	32-bit integer
124–125	VO11 Complete Fault Code	32-bit integer
126–127	VO12 Complete Fault Code	32-bit integer
128–129	VO13 Complete Fault Code	32-bit integer
130–131	VO14 Complete Fault Code	32-bit integer
132–133	VO15 Complete Fault Code	32-bit integer
134–135	VO16 Complete Fault Code	32-bit integer
136–137	VO17 Complete Fault Code	32-bit integer
138–139	VO18 Complete Fault Code	32-bit integer
140–141	VO19 Complete Fault Code	32-bit integer
142–143	VO20 Complete Fault Code	32-bit integer
144–145	VO21 Complete Fault Code	32-bit integer
146–147	VO22 Complete Fault Code	32-bit integer
148–149	VO23 Complete Fault Code	32-bit integer
150–151	VO24 Complete Fault Code	32-bit integer
152–153	VO25 Complete Fault Code	32-bit integer
154–155	VO26 Complete Fault Code	32-bit integer
156–157	VO27 Complete Fault Code	32-bit integer
158–159	VO28 Complete Fault Code	32-bit integer
160–161	VO29 Complete Fault Code	32-bit integer
162–163	VO30 Complete Fault Code	32-bit integer
164–165	VO31 Complete Fault Code	32-bit integer
166–167	VO32 Complete Fault Code	32-bit integer
168–169	VO33 Complete Fault Code	32-bit integer
170–171	VO34 Complete Fault Code	32-bit integer
172–173	VO35 Complete Fault Code	32-bit integer
174–175	VO36 Complete Fault Code	32-bit integer
176–177	VO37 Complete Fault Code	32-bit integer
178–179	VO38 Complete Fault Code	32-bit integer
180–181	VO39 Complete Fault Code	32-bit integer
182–183	VO40 Complete Fault Code	32-bit integer
184–185	VO41 Complete Fault Code	32-bit integer

REG #	WORD NAME	DATA TYPE
186–187	VO42 Complete Fault Code	32-bit integer
188–189	VO43 Complete Fault Code	32-bit integer
190–191	VO44 Complete Fault Code	32-bit integer
192–193	VO45 Complete Fault Code	32-bit integer
194–195	VO46 Complete Fault Code	32-bit integer
196–197	VO47 Complete Fault Code	32-bit integer
198–199	VO48 Complete Fault Code	32-bit integer
200–201	VO49 Complete Fault Code	32-bit integer
202–203	VO50 Complete Fault Code	32-bit integer
204–205	VO51 Complete Fault Code	32-bit integer
206–207	VO52 Complete Fault Code	32-bit integer
208–209	VO53 Complete Fault Code	32-bit integer
210–211	VO54 Complete Fault Code	32-bit integer
212–213	VO55 Complete Fault Code	32-bit integer
214–215	VO56 Complete Fault Code	32-bit integer
216–217	VO57 Complete Fault Code	32-bit integer
218–219	VO58 Complete Fault Code	32-bit integer
220–221	VO59 Complete Fault Code	32-bit integer
222–223	VO60 Complete Fault Code	32-bit integer
224–225	VO61 Complete Fault Code	32-bit integer
226–227	VO62 Complete Fault Code	32-bit integer
228–229	VO63 Complete Fault Code	32-bit integer
230–231	VO64 Complete Fault Code	32-bit integer
232–233	Fault #1 Time Stamp	32-bit integer
234–241	Fault #1 Name of I/O or System	2-word length + 12-ASCII characters
242	Fault #1 Error Code	16-bit integer
243	Fault #1 Advanced Error Code	16-bit integer
244	Fault #1 Error Message Index	16-bit integer
245–246	<i>reserved</i>	16-bit integer
247–248	Fault #2 Time Stamp	32-bit integer
249–256	Fault #2 Name of I/O or System	2-word length + 12-ASCII characters
257	Fault #2 Error Code	16-bit integer
258	Fault #2 Advanced Error Code	16-bit integer
259	Fault #2 Error Message Index	16-bit integer
260–261	<i>reserved</i>	16-bit integer
262–263	Fault #3 Time Stamp	32-bit integer
264–271	Fault #3 Name of I/O or System	2-word length + 12-ASCII characters
272	Fault #3 Error Code	16-bit integer
273	Fault #3 Advanced Error Code	16-bit integer
274	Fault #3 Error Message Index	16-bit integer

REG #	WORD NAME	DATA TYPE
275–276	<i>reserved</i>	16-bit integer
277–278	Fault #4 Time Stamp	32-bit integer
279–286	Fault #4 Name of I/O or System	2-word length + 12-ASCII characters
287	Fault #4 Error Code	16-bit integer
288	Fault #4 Advanced Error Code	16-bit integer
289	Fault #4 Error Message Index	16-bit integer
290–291	<i>reserved</i>	16-bit integer
292–293	Fault #5 Time Stamp	32-bit integer
294–301	Fault #5 Name of I/O or System	2-word length + 12-ASCII characters
302	Fault #5 Error Code	16-bit integer
303	Fault #5 Advanced Error Code	16-bit integer
304	Fault #5 Error Message Index	16-bit integer
305–306	<i>reserved</i>	16-bit integer
307–308	Fault #6 Time Stamp	32-bit integer
309–316	Fault #6 Name of I/O or System	2-word length + 12-ASCII characters
317	Fault #6 Error Code	16-bit integer
318	Fault #6 Advanced Error Code	16-bit integer
319	Fault #6 Error Message Index	16-bit integer
320–321	<i>reserved</i>	16-bit integer
322–323	Fault #7 Time Stamp	32-bit integer
324–331	Fault #7 Name of I/O or System	2-word length + 12-ASCII characters
332	Fault #7 Error Code	16-bit integer
333	Fault #7 Advanced Error Code	16-bit integer
334	Fault #7 Error Message Index	16-bit integer
335–336	<i>reserved</i>	16-bit integer
337–338	Fault #8 Time Stamp	32-bit integer
339–346	Fault #8 Name of I/O or System	2-word length + 12-ASCII characters
347	Fault #8 Error Code	16-bit integer
348	Fault #8 Advanced Error Code	16-bit integer
349	Fault #8 Error Message Index	16-bit integer
350–351	<i>reserved</i>	16-bit integer
352–353	Fault #9 Time Stamp	32-bit integer
354–361	Fault #9 Name of I/O or System	2-word length + 12-ASCII characters
362	Fault #9 Error Code	16-bit integer
363	Fault #9 Advanced Error Code	16-bit integer
364	Fault #9 Error Message Index	16-bit integer
365–366	<i>reserved</i>	16-bit integer
367–368	Fault #10 Time Stamp	32-bit integer
369–376	Fault #10 Name of I/O or System	2-word length + 12-ASCII characters
377	Fault #10 Error Code	16-bit integer

REG #	WORD NAME	DATA TYPE
378	Fault #10 Advanced Error Code	16-bit integer
379	Fault #10 Error Message Index	16-bit integer
380–381	<i>reserved</i>	16-bit integer
382–383	Seconds Since Boot	32-bit integer
384	Operating Mode	16-bit integer
385–394	ConfigName	2-word length + 16-ASCII characters
395–396	Config CRC	32-bit integer
397–899	<i>reserved</i>	16-bit integer
900	VO1 – VO16 (see <a href="#">Flags</a> on p. 143)	16-bit integer
901	VO17 – VO32 (see <a href="#">Flags</a> on p. 143)	16-bit integer
902	VO33 – VO48 (see <a href="#">Flags</a> on p. 143)	16-bit integer
903	VO49 – VO64 (see <a href="#">Flags</a> on p. 143)	16-bit integer
904	VO65 – VO80 (see <a href="#">Extended Flags</a> on p. 144)	16-bit integer
905	VO81 – VO96 (see <a href="#">Extended Flags</a> on p. 144)	16-bit integer
906	VO97 – VO112 (see <a href="#">Extended Flags</a> on p. 144)	16-bit integer
907	VO113 – VO128 (see <a href="#">Extended Flags</a> on p. 144)	16-bit integer
908	VO129 – VO144 (see <a href="#">Extended Flags</a> on p. 144)	16-bit integer
909	VO145 – VO160 (see <a href="#">Extended Flags</a> on p. 144)	16-bit integer
910	VO161 – VO176 (see <a href="#">Extended Flags</a> on p. 144)	16-bit integer
911	VO177 – VO192 (see <a href="#">Extended Flags</a> on p. 144)	16-bit integer
912	VO193 – VO208 (see <a href="#">Extended Flags</a> on p. 144)	16-bit integer
913	VO209 – VO224 (see <a href="#">Extended Flags</a> on p. 144)	16-bit integer
914	VO225 – VO240 (see <a href="#">Extended Flags</a> on p. 144)	16-bit integer
915	VO241 – VO256 (see <a href="#">Extended Flags</a> on p. 144)	16-bit integer
916	Fault bits for VO1 – VO16 (see <a href="#">Flags</a> on p. 143)	16-bit integer
917	Fault bits for VO17 – VO32 (see <a href="#">Flags</a> on p. 143)	16-bit integer
918	Fault bits for VO33 – VO48 (see <a href="#">Flags</a> on p. 143)	16-bit integer
919	Fault bits for VO49 – VO64 (see <a href="#">Flags</a> on p. 143)	16-bit integer
920	Fault bits for VO65 – VO80 (see <a href="#">Extended Flags</a> on p. 144)	16-bit integer
921	Fault bits for VO81 – VO96 (see <a href="#">Extended Flags</a> on p. 144)	16-bit integer
922	Fault bits for VO97 – VO112 (see <a href="#">Extended Flags</a> on p. 144)	16-bit integer
923	Fault bits for VO113 – VO128 (see <a href="#">Extended Flags</a> on p. 144)	16-bit integer
924	Fault bits for VO129 – VO144 (see <a href="#">Extended Flags</a> on p. 144)	16-bit integer
925	Fault bits for VO145 – VO160 (see <a href="#">Extended Flags</a> on p. 144)	16-bit integer
926	Fault bits for VO161 – VO176 (see <a href="#">Extended Flags</a> on p. 144)	16-bit integer
927	Fault bits for VO177 – VO192 (see <a href="#">Extended Flags</a> on p. 144)	16-bit integer
928	Fault bits for VO193 – VO208 (see <a href="#">Extended Flags</a> on p. 144)	16-bit integer
929	Fault bits for VO209 – VO224 (see <a href="#">Extended Flags</a> on p. 144)	16-bit integer
930	Fault bits for VO225 – VO240 (see <a href="#">Extended Flags</a> on p. 144)	16-bit integer
931	Fault bits for VO241 – VO256 (see <a href="#">Extended Flags</a> on p. 144)	16-bit integer

REG #	WORD NAME	DATA TYPE
932	Virtual Reset/Cancel Delay (1–16) Feedback [RCD Feedback Register Bits] (see <a href="#">Virtual Manual Reset and Cancel Delay (RCD) Sequence</a> on p. 38)	16-bit integer
933	<i>reserved</i>	16-bit integer
934	RCD Actuation Code Feedback [RCD Enable Feedback Register] (see <a href="#">Virtual Manual Reset and Cancel Delay (RCD) Sequence</a> on p. 38)	16-bit integer
935	VO1 Fault Index	16-bit integer
936	VO2 Fault Index	16-bit integer
937	VO3 Fault Index	16-bit integer
...	...	...
1190	VO256 Fault Index	16-bit integer
1191–1192	VO1 Complete Fault Code	32-bit integer
1193–1194	VO2 Complete Fault Code	32-bit integer
1195–1196	VO3 Complete Fault Code	32-bit integer
1197–1198	VO4 Complete Fault Code	32-bit integer
...	...	...
1701–1702	VO256 Complete Fault Code	32-bit integer
1703–1704	DCD System Status – Chain 1 Device Count	32-bit integer
1705–1706	DCD System Status – Chain 2 Device Count	32-bit integer
1707–1708	DCD System Status – Chain 1 Device On/Off Status	32-bit integer
1709–1710	DCD System Status – Chain 2 Device On/Off Status	32-bit integer
1711–1712	DCD System Status – Chain 1 Fault Status	32-bit integer
1713–1714	DCD System Status – Chain 2 Fault Status	32-bit integer
1715–1716	DCD System Status – Chain 1 Marginal Status	32-bit integer
1717–1718	DCD System Status – Chain 2 Marginal Status	32-bit integer
1719–1720	DCD System Status – Chain 1 Alert Status	32-bit integer
1721–1722	DCD System Status – Chain 2 Alert Status	32-bit integer
1723–1724	DCD System Status – Chain 1 Reset Status	32-bit integer
1725–1726	DCD System Status – Chain 2 Reset Status	32-bit integer
1727–1728	DCD System Status – Chain 1 Actuator Recognized	32-bit integer
1728–1730	DCD System Status – Chain 2 Actuator Recognized	32-bit integer
1731–1732	DCD System Status – Chain 1 System Status	32-bit integer
1733–1734	DCD System Status – Chain 2 System Status	32-bit integer
1735–1766	<i>reserved</i>	16-bit integer
1768	DCD Read Request Acknowledge	16-bit integer
1769	DCD Chain Requested Acknowledge	16-bit integer
1770	DCD Device Requested Acknowledge	16-bit integer
1771–1779	DCD Individual Device-Specific Data <sup>27</sup>	16-bit integer

<sup>27</sup> For conversion to Internal Temperature, Actuator Distance, and Supply Voltage, see [Temperature, Voltage, and Distance Conversion Information](#) on p. 162.

## 9.5.4 Inputs to Safety Controller (Outputs from PLC)

The Input registers are used to send information to the Safety Controller from the PLC. MSG (message) commands are used to Write (N11) to the Safety Controller.

Table 29: N11 REGS

REG #	WORD NAME	DATA TYPE
0–7	<i>reserved</i>	16-bit integer
8	Virtual Input On/Off (1–16)	16-bit integer
9	Virtual Input On/Off (17–32)	16-bit integer
10	Virtual Input On/Off (33–48)	16-bit integer
11	Virtual Input On/Off (49–64)	16-bit integer
12–15	<i>reserved</i>	16-bit integer
16	Virtual Reset/Cancel Delay (1–16) [RCD Register Bits] (see <a href="#">Virtual Manual Reset and Cancel Delay (RCD) Sequence</a> on p. 38)	16-bit integer
17	<i>reserved</i>	16-bit integer
18	RCD Actuation Code [RCD Enable Register] (see <a href="#">Virtual Manual Reset and Cancel Delay (RCD) Sequence</a> on p. 38)	16-bit integer
19	DCD Read Request	16-bit integer
20	DCD Chain Requested	16-bit integer
21	DCD Device Requested	16-bit integer

## 9.5.5 Flags

Registers 0 through 7, defined below, appear as the first 8 words in the N7 register map.

Table 30: Register #0, Virtual Output 1-16, Bit Position

Bit Position															
15	14	13	12	11	10	9	8	7	6	5	4	3	2	1	0
VO16	VO15	VO14	VO13	VO12	VO11	VO10	VO9	VO8	VO7	VO6	VO5	VO4	VO3	VO2	VO1

Table 31: Register #1, Virtual Output 17-32, Bit Position

Bit Position															
15	14	13	12	11	10	9	8	7	6	5	4	3	2	1	0
VO32	VO31	VO30	VO29	VO28	VO27	VO26	VO25	VO24	VO23	VO22	VO21	VO20	VO19	VO18	VO17

Table 32: Register #2, Virtual Output 33-48, Bit Position

Bit Position															
15	14	13	12	11	10	9	8	7	6	5	4	3	2	1	0
VO48	VO47	VO46	VO45	VO44	VO43	VO42	VO41	VO40	VO39	VO38	VO37	VO36	VO35	VO34	VO33

Table 33: Register #3, Virtual Output 49-64, Bit Position

Bit Position															
15	14	13	12	11	10	9	8	7	6	5	4	3	2	1	0
VO64	VO63	VO62	VO61	VO60	VO59	VO58	VO57	VO56	VO55	VO54	VO53	VO52	VO51	VO50	VO49

Table 34: Register #4, Fault Flag bits for Virtual Output 1-16, Bit Position

Note that not every Virtual Output has a defined Fault Flag.

Bit Position															
15	14	13	12	11	10	9	8	7	6	5	4	3	2	1	0
VO16	VO15	VO14	VO13	VO12	VO11	VO10	VO9	VO8	VO7	VO6	VO5	VO4	VO3	VO2	VO1

Table 35: Register #5, Fault Flag bits for Virtual Output 17-32 Fault Flag, Bit Position

Note that not every Virtual Output has a defined Fault Flag.

Bit Position															
15	14	13	12	11	10	9	8	7	6	5	4	3	2	1	0
VO32	VO31	VO30	VO29	VO28	VO27	VO26	VO25	VO24	VO23	VO22	VO21	VO20	VO19	VO18	VO17

Table 36: Register #6, Fault Flag bits for Virtual Output 33-48, Bit Position

Note that not every Virtual Output has a defined Fault Flag.

Bit Position															
15	14	13	12	11	10	9	8	7	6	5	4	3	2	1	0
VO48	VO47	VO46	VO45	VO44	VO43	VO42	VO41	VO40	VO39	VO38	VO37	VO36	VO35	VO34	VO33

Table 43: Table 37: Register #7, Fault Flag bits for Virtual Output 49-64, Bit Position

Note that not every Virtual Output has a defined Fault Flag.

Bit Position															
15	14	13	12	11	10	9	8	7	6	5	4	3	2	1	0
VO64	VO63	VO62	VO61	VO60	VO59	VO58	VO57	VO56	VO55	VO54	VO53	VO52	VO51	VO50	VO49

## 9.5.6 Extended Flags

All 256 Virtual Outputs can be accessed in a way similar to that seen in [Flags](#) on p. 143.

All 256 possible Virtual Outputs can be read as Registers 900-915.

All 256 possible Virtual Output Faults can be read as Registers 916-931.

## 9.6 PROFINET®

PROFINET<sup>®28</sup> is a data communication protocol for industrial automation and processes. PROFINET IO defines how controllers (IO controllers) and peripheral devices (IO devices) exchange data in real time.

BERNSTEIN Safety Controller supports PROFINET IO. The data communication protocol is TCP/IP; the data transmission medium is copper wire; the PROFINET conformance class is CC-A.<sup>29</sup>



**Note:** In this document, outputs from the Safety Controller device are referred to as "inputs" to the controller (PLC). Outputs from the controller (PLC) are referred to as "inputs" to the Safety Controller device.

### 9.6.1 PROFINET and the Safety Controllers

PROFINET real time data is sent and received via slots.



**Note:** The GSDML file is available for download at <http://www.BERNSTEIN.com>.

<sup>28</sup> PROFINET® is a registered trademark of PROFIBUS Nutzerorganisation e.V.

<sup>29</sup> CC-A ensures that the device has the minimum properties regarding functionality and interoperability.



## 9.6.2 General Station Description (GSD) File

The General Station Description (GSD) file contains module information, such as:

- Configuration data
- Data information (pass count, inspection status, etc.)
- Diagnostics

## 9.6.3 PROFINET IO Data Model

The PROFINET IO data model is based on the typical, expandable field device that has a backplane with slots. Modules and submodules have different functionalities.

Modules are plugged into slots; submodules are plugged into subslots. In the PROFINET IO data model, Slot 0 Subslot 1 is reserved for the Device Access Point (DAP) or network interface.

Both modules and submodules are used to control the type and volume of data that is sent to the controller (PLC).

- A submodule is typically designated as input type, output type, or combined input/output type
- An input submodule is used to send data to the controller (PLC)
- An output submodule is used to receive data from the controller (PLC)
- The combined input/output submodule simultaneously receives and sends data in both directions

## 9.6.4 Configuring the Safety Controller for a PROFINET IO Connection

1. Connect the Safety Controller to the PC via the SC-USB2 USB cable.
2. Open the BERNSTEIN Safety Controller Software, and click the **Industrial Ethernet** tab.
3. From the dropdown list on the left, select **Profinet**.
4. Click  to add information to the PROFINET Submodules.  
**Auto Configure** can assist in this task.
5. Provide the appropriate password to change the configuration and network settings for the Safety Controller.
6. Make sure the Safety Controller has a valid and confirmed configuration file.



**Note:** If a Virtual Reset or Cancel Delay is used, an Actuation Code must be created in **Network Settings**. Then the code must be sent to the Safety Controller using **Send** in **Network Settings**.

## 9.6.5 Description of Modules

Table 38: Assignment of Slots

In this table, the I/O direction is from the point of view of the PLC.

Slot	Module Function	I/O	Module Name	Module Size (Bytes)
1	User Defined Status Bits (0–31)	In	4 Status Bytes, Bits 0..31_1	4
2	User Defined Status Bits (32–63)	In	4 Status Bytes, Bits 0..31_2	4
3	Safety Controller Fault Bits (0–31)	In	4 Status Bytes, Bits 0..31_3	4
4	Safety Controller Fault Bits (32–63)	In	4 Status Bytes, Bits 0..31_4	4
5	Safety Controller Input Status Bits (0–31)	In	4 Status Bytes, Bits 0..31_5	4
6	Safety Controller Input Status Bits (32–63)	In	4 Status Bytes, Bits 0..31_6	4
7	Safety Controller Input Status Bits (64–95)	In	4 Status Bytes, Bits 0..31_7	4
8	Safety Controller Input Status Bits (96–127)	In	4 Status Bytes, Bits 0..31_8	4
9	Safety Controller Input Status Bits (128–159)	In	4 Status Bytes, Bits 0..31_9	4
10	Safety Controller Output Status Bits (0–31)	In	4 Status Bytes, Bits 0..31_10	4

Slot	Module Function	I/O	Module Name	Module Size (Bytes)
11	Safety Controller Output Status Bits (32–63)	In	4 Status Bytes, Bits 0..31_11	4
12	Safety Controller Output Status Bits (64–95)	In	4 Status Bytes, Bits 0..31_12	4
13	Virtual I/O (On/Off/Mute Enable) Bits (0–63)	Out	8 Bytes Virtual On/Off/ME Data_1	8
14	Virtual Reset, Cancel Delay Bits (0–16)	Out	2 Bytes RCD Data_1	2
15	Reset, Cancel Delay Actuation Code	Out	2 Byte RCD Actuation Code_1	2
16	Virtual Reset, Cancel Delay Bits (0–16) Feedback	In	RCD Data Feedback Register_1	2
17	Reset, Cancel Delay Actuation Code Feedback	In	RCD Passcode Feedback Register_1	2
18 <sup>30</sup>	Fault Log	In	Fault Log Buffer Module	300
19 <sup>30</sup>	System Information	In	System Information Module	30
20	DCD Status	In	DCD Status Information Module	128
21	DCD Individual Device Information	In/Out	DCD Individual Status Information Module	24 In/6 Out

## User Defined Status Bits

The first two slots are always filled with User Defined Status Bit modules. These modules include 64 bits worth of virtual status output information of any type.

Table 39: User Defined Status Bits (0–31) Module (Ident 0x100) [fixed in Slot 1]

PLC Input Data Name	Input Data Type	PLC Output Data Name	Output Data Type
User-Defined Status bits 0–7	Byte	Not applicable	Not applicable
User-Defined Status bits 8–15	Byte		
User-Defined Status bits 16–23	Byte		
User-Defined Status bits 24–31	Byte		

Table 40: User Defined Status Bits (32–63) Module (Ident 0x100) [fixed in Slot 2]

PLC Input Data Name	Input Data Type	PLC Output Data Name	Output Data Type
User-Defined Status bits 32–39	Byte	Not applicable	Not applicable
User-Defined Status bits 40–47	Byte		
User-Defined Status bits 48–55	Byte		
User-Defined Status bits 56–63	Byte		

<sup>30</sup> The Fault Log and System Information Modules are not used by the default connection.

## Fault Bits

Slots 3 and 4 are always filled with 64-bits of Fault type virtual status output information from the Safety Controller.

Table 41: Safety Controller Fault Bits (0–31) Module (Ident 0x100) [fixed in Slot 3]

PLC Input Data Name	Input Data Type	PLC Output Data Name	Output Data Type
Fault bits 0–7	Byte	Not applicable	Not applicable
Fault bits 8–15	Byte		
Fault bits 16–23	Byte		
Fault bits 24–31	Byte		

Table 42: Safety Controller Fault Bits (32–63) Module (Ident 0x100) [fixed in Slot 4]

PLC Input Data Name	Input Data Type	PLC Output Data Name	Output Data Type
Fault bits 32–39	Byte	Not applicable	Not applicable
Fault bits 40–47	Byte		
Fault bits 48–55	Byte		
Fault bits 56–63	Byte		

## Input Status Bits

Slots 5 through 9 are always reserved for 160 bits of Safety Controller input information. An expandable (XS26) safety controller might have up to 154 inputs, if all of eight possible expansion cards were used as 16 channel inputs (in addition to the 26 inputs built into the Base Controller).

Table 43: Safety Controller Input Status Bits (0–31) Module (Ident 0x100) [fixed in Slot 5]

PLC Input Data Name	Input Data Type	PLC Output Data Name	Output Data Type
Input Status bits 0–7	Byte	Not applicable	Not applicable
Input Status bits 8–15	Byte		
Input Status bits 16–23	Byte		
Input Status bits 24–31	Byte		

Table 44: Safety Controller Input Status Bits (32–63) Module (Ident 0x100) [fixed in Slot 6]

PLC Input Data Name	Input Data Type	PLC Output Data Name	Output Data Type
Input Status bits 32–39	Byte	Not applicable	Not applicable
Input Status bits 40–47	Byte		
Input Status bits 48–55	Byte		
Input Status bits 56–63	Byte		

Table 45: Safety Controller Input Status Bits (64–95) Module (Ident 0x100) [fixed in Slot 7]

PLC Input Data Name	Input Data Type	PLC Output Data Name	Output Data Type
Input Status bits 64–71	Byte	Not applicable	Not applicable
Input Status bits 72–79	Byte		
Input Status bits 80–87	Byte		
Input Status bits 88–95	Byte		

Table 46: Safety Controller Input Status Bits (96–127) Module (Ident 0x100) [fixed in Slot 8]

PLC Input Data Name	Input Data Type	PLC Output Data Name	Output Data Type
Input Status bits 96–103	Byte	Not applicable	Not applicable
Input Status bits 104–111	Byte		
Input Status bits 112–119	Byte		
Input Status bits 120–127	Byte		

Table 47: Safety Controller Input Status Bits (128–159) Module (Ident 0x100) [fixed in Slot 9]

PLC Input Data Name	Input Data Type	PLC Output Data Name	Output Data Type
Input Status bits 128–135	Byte	Not applicable	Not applicable
Input Status bits 136–143	Byte		
Input Status bits 144–151	Byte		
Input Status bits 152–159	Byte		

## Output Status Bits

Slots 10 through 12 are reserved for 96 safety controller output type virtual status output bits.

Table 48: Safety Controller Output Status Bits (0–31) Module (Ident 0x100) [fixed in Slot 10]

PLC Input Data Name	Input Data Type	PLC Output Data Name	Output Data Type
Output Status bits 0–7	Byte	Not applicable	Not applicable
Output Status bits 8–15	Byte		
Output Status bits 16–23	Byte		
Output Status bits 24–31	Byte		

Table 49: Safety Controller Output Status Bits (32–63) Module (Ident 0x100) [fixed in Slot 11]

PLC Input Data Name	Input Data Type	PLC Output Data Name	Output Data Type
Output Status bits 32–39	Byte	Not applicable	Not applicable
Output Status bits 40–47	Byte		
Output Status bits 48–55	Byte		
Output Status bits 56–63	Byte		

Table 50: Safety Controller Output Status Bits (64–95) Module (Ident 0x100) [fixed in Slot 12]

PLC Input Data Name	Input Data Type	PLC Output Data Name	Output Data Type
Output Status bits 64–71	Byte	Not applicable	Not applicable
Output Status bits 72–79	Byte		
Output Status bits 80–87	Byte		
Output Status bits 88–95	Byte		

### Virtual On, Off, Mute Enable Bits

Slot 13 is filled with 64 virtual non-safety inputs, to be used as virtual on/off inputs (to the Safety Controller) or virtual mute enable inputs (to the Safety Controller).

Table 51: Virtual On/Off/Mute Enable Bits (0–63) Module (Ident 0x200) [fixed in Slot 13]

PLC Input Data Name	Input Data Type	PLC Output Data Name	Output Data Type
Not applicable	Not applicable	Virtual On/Off/ME bits 0–7	Byte
		Virtual On/Off/ME bits 8–15	Byte
		Virtual On/Off/ME bits 16–23	Byte
		Virtual On/Off/ME bits 24–31	Byte
		Virtual On/Off/ME bits 32–39	Byte
		Virtual On/Off/ME bits 40–47	Byte
		Virtual On/Off/ME bits 48–55	Byte
		Virtual On/Off/ME bits 56–63	Byte

### Virtual Reset, Cancel Delay (VRCD) Bits

16 virtual non-safety inputs can be found in slot 14, to be used in the virtual reset, cancel delay sequence.

See [Virtual Manual Reset and Cancel Delay \(RCD\) Sequence](#) on p. 38.

Table 52: Virtual Reset, Cancel Delay Bits (0–63) Module (Ident 0x300) [fixed in Slot 14]

PLC Input Data Name	Input Data Type	PLC Output Data Name	Output Data Type
Not applicable	Not applicable	VRCD bits 0-7	Byte
		VRCD bits 8-15	Byte

## Reset, Cancel Delay (RCD) 16-bit Actuation Code

Slot 15 contains the RCD Actuation Code, an important code word used in the virtual reset, cancel delay sequence.

See [Virtual Manual Reset and Cancel Delay \(RCD\) Sequence](#) on p. 38.

Table 53: Reset, Cancel Delay Actuation Code Module (Ident 0x301) [fixed in Slot 15]

PLC Input Data Name	Input Data Type	PLC Output Data Name	Output Data Type
Not applicable	Not applicable	Reset, Cancel Delay Actuation Code	Unsigned 16

## Virtual Reset, Cancel Delay Feedback Bits

Slot 16 includes feedback bits for the 16 virtual non-safety inputs found in slot 14. They are used in the virtual reset, cancel delay sequence.

See [Virtual Manual Reset and Cancel Delay \(RCD\) Sequence](#) on p. 38.

Table 54: Virtual Reset, Cancel Delay Bits (0–63) Module (Ident 0x400) [fixed in Slot 16]

PLC Input Data Name	Input Data Type	PLC Output Data Name	Output Data Type
VRCD Feedback bits 0–7	Byte	Not applicable	Not applicable
VRCD Feedback bits 8–15	Byte		

## Reset, Cancel Delay 16-bit Actuation Code Feedback

Slot 17 includes the RCD Actuation Code feedback value, an important code word used in the virtual reset, cancel delay sequence.

See [Virtual Manual Reset and Cancel Delay \(RCD\) Sequence](#) on p. 38.

Table 55: Reset, Cancel Delay Actuation Code Module (Ident 0x401) [fixed in Slot 17]

PLC Input Data Name	Input Data Type	PLC Output Data Name	Output Data Type
Reset, Cancel Delay Actuation Code Feedback	Unsigned 16	Not applicable	Not applicable

## Fault Log Entries

Slot 18 can be filled with the optional Fault Log Buffer Module.

Table 56: Safety Controller Fault Log Buffer Module (Ident 0x500) [optional; fixed in Slot 18 when used]

PLC Input Data Name	Input Data Type	PLC Output Data Name	Output Data Type
Fault Log entry 1 (most recent)	15 words	Not applicable	Not applicable
Fault Log entry 2	15 words		
Fault Log entry 3	15 words		
Fault Log entry 4	15 words		
Fault Log entry 5	15 words		
Fault Log entry 6	15 words		
Fault Log entry 7	15 words		
Fault Log entry 8	15 words		
Fault Log entry 9	15 words		
Fault Log entry 10 (oldest)	15 words		

Fault Log Entry	Type	Length (Words)
Timestamp	UDINT	2
Name Length	DWORD	2
Name String	String	6
Error Code	WORD	1
Advanced Error Code	WORD	1
Error Index Message	WORD	1
<i>reserved</i>	WORD	2

### Fault Time Stamp

The relative time, in seconds, when the fault occurred. As measured from time 0, which is the last time the Safety Controller was powered up.

### Name Length

The number of ASCII characters in the "Name String".

### Name String

An ASCII-string describing the source of the fault.

### Error Code, Advanced Error Code, Error Index Message

The Error Code and the Advanced Error Code, taken together, form the Safety Controller Fault Code. The format for the Fault Code is `Error Code 'dot' Advanced Error Code`. For example, a Safety Controller Fault Code of 2.1 is represented by an Error Code of 2 and an Advanced Error Code of 1. The Error Message Index value is the Error Code and the Advanced Error Code together, and includes a leading zero with the Advanced Error Code, if necessary. For example, a Safety Controller Fault Code of 2.1 is represented by an Error Message Index of 201. The Error Message Index value is a convenient way to get the complete Fault Code while only reading a single 16-bit register.

## System Information Buffer

Slot 19 can be filled with the optional System Information Buffer Module.

Table 57: Safety Controller System Information Buffer Module (Ident 0x600) [optional; fixed in Slot 19 when used]

PLC Input Data Name	Input Data Type	PLC Output Data Name	Output Data Type
System Information Buffer	30 words	Not applicable	Not applicable

System Information Buffer	Type	Length (Words)
Seconds Since Boot	UDINT	2
Operating Mode	WORD	1
Length of Config Name	DWORD	2
Config Name	String	8
Config CRC	WORD	2

### Seconds Since Boot

A 32-bit integer representation of the number of seconds since powering up the safety controller.

### Operating Mode

The current operational state of the safety controller.

Operating Mode Value	Description
1 (0x01)	Normal Operating Mode (including I/O faults, if present)
2 (0x02)	Configuration Mode
4 (0x04)	System Lockout
65 (0x41)	Waiting for System Reset/Exiting Configuration Mode
129 (0x81)	Entering Configuration Mode

### Length of Config Name

The number of ASCII characters in the "Config Name".

### Config Name

An ASCII-string describing the source of the fault.

### Config CRC

The Cyclic Redundancy Check (CRC) value for the current Safety Controller configuration.



## DCD Status Information Module

Slot 20 can be filled with the optional DCD Status Information Module.

PLC Input Data Name	Input Data Type	PLC Output Data Name	Output Data Type
DCD System Status – Chain 1 Device Count	Unsigned 32	Not applicable	Unsigned 16
DCD System Status – Chain 2 Device Count	Unsigned 32		
DCD System Status – Chain 1 Device On/Off Status	Unsigned 32		
DCD System Status – Chain 2 Device On/Off Status	Unsigned 32		
DCD System Status – Chain 1 Fault Status	Unsigned 32		
DCD System Status – Chain 2 Fault Status	Unsigned 32		
DCD System Status – Chain 1 Marginal Status	Unsigned 32		
DCD System Status – Chain 2 Marginal Status	Unsigned 32		
DCD System Status – Chain 1 Alert Status	Unsigned 32		
DCD System Status – Chain 2 Alert Status	Unsigned 32		
DCD System Status – Chain 1 Reset Status	Unsigned 32		
DCD System Status – Chain 2 Reset Status	Unsigned 32		
DCD System Status – Chain 1 Actuator Recognized	Unsigned 32		
DCD System Status – Chain 2 Actuator Recognized	Unsigned 32		
DCD System Status – Chain 1 System Status	Unsigned 32		
DCD System Status – Chain 2 System Status	Unsigned 32		
<i>64 bytes reserved</i>	Byte		

## DCD Individual Device Information Module

Slot 21 can be filled with the optional DCD Individual Device Information Module.

PLC Input Data Name	Input Data Type	PLC Output Data Name	Output Data Type
DCD Read Request Acknowledge	Unsigned 16	DCD Read Request	Unsigned 16
DCD Chain Requested Acknowledge	Unsigned 16	DCD Chain Requested	Unsigned 16
DCD Device Requested Acknowledge	Unsigned 16	DCD Device Requested	Unsigned 16
DCD Individual Device-Specific Data (18 Bytes) <sup>31</sup>	Byte		

### 9.6.6 Configuration Instructions

#### Installing the GSD File

Use these instructions to install the GSD file in the Siemens TIA Portal (v13) software. Use these instructions as a basis for installing the GSD file in another controller (PLC).

1. Download the GSD file from [www.bernstein.eu](http://www.bernstein.eu).
2. Start the Siemens TIA Portal (v13) software.
3. Click **Open existing project**.
4. Select a project and open it.
5. Click **Devices & networks** after the project has been uploaded.

<sup>31</sup> For conversion to Internal Temperature, Actuator Distance, and Supply Voltage, see [Temperature, Voltage, and Distance Conversion Information](#) on p. 162.

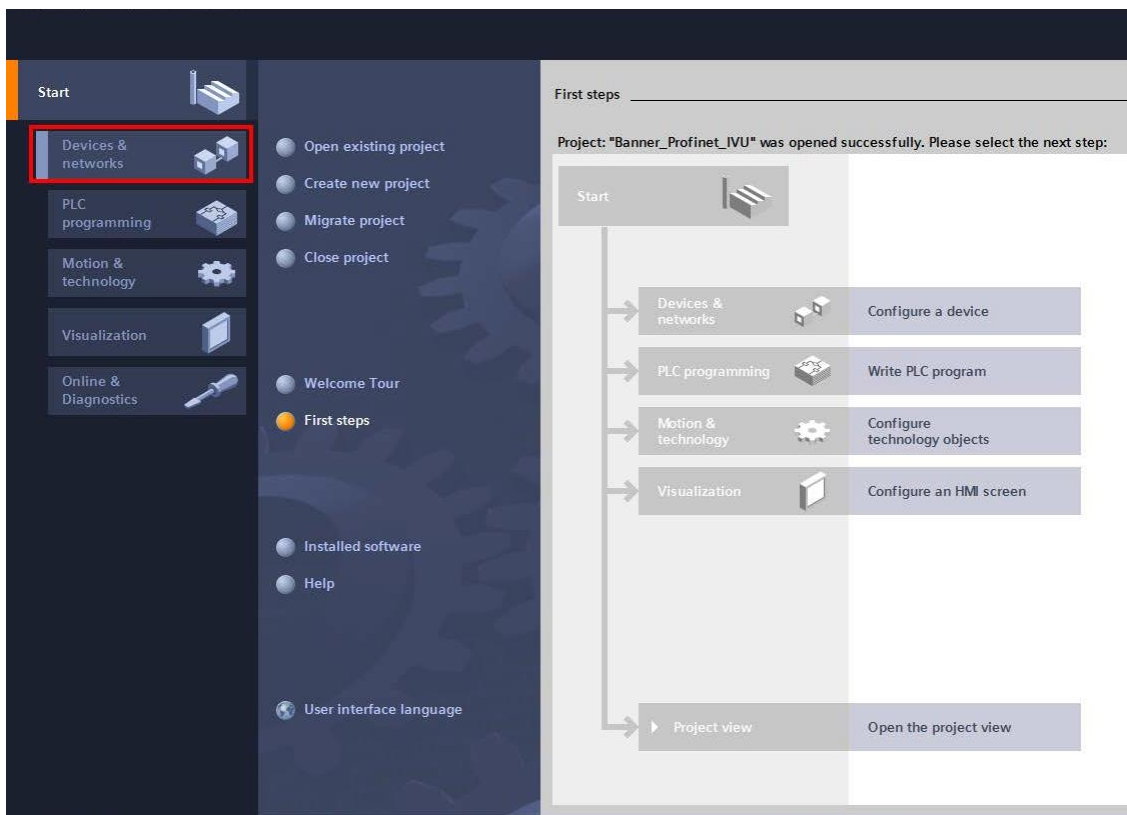

Figure 104: TIA - Devices and Networks

6. Click **Configure networks**.



Figure 105: TIA - Configure Networks

**Network view** displays.

7. Click **Options** and select **Manage general station description file (GSD)**.

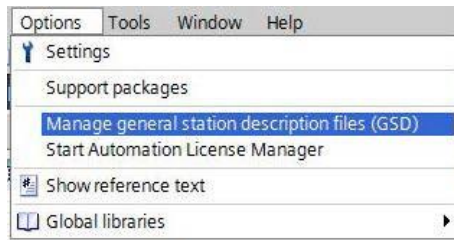

Figure 106: TIA - Options—Install the GSD

The **Install general station description file** window opens.

8. Click the browse button (...) to the right of the **Source path** field.

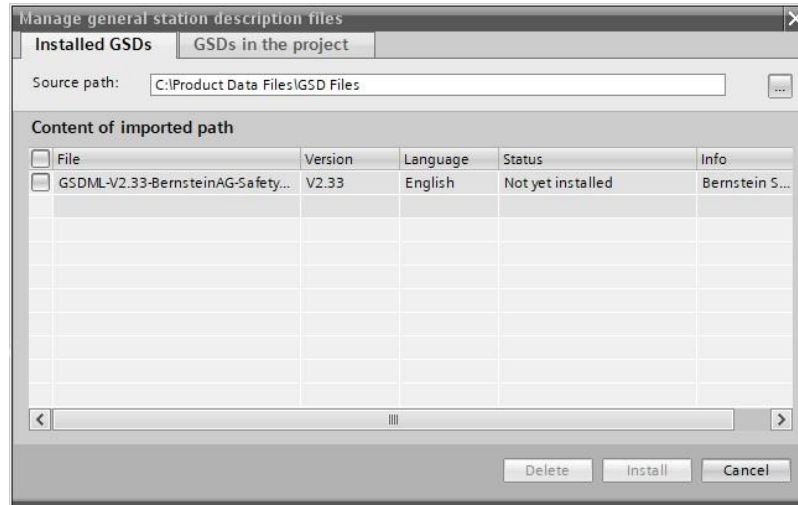

Figure 107: TIA - Manage GSD Files

9. Navigate to the location the Safety Controller GSD file was downloaded to.
10. Select the Safety Controller GSD file.
11. Click **Install**.

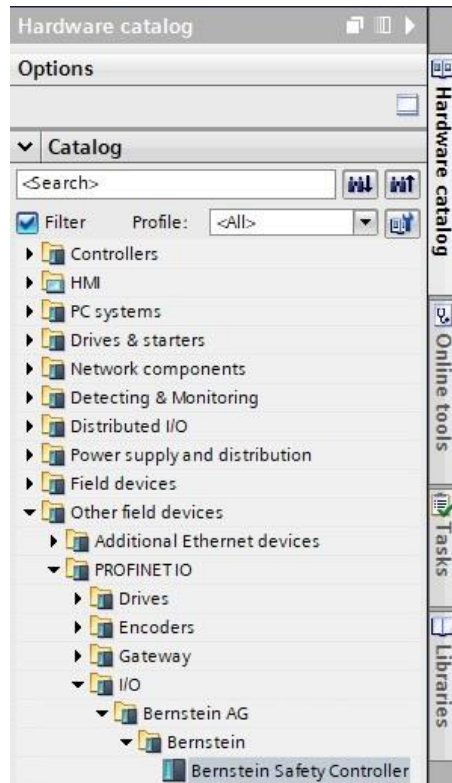

Figure 108: TIA - Hardware Catalog

The system installs the Safety Controller GSD file and places it in the **Hardware catalog**. In the above example, the Safety Controller GSD file is located under **Other field devices > PROFINET IO > I/O > BERNSTEIN AG > BERNSTEIN**.



**Note:** If the Safety Controller GSD file does not install properly, save the log and contact Bernstein AG

## Changing the Device IP Address

Use these instructions to change the IP address of the Safety Controller device, using the Siemens TIA Portal (v13) software. Use these instructions as a basis if you are using another controller (PLC).

1. Start the Siemens TIA Portal (v13) software.
2. Click **Open existing project**.
3. Select a project and open it.
4. Click **Devices & networks** after the project has been uploaded to go to **Network view**.

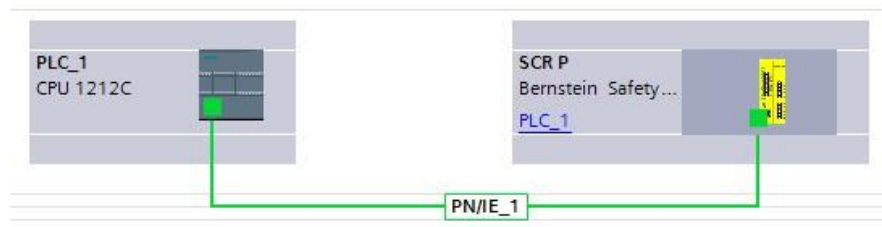

Figure 109: TIA - Network View

**Network View** displays.

5. Double-click on the Safety Controller icon to open the **Device view**.

6. Click on the Safety Controller icon in the graphic area of the **Device view** to open the **Module properties** window. The module can now be configured.
7. Click **Properties**.
8. Click **General**.
9. Select **PROFINET interface > Ethernet addresses**.

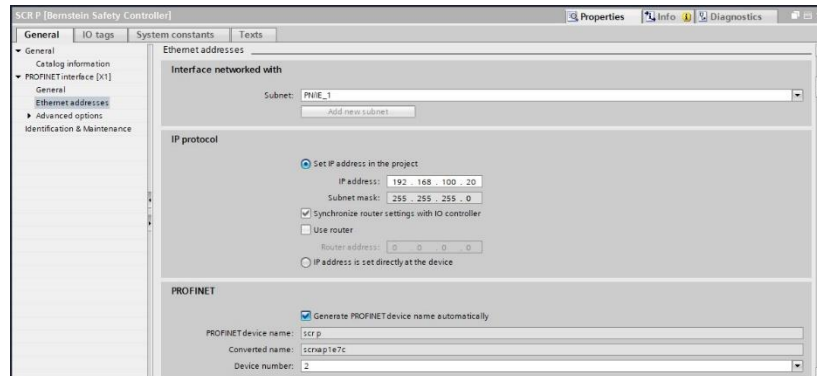

Figure 110: TIA - Ethernet Addresses

10. Select **Set IP address in the project**.

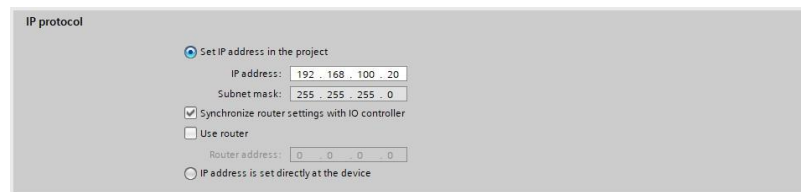

Figure 111: TIA - Set IP Address

The project sets the IP address of the device.

11. Enter the IP address.
12. Right-click on the device icon and select **Online & diagnostics**.

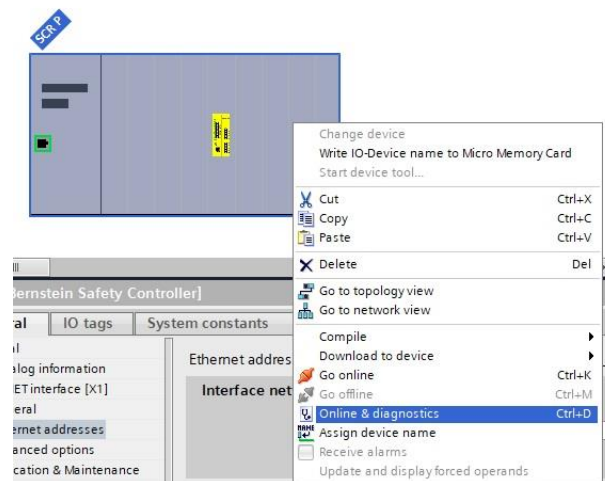

Figure 112: TIA - Select Online & Diagnostics

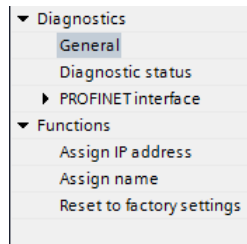

Figure 113: TIA - Online & Diagnostics

The **Online & diagnostics** window displays.

13. Select **Assign IP address** under **Functions**.
14. Click **Accessible devices**.

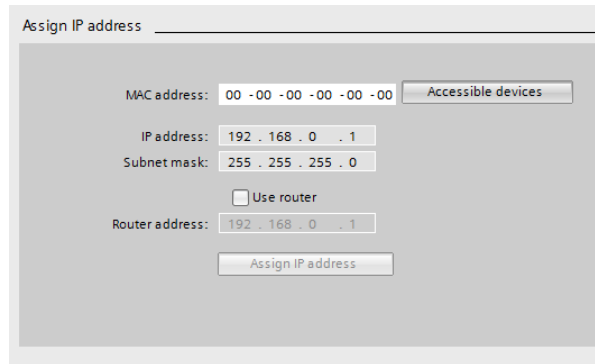

Figure 114: TIA - Assign IP Address—Accessible Devices

The **Select device** window searches the network for available devices.

15. Determine the device to be adjusted via the MAC address and select it.
16. Click **Apply**.

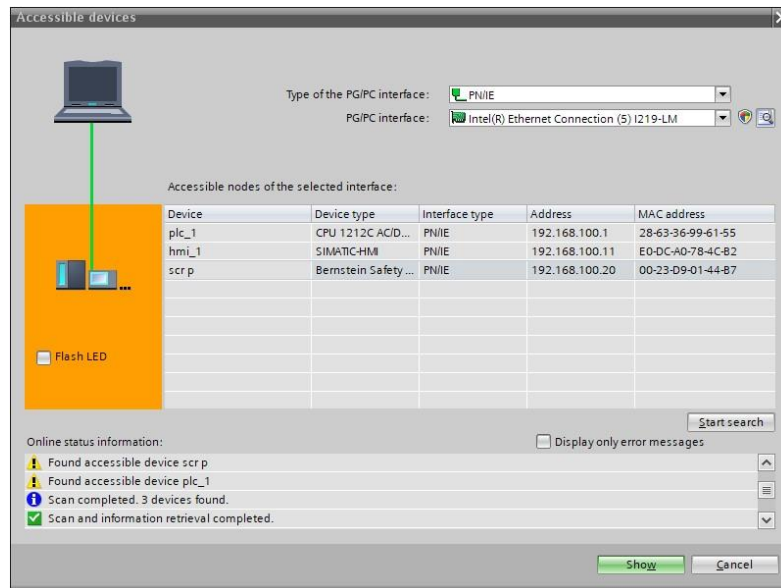

Figure 115: TIA - Select the Device and Apply Changes

The IP address for the device is updated.

17. Click **Assign IP address** to complete the step. This step is completed for every device.



**Note:** PROFINET devices commonly lack an IP address on startup (IP address = all zeros). However, Safety Controller devices require an IP address to connect to BERNSTEIN Safety Controller to set the device configuration.

By default, each camera shipped from the factory is assigned the IP address 192.168.0.128. The default address can be changed using BERNSTEIN Safety Controller.

Immediately after the PROFINET protocol has been enabled in the camera, but before the PLC discovers and connects to the camera, the camera will retain its IP address. After the PLC discovers and connects to the camera, the behavior of the IP address depends on how the PLC was configured to assign the camera IP address. Two configuration options are available.

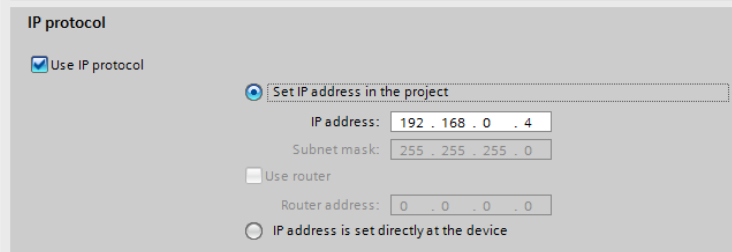

Figure 116: TIA - Siemens TIA Portal (v13): IP Protocol Options

- The IP address is set in the project: If the PLC is told to assign the camera IP address (for example, using the **Set IP address in the project** option in Siemens TIA Portal), the camera receives the specified address, but only after the program has been loaded into the PLC and is running.

If the camera is restarted after it was discovered and configured by the PLC, the camera has an IP address of 0.0.0.0 until the PLC discovers it and assigns it the specified address again.

When the camera has no IP address assigned, it is still possible to assign an IP address to the camera using BERNSTEIN Safety Controller. However, if this address is different than what is specified in the PLC, the camera reverts to the address specified in the PLC when the PLC becomes active again.

- The IP address is set at the device: If the PLC is told that the camera IP address is configured at the device (for example, using the **IP address is set directly at the device** option in Siemens TIA Portal), the camera always retains the IP address that was assigned to through BERNSTEIN Safety Controller.

These configuration options conform to the PROFINET standard.

## Changing the Device Name

Use these instructions to change the name of the Safety Controller device, using the Siemens TIA Portal (v13) software. Use these instructions as a basis if you are using another controller (PLC).

1. Open a project and click on **Devices & networks** to go to the **Network view**.

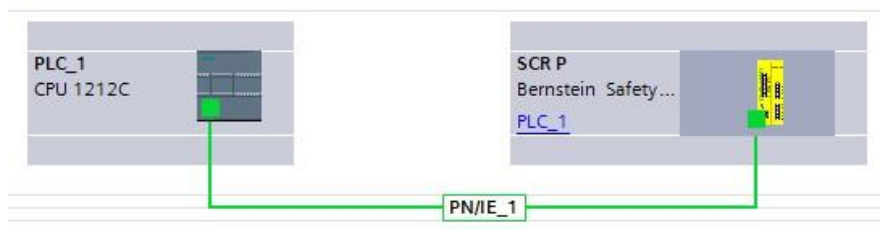

Figure 117: TIA - Network View

**Network view** displays.

2. Right-click on the Safety Controller icon and select **Assign device name**.



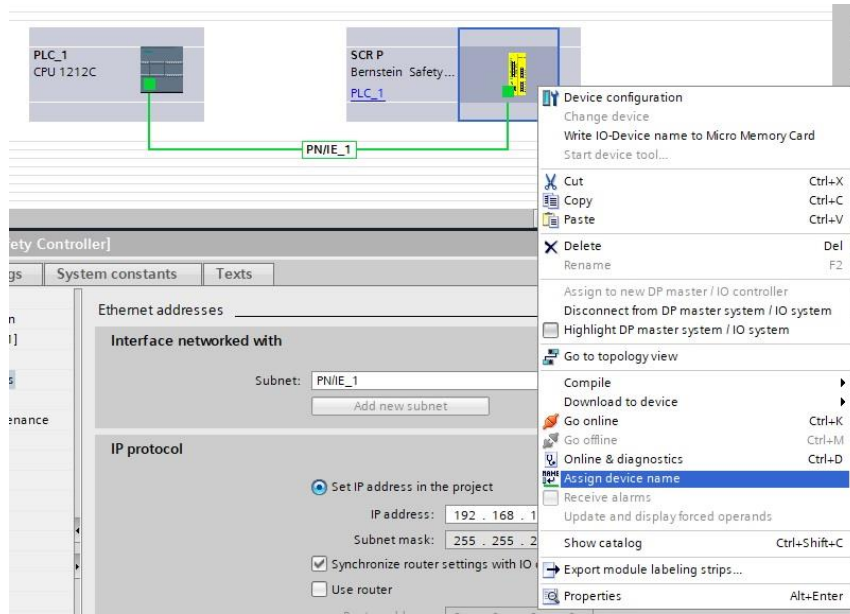

Figure 118: TIA - Ethernet Addresses

The **Assign PROFINET device name** window displays, and the software searches for devices of the same type.

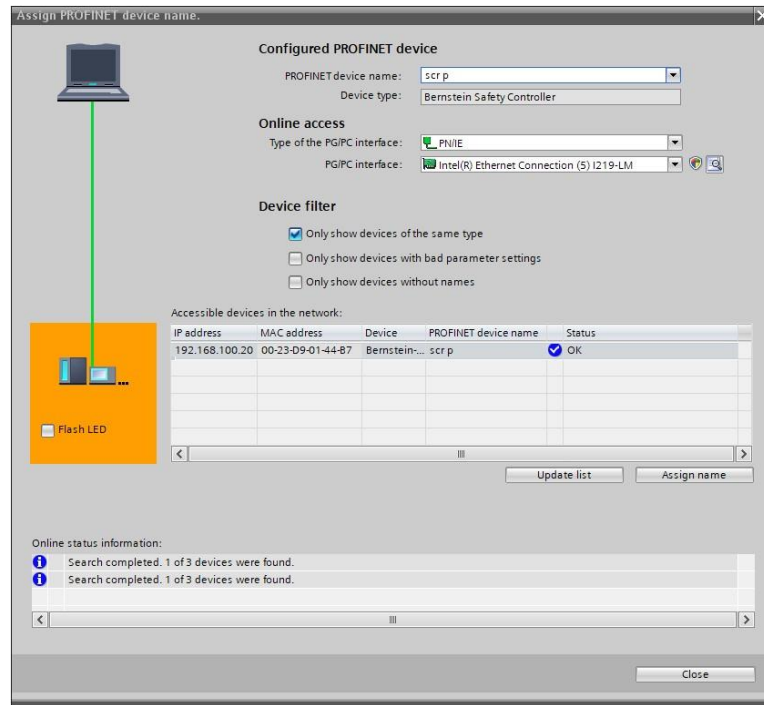

Figure 119: TIA - Ethernet Addresses

3. Enter the desired name in the **PROFINET device name** field.



**Note:** Each name can be used only once.

4. Click **Assign name**.  
The device now has a PROFINET name.

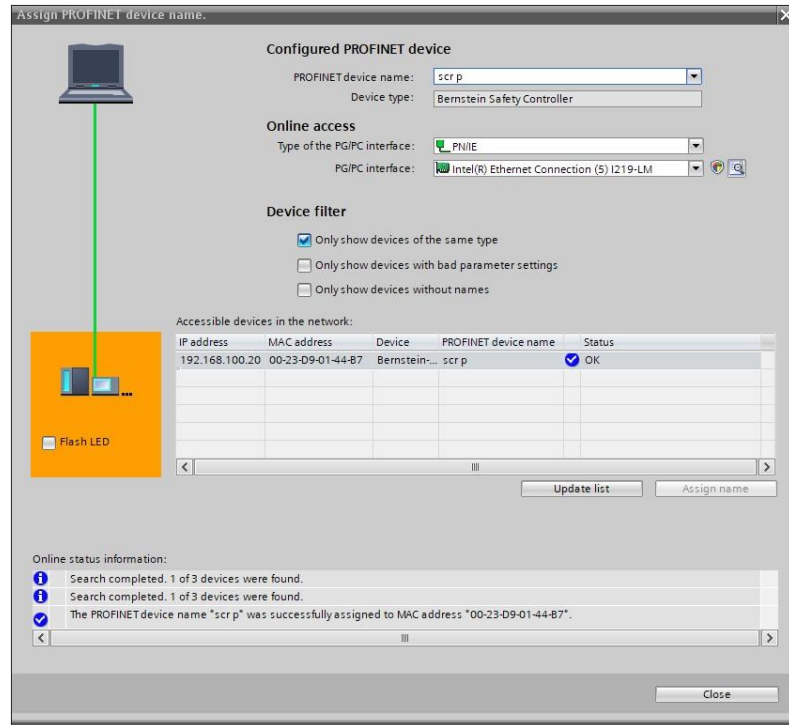

Figure 120: TIA - Ethernet Addresses

## 9.7 Temperature, Voltage, and Distance Conversion Information

Download an AOI from [www.bernstein.eu](http://www.bernstein.eu) to insert into the PLC program to perform the conversions from the obtained values to the real values.

### 9.7.1 Supply Voltage

To obtain the actual voltage reading from the ADC value sent to the PLC, multiply the ADC value by 0.1835.

$$\text{Supply Voltage} = \text{ADC Value} \times 0.1835$$

### 9.7.2 Internal Temperature

First, shift the ADC value left by 2 bits. Then, convert the binary reading into a number. If the number matches an ADC value in the following table, read the temperature. If the number is between the readings in the table, use the following formula to obtain the actual temperature.

Table 58: Temperature

$$\text{Internal Temperature} = ((A-L) / (H-L)) \times 5 + T$$

- A**  
the ADC Value obtained from the controller
- L**  
the ADC value on the lookup table less than or equal to A
- H**  
the ADC value on the lookup table greater than A
- T**  
the temperature associated with the L value

ADC Reading	Temperature (°C)
41	-40
54	-35
69	-30
88	-25
110	-20
136	-15
165	-10
199	-5
237	0
278	5
321	10
367	15
414	20
461	25
508	30
554	35
598	40
640	45
679	50
715	55
748	60
778	65
804	70
829	75
850	80
869	85
886	90
901	95
914	100
926	105
936	110

### 9.7.3 Actuator Distance

Convert the binary reading into a number. If the number matches an ADC value in the following table, read the distance. If the number is between the readings in the table, use the following formula to obtain the actual distance.

Table 59: Distance

$$\text{Actuator Distance} = ((A-L) / (H-L)) + D$$

**A**

the ADC Value obtained from the controller

**L**

the ADC value on the lookup table less than or equal to A

**H**

the ADC value on the lookup table greater than A

**D**

the distance associated with the L value

ADC Reading	Distance (mm)
<62	<7
62	7
65	8
77	9
110	10
133	11
148	12
158	13
163	14
169	15
172	16
176	17
180	18
>180	>18

# 10 System Checkout

## 10.1 Schedule of Required Checkouts

Verifying the configuration and proper functioning of the Safety Controller includes checking each safety and non-safety input device, along with each output device. As the inputs are individually switched from the Run state to the Stop state, the safety outputs must be validated that they turn On and Off as expected.



**WARNING: Do Not Use Machine Until System Is Working Properly**

**If all of these checks cannot be verified, do not attempt to use the safety system** that includes the Bernstein device and the guarded machine until the defect or problem has been corrected. **Attempts to use the guarded machine under such conditions could result in serious injury or death.**

A comprehensive test must be used to verify the operation of the Safety Controller and the functionality of the intended configuration. [Initial Setup, Commissioning, and Periodic Checkout Procedures](#) on p. 166 is intended to assist in developing a customized (configuration-specific) checklist for each application. This customized checklist must be made available to maintenance personnel for commissioning and periodic checkouts. A similar, simplified daily checkout checklist should be made for the operator (or Designated Person<sup>32</sup>). It is highly recommended to have copies of the wiring and logic diagrams and the configuration summary available to assist in the checkout procedures.



**WARNING:**

- **Perform Periodic Checkouts**
- Failure to perform these checks could create a dangerous situation that could result in serious injury or death.
- The appropriate personnel must perform the commissioning, periodic, and daily safety system checks at the suggested times to ensure that the safety system is operating as intended.

**Commissioning Checkout:** A Qualified Person<sup>32</sup> must perform a safety system commissioning procedure before the safeguarded machine application is placed into service and after each Safety Controller configuration is created or modified.

**Periodic (Semi-Annual) Checkout:** A Qualified Person<sup>32</sup> must also perform a safety system re-commissioning semi-annually (every 6 months) or at periodic intervals based on the appropriate local or national regulations.

**Daily Operational Checks:** A Designated Person<sup>32</sup> must also check the effectiveness of the risk reduction measures, per the device manufacturers' recommendation, each day that the safeguarded machine is in service.



**WARNING: Before Applying Power to the Machine**

Verify that the guarded area is clear of personnel and unwanted materials (such as tools) before applying power to the guarded machine. **Failure to follow these instructions could result in serious injury or death.**

## 10.2 Commissioning Checkout Procedure

**Before proceeding, verify that:**

- All solid state and relay output terminals of the complete Safety Controller system are not connected to the machine. Disconnecting all of the Safety Controller's safety output plug-on terminals is recommended.
- Power has been removed from the machine, and no power is available to the machine controls or actuators

Permanent connections are made at a later point.

### 10.2.1 Verifying System Operation

**The commissioning checkout procedure must be performed by a Qualified Person<sup>33</sup>. It must be performed only after configuring the Safety Controller and after properly installing and configuring the safety systems and safeguarding devices connected to its inputs (see [Safety Input Device Options](#) on p. 22 and the appropriate standards).**

The commissioning checkout procedure is performed on two occasions:

1. When the Safety Controller is first installed, to ensure proper installation.
2. Whenever any maintenance or modification is performed on the System or on the machine being guarded by the System, to ensure continued proper Safety Controller function (see [Schedule of Required Checkouts](#) on p. 165).

<sup>32</sup> See [Glossary](#) on p. 194 for definitions.

<sup>33</sup> See [Glossary](#) on p. 194 for definitions.

**For the initial part of the commissioning checkout, the Safety Controller and associated safety systems must be checked without power being available to the guarded machine.** Final interface connections to the guarded machine cannot take place until these systems have been checked out.

**Verify that:**

- **The Safety Output leads are isolated**—not shorted together, and not shorted to power or ground
- If used, the external device monitoring (EDM) connections have been connected to +24 V dc via the N.C. monitoring contacts of the device(s) connected to the safety outputs, as described in [External Device Monitoring \(EDM\)](#) on p. 44 and the wiring diagrams
- The proper Safety Controller configuration file for your application has been installed into the Safety Controller
- All connections have been made according to the appropriate sections and comply with NEC and local wiring codes

This procedure allows the Safety Controller and the associated safety systems to be checked out, by themselves, before permanent connections are made to the guarded machine.

## 10.2.2 Initial Setup, Commissioning, and Periodic Checkout Procedures

There are two ways to verify that the Safety Outputs are changing state at the appropriate times in the initial configuration check out phase (open the **Configuration Summary** tab in the Software to view the Start-up test and Power-up configuration settings):

- Monitor the LEDs associated with the inputs and outputs. If the input LED is green, the input is high (or 24 V). If the input LED is red, the input is low (or 0 V). Similarly, if the RO1 or RO2 output contacts are closed, the corresponding LED is green. If the contacts are open, the LED is red.
- Start the **Live Mode** in the Software (the Safety Controller must be powered up and plugged in to the PC via the SC-USB2 cable).

### Start-Up Configuration

Outputs associated with Two-Hand Control, Bypass or Enabling Device functions do not turn on at power-up. After power-up, switch these devices to the Stop state and back to the Run state for their associated outputs to turn On.

**If configured for Normal Power-Up**

If latch function is not used: verify that Safety Outputs turn on after power-up.

If either input devices or outputs use the latch function: verify that Safety Outputs do not turn on after the power-up until the specific manual latch reset operations are performed.

**If configured for Automatic Power-Up**

Verify that all Safety Outputs turn On within approximately 7 seconds (outputs with On-Delay enabled may take longer to turn On).

**If configured for Manual Power-Up**

Verify that all Safety Outputs remain Off after power up.

Wait at least 10 seconds after power-up and perform the Manual Power-Up reset.

Verify that the Safety Outputs turn On (outputs with On-Delay enabled may take longer to turn On).



**CAUTION: Verifying Input and Output Function**

The Qualified Person is responsible to cycle the input devices (Run state and Stop state) to verify that the Safety Outputs turn On and Off to perform the intended safeguarding functions under normal operating conditions and foreseeable fault conditions. Carefully evaluate and test each Safety Controller configuration to make sure that the loss of power to any safeguarding input device, the Safety Controller, or the inverted input signal from a safeguarding input device, do not cause an unintended Safety Output On condition, mute condition, or bypass condition.



**Note:** If an Input or Output indicator is flashing red, see [Troubleshooting](#) on p. 184.

### Safety Input Device Operation (E-stop, Rope Pull, Optical Sensor, Safety Mat, Protective Stop)

1. While the associated Safety Outputs are On, actuate each safety input device, one at a time.
2. Verify that each associated Safety Output turns Off with the proper Off-Delay, where applicable.

3. With the safety device in the Run state:
  - **If a safety input device is configured with a Latch Reset function,**
    1. Verify that the Safety Output remains Off.
    2. Perform a latch reset to turn the outputs On.
    3. Verify that each associated Safety Output turns On.
  - **If no Latch Reset functions are used,** verify that the Safety Output turns On



**Important:** Always test the safeguarding devices according to the recommendations of the device manufacture.

**In the sequence of steps below, if a particular function or device is not part of the application, skip that step and proceed to the next check list item or to the final commissioning step.**

## Two-Hand Control Function without Muting

1. Make sure the Two-Hand Control actuators are in the Stop state.
2. Make sure that all other inputs associated with Two-Hand Control function are in the Run state and activate the Two-Hand Control actuators to turn the associated Safety Output On.
3. Verify that the associated Safety Output remains Off unless both actuators are activated within 0.5 seconds of each other.
4. Verify that Safety Output turns Off and remains Off when any single hand is removed and replaced (while maintaining the other actuator in the Run state).
5. Verify that switching a safety input (non Two-Hand Control actuator) to the Stop state causes the associated Safety Output to turn Off or stay Off.
6. If more than one set of Two-Hand Control actuators are used, the additional actuators need to be activated before the Safety Output turns On. Verify that the Safety Output turns Off and remains Off when any single hand is removed and replaced (while maintaining the other actuators in the Run state).

## Two-Hand Control Function with Muting

1. Follow the verification steps in Two-Hand Control function above.
2. Activate the Two-Hand Control actuators then activate the MP1 sensors.
3. With the MSP1 sensors active, remove your hands from the Two-Hand Control and verify that the Safety Output stays On.
4. Verify that the Safety Output turns Off when either:
  - MSP1 sensors are switched to the stop state
  - Mute time limit expires
5. For multiple Two-Hand Control actuators with at least one set of non-mutable actuators: verify that while in an active mute cycle, removing one or both hands from each non-muted actuators causes the Safety Outputs to turn Off.

## Bidirectional (Two Way) Muting Function (Also valid for Zone Control Mute Functions)

1. With the muted safeguard in the Run state, activate the Mute Enable input (if used) and then activate each mute sensor, in sequential order, within 3 seconds.
2. Generate a stop command from the muted safeguarding device:
  - a) Verify that the associated Safety Outputs remain On.
  - b) If a mute time limit has been configured, verify that the associated Safety Outputs turn Off when the mute timer expires.
  - c) Repeat above steps for each Muting Sensor Pair.
  - d) Verify proper operation with each muted safeguarding device.
  - e) Generate a stop command from any non-muted safeguarding devices one at a time while in the mute cycle and verify that the associated Safety Outputs turn Off.
  - f) Verify the mute process in the opposite direction, repeating the process above, activating the mute sensors in the reverse order.

## Unidirectional (One Way) Muting Function

1. With the mute sensors not activated, muted safeguarding devices in the Run state and Safety Outputs On:
  - a) Activate Muting Sensor Pair 1.
  - b) Change the muted safeguarding device to the Stop state.
  - c) Activate Muting Sensor Pair 2.
  - d) Deactivate Muting Sensor Pair 1.
2. Verify the associated Safety Output remains On throughout the process.
3. Repeat the test in the *wrong direction* (Muting Sensor Pair 2, then the safeguarding device, then Muting Sensor Pair 1).
4. Verify that when the safeguard changes to the Stop state the output turns Off.

## If a mute time limit has been configured

Verify that the associated Safety Outputs turn Off when the mute timer expires.

## Mute Function with Power-Up Operation (not applicable for Two-Hand Control)

1. Turn the Safety Controller power Off.
2. Activate the Mute Enable input if used.
3. Activate an appropriate Muting Sensor Pair for starting a mute cycle.
4. Make sure that all mutable safeguarding devices are in the Run state.
5. Apply power to the Safety Controller.
6. Verify that the Safety Output turns On and that a mute cycle begins.
7. Repeat this test with the mutable safeguard device in the Stop state.
8. Verify that the Safety Output stays Off.

## Mute Function with Mute-Dependent Override

1. Make sure mute sensors are not activated and mute safeguarding devices are in the Run state.
2. Verify that the Safety Outputs are On.
3. Switch the safeguarding device to the Stop state.
4. Verify that the Safety Output turns Off.
5. Activate one of the mute sensors.
6. Verify the optional mute lamp is flashing.
7. Start the mute dependent override by activating the Bypass Switch.
8. Verify that the Safety Output turns On.
9. Verify that the Safety Output turns Off under any of the following conditions:
  - Bypass (Override) Time limit expires
  - Mute sensors are deactivated
  - The Bypass device is deactivated

## Mute Function with Bypass

1. Verify that each safety input, that can be both muted and bypassed, is in the Stop state.
2. Verify that when the Bypass Switch is in the Run state:
  - a) The associated Safety Outputs turn On.
  - b) The associated Safety Outputs turn Off when the bypass timer expires.
3. Change the Bypass Switch to the Run state and verify that the associated Safety Outputs turn On.
4. Switch the associated non-bypassed input devices to their Stop state (one at a time) and verify that associated Safety Outputs turn Off while the Bypass Switch is in the Run state.



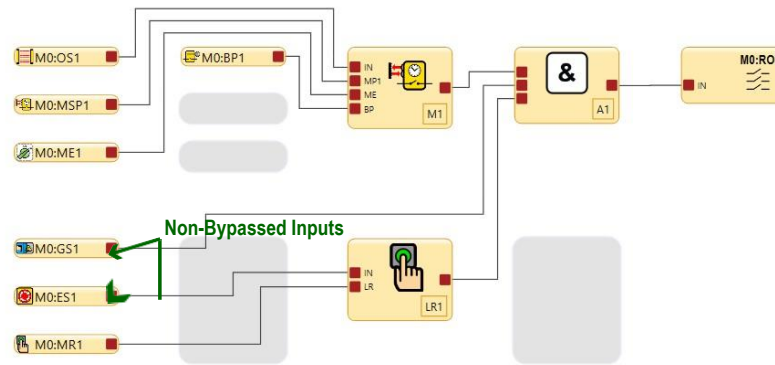

Figure 121: Setup: Inputs without Bypass

## Bypass Function

1. Verify that the associated Safety Outputs are Off when the safety inputs to be bypassed are in the Stop state.
2. Verify that when the Bypass Switch is in the Run state:
  - a) The associated Safety Outputs turn On.
  - b) The associated Safety Outputs turn Off when the bypass timer expires.
3. Change the Bypass Switch to the Run state and verify that the associated Safety Outputs turn On.
4. One at a time, switch the non-bypassed input devices to the Stop state and verify that the associated Safety Outputs turn Off while the Bypass Switch is in the Run state.

## Safety Output Off-Delay Function

1. With any one of the controlling inputs in the Stop state and the delayed Safety Output in an Off delay state, verify that the Safety Output turns Off after the time delay is over.
2. With any one of the controlling inputs in the Stop state and the Off Delay timer is active, switch the input to the Run state and verify that the Safety Output is On and remains On.

## Safety Output Off-Delay Function—Cancel Delay Input

With the associated inputs in the Stop state and the delayed Safety Output in an Off delay state, activate the Cancel Delay input and verify that the Safety Output turns Off immediately.

## Safety Output Off-Delay Function—Controlling Inputs

1. With any one of the controlling inputs in the Stop state and the delayed Safety Output is in an Off delay state, switch the input to the Run state.
2. Verify that the Safety Output is On and remains On.

## Safety Output Off-Delay Function and Latch Reset

1. Make sure the associated input devices are in the Run state so that the delayed Safety Output is On.
2. Start the off delay time by switching an input device to the Stop state.
3. Switch the input device to the Run state again during the Off-Delay time and push the Reset button.
4. Verify that the delayed output turns Off at the end of the delay and remains Off (a latch reset signal during the delay time is ignored).

## Enabling Device Function without Secondary Jog Output

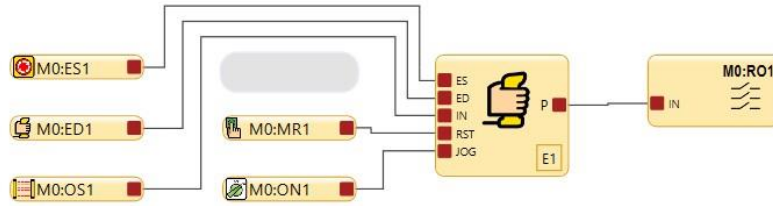

Figure 122: Setup: Enabling Device Function without Secondary Jog Output

1. With the associated inputs in the Run state and the Enabling Device in the Stop state, verify that the Safety Output is On.
2. With the Enabling Device still in the Run state and the associated Safety Output On, verify that the Safety Output turns Off when the Enabling Device timer expires.
3. Return the Enabling Device to the Stop state and then back to the Run state, and verify that the Safety Outputs turns On.
4. Switch the Enabling Device to the Stop state, and verify that the associated Safety Outputs turn Off.
5. Switch each E-stop and Rope Pull device associated with the Enabling Device function to the Stop state, and verify, one at a time, that the associated Safety Outputs are On and in the Enable mode.
6. With the Enabling Device in the Stop state, perform a reset.
7. Verify that control authority is now based on associated input devices of the Enabling device function:
  - a) If one or more input devices are in the Stop state, verify that the output is Off.
  - b) If all of the input devices are in the Run state, verify that the output is On.

## Enabling Device Function—With Jog feature on the Secondary Output

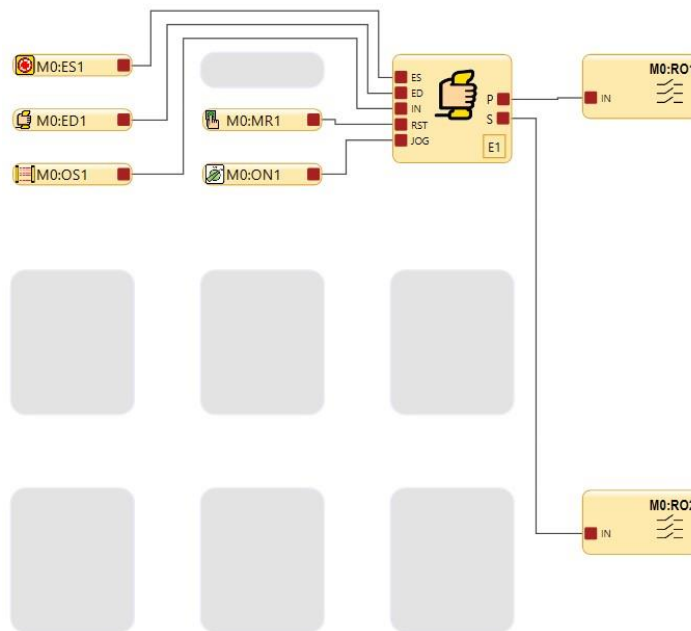

Figure 123: Setup: Enabling Device Function—With Jog feature on the Secondary Output

1. With the Enabling Device and the Jog button in the Run state in control of the primary Safety Output, verify that the output turns Off when either the Enabling Device or the Jog button is switched to the Stop state.
2. With the Enabling Device in control of the primary Safety Output and the Jog button in control of the secondary output verify that the primary Output turns:
  - a) On when the Enabling Device is in the Run state.
  - b) Off when the Enabling Device is in the Stop state and the Jog button is in the Run state.
3. Verify that the output turns On only when the Enabling Device is in the Run state while the Jog button is in the Run state.

4. Verify that the secondary Output turns:
  - a) On when the Enabling Device and the jog button are in the Run state.
  - b) Off when the either the Enabling Device or the job button are in the Stop state.

# 11 Status and Operating Information

Operate the SCR P Safety Controller using the Software to monitor ongoing status.

## 11.1 SCR P LED Status

---

Use the following table to determine the status of the Safety Controller.

The LEDs are always on unless the Safety Controller is off.

LED	Status	Meaning
All	Off	Initialization Mode
	<b>Sequence:</b> Green On for 0.5 s Red On for 0.5 s Off for 0.5 s minimum	Power applied
Power/Fault (1)	Green: Solid	24 V dc connected
	Green: Flashing	Configuration or Manual Power-Up mode Configuration via SCR P-FPS: Cycle Power
	Red: Flashing	Non-operating Lockout condition
USB (1)	Green: Solid	USB cable connected or SCR P-FPS plugged in
	Green: Flashing	Factory default Safety Controller: no USB cable connected or SCR P-FPS plugged in
	Green: Fast flashing for 3 s, then solid	Configured (locked or unlocked) SCR P-FPS plugged into a factory default Safety Controller; the configuration, network settings, and passwords transfer from the SCR P-FPS to the Safety Controller
	Green: Flashing for 3 s, then solid	Configured and unlocked SCR P-FPS plugged into a configured Safety Controller with a matching configuration and matching passwords
		 <b>Note:</b> If there are mismatched network settings, the network settings transfer from the Safety Controller to an unlocked SCR P-FPS. Network settings do not transfer to a locked SCR P-FPS.
	Green: Flashing for 3 s, then Red: Flashing	Configured and locked SCR P-FPS plugged into a configured Safety Controller with a matching configuration and matching passwords, but mismatched network settings
	Red: Solid	Configured Safety Controller: no USB cable connected or SCR P-FPS plugged in
Inputs (10)	Red: Flashing	Configured (locked or unlocked) SCR P-FPS plugged into a configured Safety Controller with a mismatched configuration, a mismatched password, or a blank SCR P-FPS plugged into any Safety Controller
	Green: Solid	24 V dc and no fault
	Green: Solid	Input configured as status output and active
	Red: Solid	0 V dc and no fault
	Red: Solid	Input configured as status output and inactive
RO1, RO2 (2)	Red: Flashing	All terminals of a faulted input (includes shared terminals)
	Green: Solid	On (contacts closed)
	Red: Solid	Off (contacts open) or not configured
	Red: Flashing	Safety Output fault detected or EDM fault detected or AVM fault detected

Ethernet Diagnostic LEDs		
Amber LED	Green LED	Description
On	Varies with traffic	Link established/normal operation
Off	Off	Hardware failure

Amber LED and Green LED Flash in Unison	Description
5 flashes followed by several rapid flashes	Normal power up
1 flash every 3 seconds	Contact BERNSTEIN
2 flash repeating sequence	In the past 60 seconds, a cable was unplugged while active
3 flash repeating sequence	A cable is unplugged
4 flash repeating sequence	Network not enabled in the configuration

Amber LED and Green LED Flash in Unison	Description
5+ flash repeating sequence	Contact BERNSTEIN

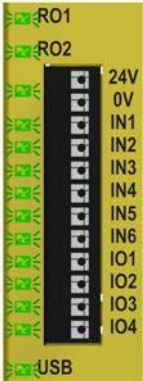
PROFINET Flash Command	Meaning
<p>All LEDs flash for 4 seconds</p> 	<p>The flashing LEDs indicate that the SCR P is connected. It is the result of the "Flash LED" command from the PROFINET network.</p>

## 11.2 Live Mode Information: Software

To display real-time Run mode information on a PC, the Safety Controller must be connected to the computer via the USB cable. Click  **Live Mode** to access the **Live Mode** tab. This feature continually updates and displays data, including Run, Stop, and Fault states of all inputs and outputs, as well as the Fault Codes table. The **Equipment** tab and the **Functional View** tab also provide device-specific visual representation of the data. See [Live Mode](#) on p. 101 for more information.

## 11.3 Lockout Conditions

Input lockout conditions are generally resolved by repairing the fault and cycling the input Off and then back On.

Output lockout conditions (including EDM and AVM faults) are resolved by repairing the fault and then cycling the Reset Input connected to the FR node on the Safety Output.

System faults, such as low supply voltage, overtemperature, or voltage detected on unassigned inputs, may be cleared by cycling the System Reset input (any Reset Input assigned to be the System Reset). Only one reset button, either physical or virtual, can be configured to perform this operation.

A system reset is used to clear lockout conditions not related to safety inputs or outputs. A lockout condition is a response where the Safety Controller turns Off all affected Safety Outputs when a safety-critical fault is detected. Recovery from this condition requires all faults to be remedied and a system reset to be performed. A lockout will recur after a system reset unless the fault that caused the lockout has been corrected.

A system reset is necessary under the following conditions:

- Recovering from a system lockout condition
- Starting the Safety Controller after a new configuration has been downloaded

For internal faults, the System Reset likely will not work. The power will have to be cycled in an attempt to run again.

<sup>34</sup> **System Status** is the first screen that displays when the Safety Controller turns On after a reset. Click **ESC** to view the **System Menu**.

**WARNING: Non-Monitored Resets**

If a non-monitored reset (either latch or system reset) is configured and if all other conditions for a reset are in place, a short from the Reset terminal to +24 V will turn On the safety output(s) immediately.

**WARNING: Check Before Reset**

When performing the system reset operation, it is the user's responsibility to make sure that all potential hazards are clear and free of people and unwanted materials (such as tools) that could be exposed to the hazard. **Failure to follow these instructions could result in serious injury or death.**

## 11.4 Recovering from a Lockout

---

To recover from a lockout condition:

- Follow the recommendation in the fault display (LCD models)
- Follow the recommended steps and checks listed in the [SCR P Fault Code Table](#) on p. 188
- Perform a system reset
- Cycle the power and perform a system reset, if needed

If these steps do not remedy the lockout condition, contact BERNSTEIN (see [Repairs and Warranty Service](#) on p. 191).

## 11.5 SCR P Using Automatic Terminal Optimization

---

Follow these steps for an example configuration that uses the Automatic Terminal Optimization (ATO) feature.





**Note:** This procedure is an example only.

1. Click **New Project** to start a new project.
2. Select SCR P **Series**.
3. Define the project settings and click **OK**.



**Note:** Make sure that **Disable Automatic Terminal Optimization Feature** checkbox is clear.

The project is created.

4. On the **Equipment** tab, click  below the Safety Controller. The **Add Equipment** window opens.
5. Add an Emergency Stop button and click **OK** to accept the default settings.
6. Click .
7. Add an Optical Sensor and click **OK** to accept the default settings.
8. Click .
9. Add a Gate Switch and click **OK** to accept the default settings.
10. Go to the **Wiring Diagram** tab and notice the terminals that are used.

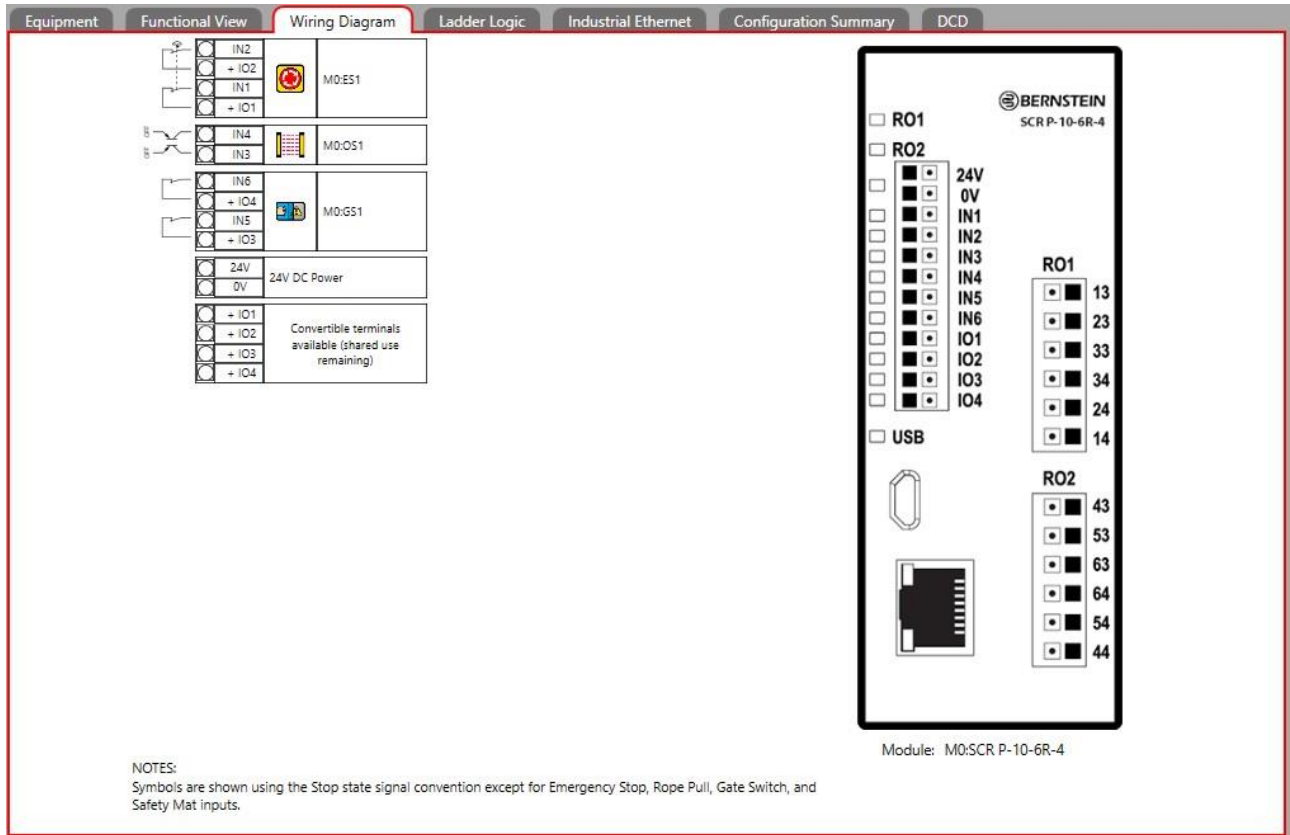



Figure 124: **Wiring Diagram** tab with an E-stop button, optical sensor, and gate switch

11. Go to the **Equipment** tab and click .
12. Add a second Gate Switch and click **OK** to accept the default settings.
13. Go to the **Wiring Diagram** tab, and notice that external terminal blocks (ETB) have been added to accommodate the second Gate Switch.



**Note:** External terminal blocks are user-provided.

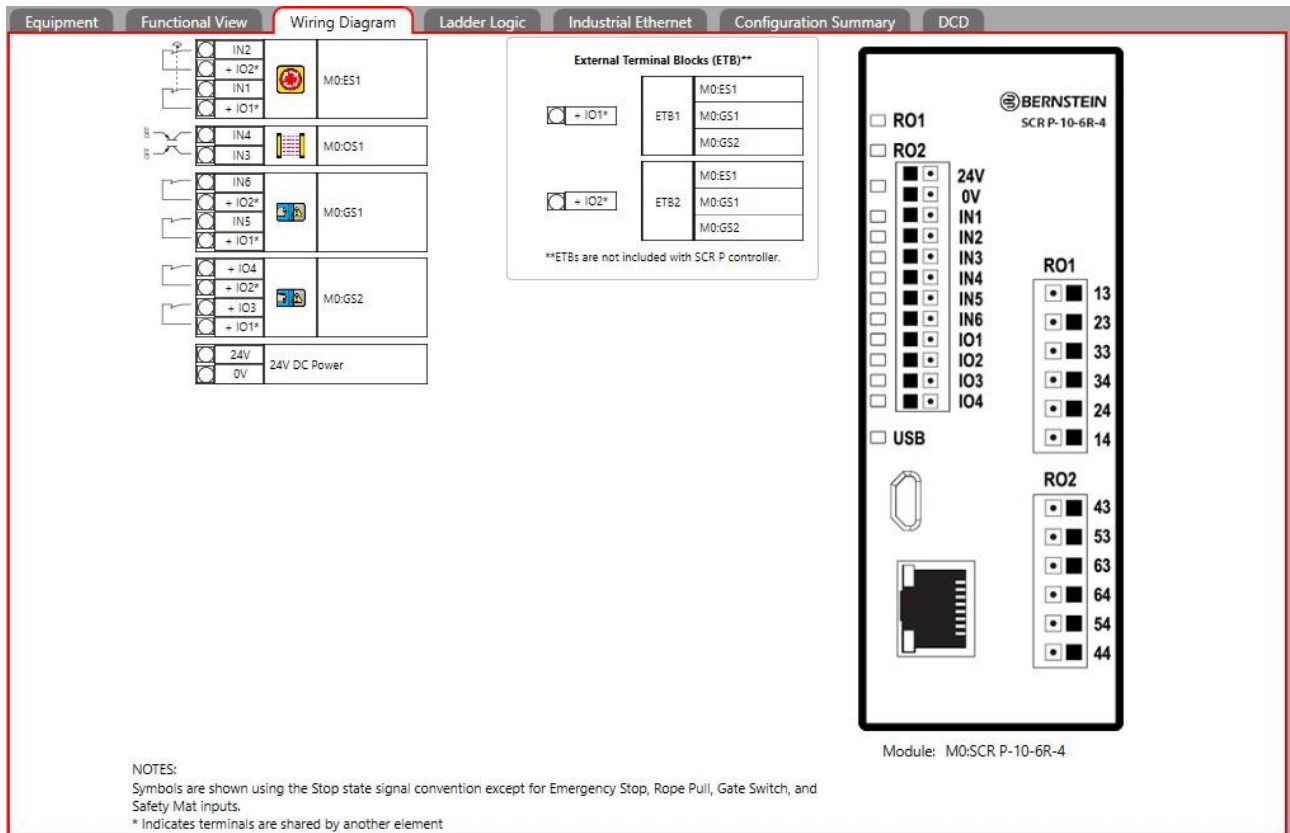

 Figure 125: *Wiring Diagram* Tab with Three E-stop Buttons and ETBs

## 11.6 SCR P Example Configuration without Automatic Terminal Optimization

Follow these steps for an example configuration where the Automatic Terminal Optimization (ATO) feature is disabled.



**Note:** This procedure is an example only.

1. Click **New Project** to start a new project.
2. Select **SCR P Series**.
3. Define the project settings, select the **Disable Automatic Terminal Optimization Feature** checkbox, and click **OK**.



**Note:** Make sure that **Disable Automatic Terminal Optimization Feature** checkbox is selected.

Figure 126: *Disable Automatic Terminal Optimization Feature Selected*

The project is created.

4. On the **Equipment** tab, click below the Safety Controller. The **Add Equipment** window opens.
5. Add an Emergency Stop button and click **OK** to accept the default settings.
6. Click .
7. Add an Optical Sensor and click **OK** to accept the default settings.
8. Click .
9. Add a Gate Switch and click **OK** to accept the default settings.
10. Go to the **Wiring Diagram** tab and notice the terminals that are used.

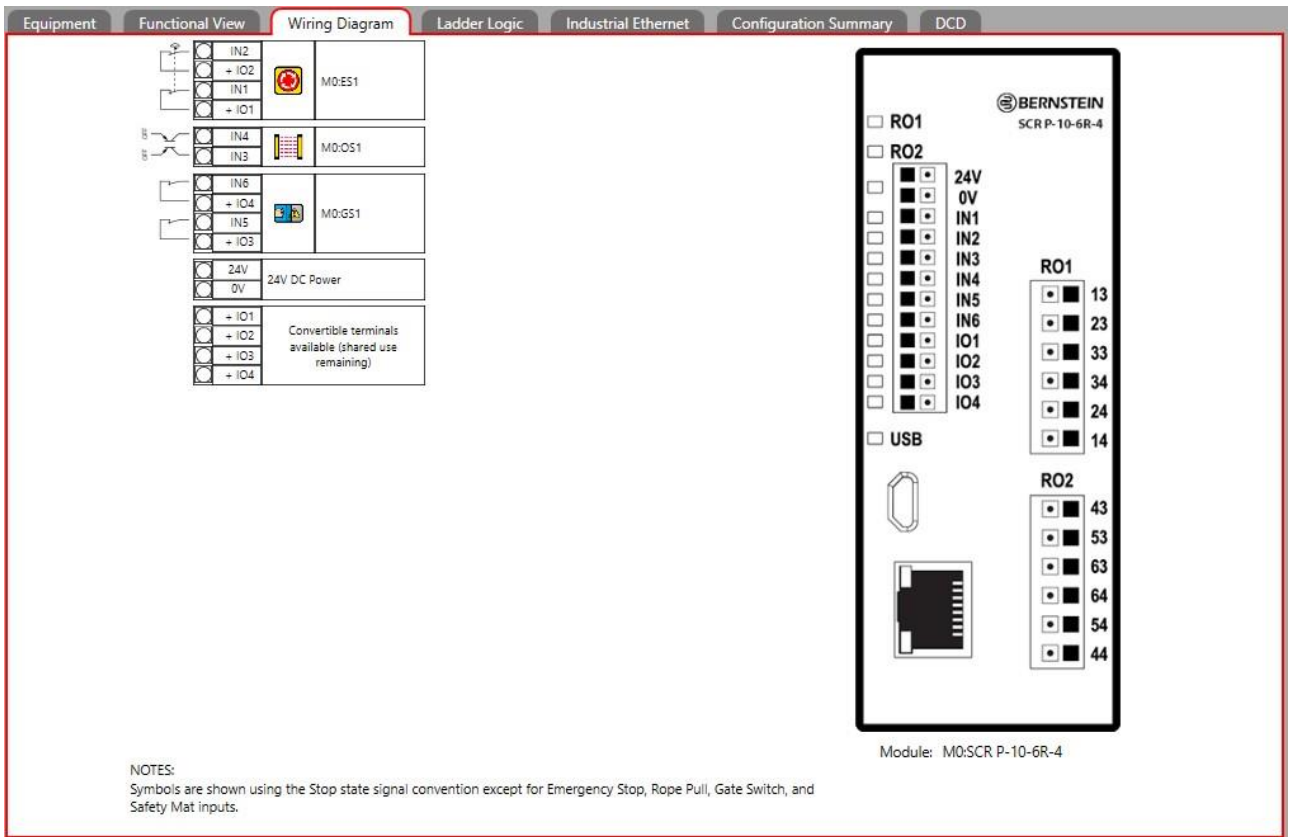

Figure 127: **Wiring Diagram** tab with an E-stop button, optical sensor, and gate switch

11. Go to the **Equipment** tab and try to add another Gate Switch.  
No other equipment can be added ( + does not appear) because the ATO feature is disabled and there are not enough terminals to support more equipment.
12. Go to the **Functional View** tab and try to add another Gate Switch.  
No other equipment can be added here either because the ATO feature is disabled.
13. Click **Cancel**.
14. On the **Functional View** tab, click on the Gate Switch and then click **Edit** to change the properties.
  - a) Change the IO3 and IO4 terminals to IO1 and IO2 respectively.

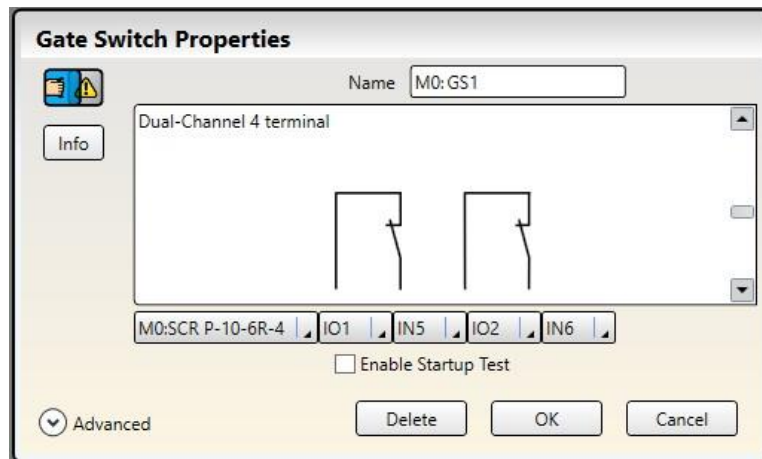

Figure 128: Gate Switch Properties

- b) Click **OK**.
15. Go to the **Wiring Diagram** tab and notice that external terminal blocks (ETB) have been added to accommodate the change in terminal assignments of the Gate Switch.



**Note:** External terminal blocks are user-provided.

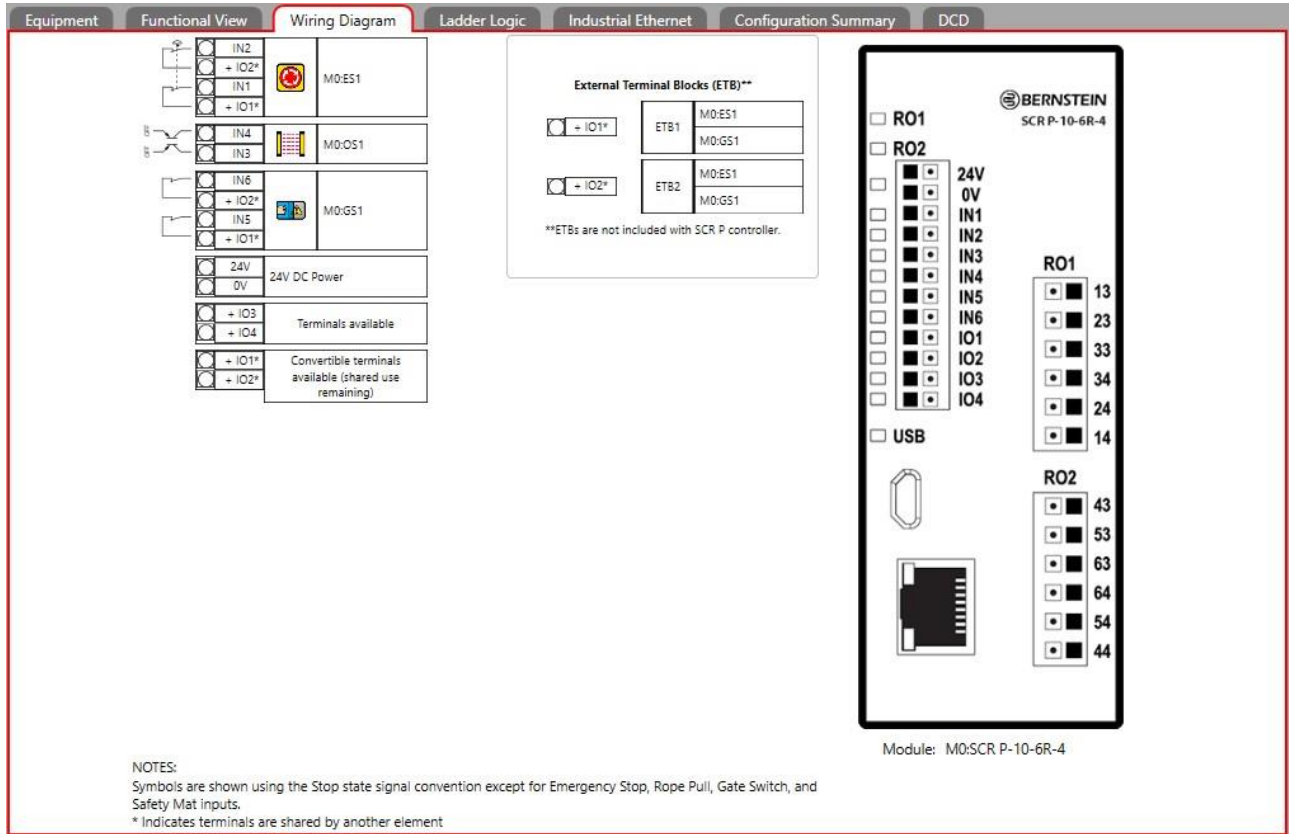

Figure 129: *Wiring Diagram* tab with an E-stop button, optical sensor, gate switch, and ETBs

16. Go to the **Functional View** tab to try to add another Gate Switch.  
Another Gate Switch can now be added because terminal optimization has been done manually.
17. Add a second Gate Switch and click **OK** to accept the default settings.
18. Go to the **Wiring Diagram** tab and notice the second Gate Switch has been added and no additional ETB has been added.

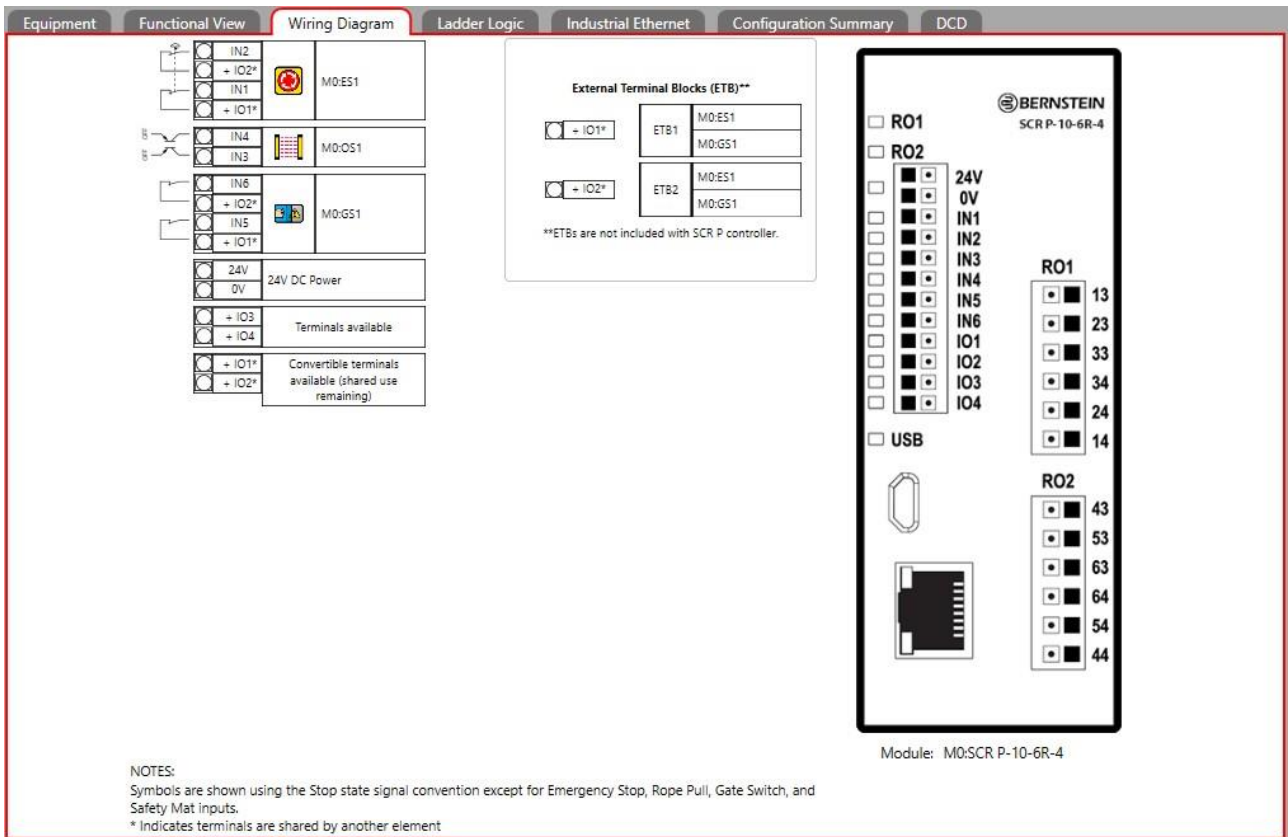

Figure 130: **Wiring Diagram** tab with an E-stop button, optical sensor, gate switches, and ETBs

## 11.7 SCR P Using the SCR P-FPS

Use an SCR P-FPS to:

- Quickly configure multiple SCR P Safety Controllers with the same configuration
- Replace one SCR P Safety Controller with another using the SCR P-FPS from the old Safety Controller



**Note:** The Bernstein AG programming tool (SCR P-PA) and Software are required to write a confirmed configuration to an SCR P-FPS. This limits access to authorized personnel.

1. Create the desired configuration using the Software.
2. Review and confirm the configuration by loading it onto an SCR P.  
After review and approval, the configuration can be saved and used by the Safety Controller.
3. Write the confirmed configuration to the SCR P-FPS using the programming tool.



**Note:** Only confirmed configurations can be stored on the SCR P-FPS.

4. Use a label to indicate the configuration that is stored on the SCR P-FPS.
5. Install and/or connect power to the desired SCR P (factory default Safety Controller or configured Safety Controller).
  - If the SCR P is a factory default Safety Controller, the power/fault LED is on green and the USB LED flashes green to indicate that the Safety Controller is waiting for a configuration.
  - If the SCR P is a configured Safety Controller, the power/fault LED is on green and the USB LED is on red.
6. Insert the SCR P-FPS into the micro USB port on the SCR P.

### Factory Default Safety Controller

- The USB LED fast flashes for 3 seconds, then stays on, and the configuration, network settings, and passwords automatically download to the Safety Controller. Then, the power/fault LED flashes green to indicate that the Safety Controller is waiting for a power cycle.

### Configured Safety Controller

- If the configuration and passwords on the Safety Controller and the SCR P-FPS match, the USB LED flashes green for 3 seconds and then stays on. Also, if the network settings do not match, the network settings of the Safety Controller transfer to the SCR P-FPS after 3 seconds, as long as the SCR P-FPS is not locked. If the SCR P-FPS is locked, the controller enters a lockout state.

- If the configuration or the passwords on the Safety Controller and the SCR P-FPS do not match, the USB LED flashes red. If the SCR P-FPS is not disconnected from the Safety Controller within 3 seconds, the power/fault and USB LEDs flash red and the Safety Controller enters a lockout state due to the mismatch.
7. Cycle the power.  
The power/fault LED is green, the USB LED is green (if the SCR P-FPS is still plugged in) or red (no SCR P-FPS or USB cable connected), and the Input and Output LEDs show actual input status.

The Safety Controller is ready for commissioning. See [Commissioning Checkout Procedure](#) on p. 165.

## 11.8 Reset the Safety Controller to Factory Defaults

The Safety Controller must be powered up and connected to the PC via the USB cable.

1. Click  .
2. Click **Reset to Factory Default**.  
A caution displays reminding you that all settings will change to factory defaults.
3. Click **Continue**.  
The **Enter Password** screen opens.
4. Enter the User1 password and click **OK**.  
The Safety Controller is updated to the factory default settings and a confirmation window displays.
5. Click **OK**.
6. Cycle the power.  
The reset to factory default process is complete.

## 11.9 Factory Defaults

The following table lists some of the factory default settings for both the Safety Controller and the Software.

Setting	Factory Default	Applicable Product
AVM Function	50 ms	SCR P
Closed-to-Open Debounce Time	6 ms	SCR P
EDM	No monitoring	SCR P
Function Block: Bypass Block Default Nodes	IN, BP	SCR P
Function Block: Bypass Time Limit	1 s	SCR P
Function Block: Delay Block—Default Nodes	IN	SCR P
Function Block: Delay Block—Output Delay	100 ms	SCR P
Function Block: Enabling Device Block—Default Nodes	ED, IN, RST	SCR P
Function Block: Enabling Device Block—Time Limit	1 s	SCR P
Function Block: Latch Reset Block—Default Nodes	IN, LR	SCR P
Function Block: Muting Block—Default Nodes	IN, MP1	SCR P
Function Block: Muting Block—Time Limit	30 s	SCR P
Function Block: Two-Hand Control Block—Default Nodes	TC	SCR P
Industrial Ethernet: String (EtherNet/IP and PCCC Protocol)	32 bit	SCR P
Network Settings: Gateway Address	0.0.0.0	SCR P
Network Settings: IP Address	192.168.0.128	SCR P
Network Settings: Link Speed and Duplex Mode	Auto Negotiate	SCR P

<b>Setting</b>	<b>Factory Default</b>	<b>Applicable Product</b>
Network Settings: Subnet Mask	255.255.255.0	SCR P
Network Settings: TCP Port	502	SCR P
Open-to-Closed Debounce Time	50 ms	SCR P
Power up mode	Normal	SCR P
Safety Outputs	Automatic reset (trip mode)	SCR P
Safety Outputs: Power-up Mode	Normal	SCR P
Safety Outputs: Split (Safety Outputs)	Function in pairs	SCR P
Simulation Mode: Simulation Speed	1	SCR P
Automatic Terminal Optimization	Enabled	SCR P
Status Output Signal Conventions	Active = PNP On	SCR P

# 12 Troubleshooting

The Safety Controller is designed and tested to be highly resistant to a wide variety of electrical noise sources that are found in industrial settings. However, intense electrical noise sources that produce EMI or RFI beyond these limits may cause a random trip or lockout condition. If random trips or lockouts occur, check that:

- The supply voltage is within 24 V dc  $\pm$  20%
- The Safety Controller's plug-on terminal blocks are fully inserted
- Wire connections to each individual terminal are secure
- No high-voltage or high-frequency noise sources or any high-voltage power lines are routed near the Safety Controller or alongside wires that are connected to the Safety Controller
- Proper transient suppression is applied across the output loads
- The temperature surrounding the Safety Controller is within the rated ambient temperature (see [Specifications and Requirements](#) on p. 12)

## 12.1 Software: Troubleshooting

### Live Mode button is unavailable (grayed out)

1. Make sure the USB cable is plugged into both the computer and the Safety Controller.



**Note:** Make sure you use USB cables that the cable includes a communication line. Many cell phone charging cables do not have a communication line.

2. Verify that the Safety controller is installed properly—see [Verifying Driver Installation](#) on p. 186.
3. Exit the Software.
4. Unplug the Safety controller and plug it back in.
5. Start the Software.

### Unable to read from the Safety Controller or send the configuration to the Safety Controller (buttons grayed out)

1. Make sure **Live Mode** is disabled
2. Make sure the USB cable is plugged into both the computer and the Safety Controller



**Note:** Make sure you use USB cables that the cable includes a communication line. Many cell phone charging cables do not have a communication line.

3. Verify that the Safety Controller is installed properly—see [Verifying Driver Installation](#) on p. 186.
4. Exit the Software.
5. Unplug the Safety Controller and plug it back in.
6. Start the Software.

### Unable to move a block to a different location

Not all blocks can be moved. Some blocks can be moved only within certain areas.

- **Safety Outputs** are placed statically and cannot be moved. **Referenced Safety Outputs** can be moved anywhere within the left and middle areas.
- **Safety** and **Non-Safety Inputs** can be moved anywhere within the left and middle areas.
- **Function** and **Logic blocks** can be moved anywhere within the middle area.

### SC-XM2/3 button is unavailable (grayed out)

1. Make sure all connections are secure—SCR P-PA to the USB port of the computer and to the SCR P-FPS drive.
2. Verify that the SCR P-PA Programming Tool is installed properly—see [Verifying Driver Installation](#) on p. 186.
3. Exit the Software.
4. Disconnect and re-connect all connections— SCR P-PA to the USB port of the computer and to the SCR P-FPS drive.
5. Start the Software.



 **Note:** Contact a BERNSTEIN Applications Engineer if you require further assistance.

## 12.2 Software: Error Codes

The following table lists error codes that are encountered when attempting to make an invalid connection between blocks on the **Functional View** tab.

Software Code	Error
A.1	This connection creates a loop.
A.2	A connection from this block already exists.
A.3	Connecting a block to itself is not allowed.
B.2	This Bypass Block is connected to a Two-Hand Control Block. You can connect only a Two-Hand Control input to the <b>IN</b> node.
B.3	This Bypass Block is already connected to another block.
B.4	This Bypass Block is connected to the <b>TC</b> node of a Two-Hand Control Block and cannot be connected to any other blocks.
B.5	Cannot connect Two-Hand Control Input to the <b>IN</b> node of this Bypass Block because it has the "Output turns Off when both inputs (IN and BP) are On" option disabled.
B.6	The <b>IN</b> node of a Bypass Block cannot be connected to Emergency Stop and Rope Pull inputs.
B.7	The <b>IN</b> node of a Bypass Block cannot be connected to Emergency Stop and Rope Pull inputs via other blocks.
C.1	Only a Cancel Off Delay input can be connected to the <b>CD</b> node.
C.2	A Cancel Off Delay input can be connected only to the <b>CD</b> node of a Safety Output.
D.1	This External Device Monitoring input is configured for a Dual-Channel 2 Terminal circuit and can be connected only to the <b>EDM</b> node of a Safety Output.
E1	The Enabling Device Block output nodes ( <b>P</b> or <b>S</b> ) can be connected only to the <b>IN</b> node of a Safety Output.
E.2	The <b>IN</b> node of an Enabling Device Block cannot be connected to Emergency Stop and Rope Pull inputs.
E.3	The <b>ED</b> node of an Enabling Device Block can be connected only to an Enabling Device input.
E.4	The <b>ED</b> node of an Enabling Device Block cannot be connected to Emergency Stop and Rope Pull inputs via other blocks.
E.5	An Enabling Device Block that has a Two-Hand Control input connected to the <b>IN</b> node cannot be connected to a Safety Output that has <i>Safety Output Delay</i> set to "Off Delay".
E.6	The secondary output node <b>S</b> of an Enabling Device Block can be connected only to the <b>IN</b> node of a Safety Output.
F.1	Emergency Stop and Rope Pull inputs cannot be muted.
F.2	Emergency Stop and Rope Pull inputs cannot be connected to a Latch Reset Block that is connected to a Muting Block.
F.3	A Latch Reset Block that is connected to an Emergency Stop or a Rope Pull input cannot be connected to a Muting Block.
G.1	Only a Manual Reset input can be connected to the <b>FR</b> node of a Safety Output.
G.2	Only a Manual Reset input can be connected to the <b>LR</b> node of a Latch Reset Block or Safety Output.
G.3	Only a Manual Reset input can be connected to the <b>RST</b> node of an Enabling Device Block.
G.4	A Manual Reset input can be connected only to <b>LR</b> and <b>FR</b> nodes of a Safety Output, an <b>LR</b> node of a Latch Reset Block, an <b>RST</b> node of an Enabling Device Block, and <b>SET</b> and <b>RST</b> nodes of the Flip-Flop Blocks.
H.1	A latch reset block already connected to a function block cannot connect to a Mute block.
H.2	A latch reset block already connected to a Mute block cannot connect to another function block.
I.1	Only Muting Sensor Pair, Optical Sensor, Gate Switch, Safety Mat, or Protective Stop inputs can be connected to the <b>MP1</b> and <b>MP2</b> nodes of a Muting Block or to the <b>MP1</b> node of a Two-Hand Control Block.
I.2	The <b>MP1</b> and <b>MP2</b> nodes of a Muting Block and the <b>MP1</b> node of a Two-Hand Control Block can be connected to inputs that are using only Dual-Channel circuits.
I.3	A Muting Sensor Pair input can be connected only to <b>MP1</b> and <b>MP2</b> nodes of a Muting Block or the <b>MP1</b> node of a Two-Hand Control Block.

Software Code	Error
J.1	<b>SCR P</b> A Two-Hand Control Block can be connected only to an Enabling Device Block ( <b>IN</b> node), a Safety Output ( <b>IN</b> node), or Logic Blocks (excluding Flip-Flop Blocks).
J.3	Only Two-Hand Control inputs or Bypass Blocks with Two-Hand Control inputs connected to them can be connected to the <b>TC</b> node of a Two-Hand Control Block.
K.1	<b>SCR P</b> A Two-Hand Control input can be connected only to a Two-Hand Control Block ( <b>TC</b> node), Bypass Block ( <b>IN</b> node), Logic Blocks (excluding Flip-Flop Blocks), or an output without an off-delay.
K.2	<b>SCR P:</b> A Safety Output that has <i>Safety Output Delay</i> set to "Off Delay" cannot be directly connected to a Two-Hand Control Block.
K.3	A Safety Output that has <i>Safety Output Delay</i> set to "Off Delay" cannot be connected to a Two-Hand Control Block via an Enabling Device Block.
L.1	This Safety Output is disabled because a Status Output is using its terminals.
L.2	The <b>IN</b> node of a Safety Output cannot be connected to External Device Monitoring, Adjustable Valve Monitor, Mute Sensor Pair, Bypass Switch, Manual Reset, Mute Enable, or Cancel Off Delay inputs.
L.3	A Safety Output block that has <i>LR (Latch Reset)</i> function enabled cannot be connected to Two-Hand Control Blocks or Enabling Device Blocks.
L.4	A Safety Output block that has <i>Power up Mode</i> set to "Manual Reset" cannot be connected to Two-Hand Control Blocks or Enabling Device Blocks.

## 12.3 Verifying Driver Installation

### Windows 7, 8 and 10

1. Click **Start**.
2. Type "Device Manager" in the *Search for programs and files* field at the bottom and click **Device Manager** when Windows locates it.
3. Expand the **Ports (COM & LPT)** dropdown menu.
4. Find **Safety Controller** followed by a COM port number (for example, COM3). It must not have an exclamation mark, a red x, or a down arrow on the entry. If you do not have any of these indicators, your device is properly installed. If any of the indicators appear, follow the instructions after this table to resolve these issues.

### SCR P-PA Drivers

1. Expand the **Universal Serial Bus controller** dropdown menu.
2. Find **SC Programmer A** and **SC Programmer B**. Either one of the entries must not have an exclamation mark, a red x, or a down arrow on the entry. If you do not have any of these indicators, your device is properly installed. If any of the indicators appear, follow the instructions after this table to resolve these issues.

## Windows 7, 8 and 10

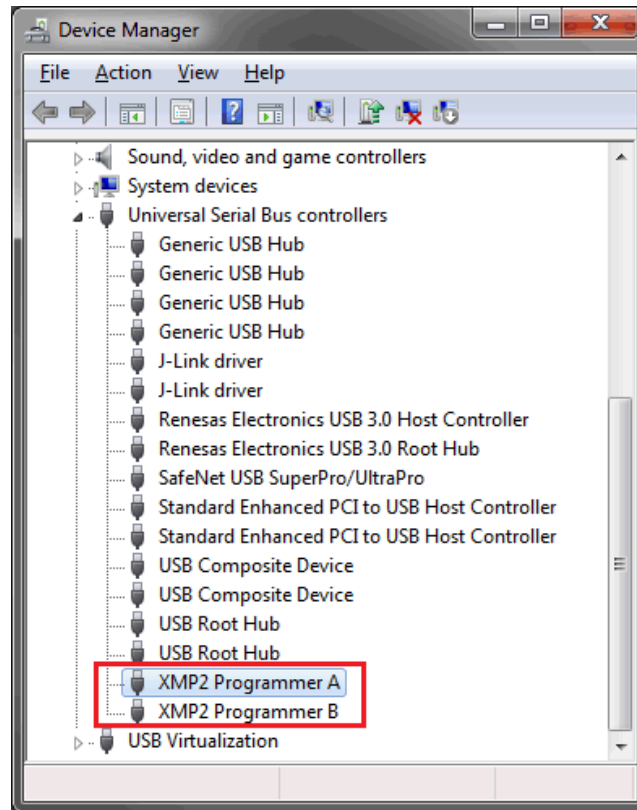

Figure 131: SCR P-PA Drivers installed correctly

**To resolve an exclamation mark, a red x, or a down arrow indicator:**

1. Make sure your device is enabled:
  - a. Right-click on the entry that has the indicator.
  - b. If you see **Disable**, the device is enabled; if you see **Enable**, the device is disabled.
    - If the device is enabled, continue with troubleshooting steps.
    - If the device is disabled, click **Enable**. If this does not remove the indicator, continue to the next step.
2. Unplug the USB cable either from the Safety Controller or from the computer, wait a few seconds and plug it back in. If this does not remove the indicator, continue to the next step.
3. Try plugging in the Safety Controller to a different USB port. If this does not remove the indicator, continue to the next step.
4. Reboot your computer. If this does not remove the indicator, continue to the next step.
5. Uninstall and re-install the software from **Add/Remove Programs** or **Programs and Features** located in the **Control Panel**. If this does not remove the indicator, continue to the next step.
6. Contact a BERNSTEIN Applications Engineer.

**To resolve the Safety Controller listed in Device Manager as 'Generic USB Device', follow these steps.**

1. Right click on the Generic USB Device port that is the BERNSTEIN Safety Controller.
2. Click **Update Driver**.
3. Select **Browse my Computer for Driver Software**.
4. Click the **Browse** box to the right of the **Search this Location** box. A new window opens.
5. Select **Local Disk (C:) > Program Files (x86) > BERNSTEIN AG > BERNSTEIN Safety Controller > Driver**.
6. Click **OK**, closes this window.
7. In the update driver box, click **Next**. The driver should now be updated.

You might have to close the BERNSTEIN Safety Controller Software and open it again. The USB ports should now link BERNSTEIN Safety Controllers to the Software.

## 12.4 Finding and Fixing Faults

Depending on the configuration, the Safety Controller is able to detect a number of input, output, and system faults, including:

- A stuck contact
- An open contact
- A short between channels
- A short to ground
- A short to a voltage source
- A short to another input
- A loose or open connection
- An exceeded operational time limit
- A power drop
- An overtemperature condition

When a fault is detected, a message describing the fault displays in the **Fault Diagnostics** menu (LCD models). For models not equipped with an LCD, use the **Live Mode** tab in the Software on a PC connected to Safety Controller with the SC-USB2 cable. Fault diagnostics are also available over the network. An additional message may also be displayed to help remedy the fault.



**Note:** The fault log is cleared when power to the Safety Controller is cycled.

### 12.4.1 SCR P Fault Code Table

The following table lists the Safety Controller Fault Code, the message that displays, any additional messages, as well as the steps to resolve the fault.

The Error Code and the Advanced Error Code, taken together, form the Safety Controller Fault Code. The format for the Fault Code is `Error Code 'dot' Advanced Error Code`. For example, a Safety Controller Fault Code of 2.1 is represented by an Error Code of 2 and an Advanced Error Code of 1. The Error Message Index value is the Error Code and the Advanced Error Code together and includes a leading zero with the Advanced Error Code, if necessary. For example, a Safety Controller Fault Code of 2.1 is represented by an Error Message Index of 201. The Error Message Index value is a convenient way to get the complete Fault Code while only reading a single 16-bit register.

Fault Code	Fault Code Description	Steps to resolve
1.1 – 1.2	Output Fault	Replace the Safety Controller
1.3 – 1.8	Internal Fault	Internal failure—Contact BERNSTEIN AG (see <a href="#">Repairs and Warranty Service</a> on p. 191)
1.9	Output Fault	Replace the Safety Controller
1.10	Output Fault	Sequence timing error: <ul style="list-style-type: none"> <li>• Perform a System Reset to clear the fault</li> </ul>
2.1	Concurrency Fault	On a dual-channel input, or a complementary input, with both inputs in the Run state, one input went to the Stop state then back to Run. On a dual-complementary input, with both pairs of inputs in the Run state, one pair of inputs went to the Stop state then back to Run. <ul style="list-style-type: none"> <li>• Check the wiring</li> <li>• Check the input signals</li> <li>• Consider adjusting the debounce times</li> <li>• Cycle input</li> </ul>

Fault Code	Fault Code Description	Steps to resolve
2.2	Simultaneity Fault	<p>On a dual-channel input, or a complementary input, one input went into the Run state but the other input did not follow the change within 3 seconds.</p> <p>On a dual-complementary input, one pair of inputs went into the Run state but the other pair of inputs did not follow the change within 3 seconds.</p> <ul style="list-style-type: none"> <li>• Check the wiring</li> <li>• Check the input signal timing</li> <li>• Cycle input</li> </ul>
2.3 or 2.5	Concurrency Fault	<p>On a dual-complementary input, with both inputs of one complementary pair in the Run state, one input of this complementary pair changed to Stop then back to Run.:</p> <ul style="list-style-type: none"> <li>• Check the wiring</li> <li>• Check the input signals</li> <li>• Check the power supply providing input signals</li> <li>• Consider adjusting the debounce times</li> <li>• Cycle input</li> </ul>
2.4 or 2.6	Simultaneity Fault	<p>On a dual-complementary input, one input of a complementary pair went into the Run state, but the other input of the same complementary pair did not follow the change within the time limit:</p> <ul style="list-style-type: none"> <li>• Check the wiring</li> <li>• Check the input signal timing</li> <li>• Cycle input</li> </ul>
2.7	Internal Fault	Internal failure— Contact BERNSTEIN AG (see <a href="#">Repairs and Warranty Service</a> on p. 191)
2.8 – 2.9	Input Fault	<p>Input stuck high:</p> <ul style="list-style-type: none"> <li>• Check for shorts to other inputs or other voltage sources</li> <li>• Check the input device compatibility</li> </ul>
2.10	Input Fault	<ul style="list-style-type: none"> <li>• Check for a short between inputs</li> </ul>
2.11 – 2.12	Input Fault	<ul style="list-style-type: none"> <li>• Check for a short to ground</li> </ul>
2.13	Input Fault	<p>Input stuck low</p> <ul style="list-style-type: none"> <li>• Check for a short to ground</li> </ul>
2.14	Input Fault	<p>Missing test pulses:</p> <ul style="list-style-type: none"> <li>• Check for a short to other inputs or other voltage sources</li> </ul>
2.15	Open Lead	<ul style="list-style-type: none"> <li>• Check for an open lead</li> </ul>
2.16 – 2.18	Input Fault	<p>Missing test pulses:</p> <ul style="list-style-type: none"> <li>• Check for a short to other inputs or other voltage sources</li> </ul>
2.19	Open Lead	<ul style="list-style-type: none"> <li>• Check for an open lead</li> </ul>
2.20	Input Fault	<p>Missing test pulses:</p> <ul style="list-style-type: none"> <li>• Check for a short to ground</li> </ul>
2.21	Open Lead	<ul style="list-style-type: none"> <li>• Check for an open lead</li> </ul>
2.22 – 2.23	Input Fault	<ul style="list-style-type: none"> <li>• Check for an unstable signal on the input</li> </ul>
2.24	Input Activated While Bypassed	A Two-Hand Control input was activated (turned On) while it was bypassed.
2.25	Input Fault	<p>After the associated Safety Output turned Off, the AVM input did not close before its AVM monitoring time expired:</p> <ul style="list-style-type: none"> <li>• The AVM may be disconnected. Check the wiring to the AVM</li> <li>• Either the AVM is disconnected, or its response to the Safety Output turning Off is too slow</li> <li>• Check the wiring to the AVM</li> <li>• Check the timing setting; increase the setting if necessary</li> <li>• Contact BERNSTEIN</li> </ul>
2.26	Input Fault	<p>The AVM input was open, but should have been closed, when the associated Safety Output was commanded On:</p> <ul style="list-style-type: none"> <li>• The AVM may be disconnected. Check the wiring to the AVM</li> </ul>
3.1	EDMxx Fault	<p>EDM contact opened prior to turning On the Safety Outputs:</p> <ul style="list-style-type: none"> <li>• Check for a stuck On contactor or relay</li> <li>• Check for an open wire</li> </ul>

Fault Code	Fault Code Description	Steps to resolve
3.2	EDMxx Fault	EDM contact(s) failed to close within 250 ms after the Safety Outputs turned Off: <ul style="list-style-type: none"> <li>• Check for a slow or stuck On contactor or relay</li> <li>• Check for an open wire</li> </ul>
3.3	EDMxx Fault	EDM contact(s) opened prior to turning On the Safety Outputs: <ul style="list-style-type: none"> <li>• Check for a stuck On contactor or relay</li> <li>• Check for an open wire</li> </ul>
3.4	EDMxx Fault	EDM contact pair mismatched for longer than 250 ms: <ul style="list-style-type: none"> <li>• Check for a slow or stuck On contactor or relay</li> <li>• Check for an open wire</li> </ul>
3.5	EDMxx Fault	<ul style="list-style-type: none"> <li>• Check for an unstable signal on the input</li> </ul>
3.6	EDMxx Fault	<ul style="list-style-type: none"> <li>• Check for a short to ground</li> </ul>
3.7	EDMxx Fault	<ul style="list-style-type: none"> <li>• Check for a short between inputs</li> </ul>
3.8	AVMxx Fault	After this Safety Output turned Off, an AVM input associated with this output did not close before its AVM monitoring time expired: <ul style="list-style-type: none"> <li>• The AVM may be disconnected or its response to the Safety Output turning Off may be too slow</li> <li>• Check the AVM input and then perform a System Reset to clear the fault</li> </ul>
3.9	Input Fault	The AVM input was open, but should have been closed, when the associated Safety Output was commanded On: <ul style="list-style-type: none"> <li>• The AVM may be disconnected. Check the wiring to the AVM</li> </ul>
3.10	Internal Fault	Internal failure— Contact BERNSTEIN AG (see <a href="#">Repairs and Warranty Service</a> on p. 191)
4.1	Supply Voltage Low	The supply voltage dropped below the rated voltage for longer than 6 ms: <ul style="list-style-type: none"> <li>• Check the power supply voltage and current rating</li> <li>• Check for an overload on the outputs that might cause the power supply to limit the current</li> </ul>
4.2	Internal Fault	A configuration parameter has become corrupt. To fix the configuration: <ul style="list-style-type: none"> <li>• Replace the configuration by using a backup copy of the configuration</li> <li>• Recreate the configuration using the Software and write it to the Safety Controller</li> </ul>
4.3 – 4.12	Internal Fault	Internal failure— Contact BERNSTEIN AG (see <a href="#">Repairs and Warranty Service</a> on p. 191)
4.13	Configuration Timeout	The Safety Controller was left in Configuration mode for more than one hour without receiving any commands from the Software.
4.14	Configuration Unconfirmed	The configuration was not confirmed after being edited: <ul style="list-style-type: none"> <li>• Confirm configuration using the Software</li> </ul>
4.15 – 4.19	Internal Fault	Internal failure— Contact BERNSTEIN AG (see <a href="#">Repairs and Warranty Service</a> on p. 191)
4.20	Unassigned Terminal in Use	This terminal is not mapped to any device in the present configuration and should not be active: <ul style="list-style-type: none"> <li>• Check the wiring</li> </ul>
4.21 – 4.34	Internal Fault	Internal failure— Contact BERNSTEIN AG (see <a href="#">Repairs and Warranty Service</a> on p. 191)
4.35	Overtemperature	An internal overtemperature condition has occurred. Verify that the ambient and output loading conditions meet the specifications of the Safety Controller.
4.36 – 4.47	Internal Fault	Internal failure— Contact BERNSTEIN AG (see <a href="#">Repairs and Warranty Service</a> on p. 191)
4.48	Unused output	A voltage was detected on an unconfirmed terminal.
4.49 – 4.59	Internal Fault	Internal failure— Contact BERNSTEIN AG (see <a href="#">Repairs and Warranty Service</a> on p. 191)
4.60	Output Fault	An output terminal detected a short. Check output fault for details.
5.1 – 5.3	Internal Fault	Internal failure— Contact BERNSTEIN AG (see <a href="#">Repairs and Warranty Service</a> on p. 191)
6.xx	Internal Fault	Invalid configuration data. Possible internal failure: <ul style="list-style-type: none"> <li>• Try writing a new configuration to the Safety Controller</li> </ul>
10.xx	Internal Fault	Internal failure— Contact BERNSTEIN AG (see <a href="#">Repairs and Warranty Service</a> on p. 191)

## 13 Components and Accessories

### 13.1 Replacement Parts and Accessories

Model	Description	Product ID
SCR P-FPS	External memory drive for the SCR P	3919100252
SCR P-PA	Programming tool for SCR P-FPS	3919100250
USB-Kabel A/ Micro-B	USB cable	3919100251

## 14 Product Support and Maintenance

### 14.1 Cleaning

1. **Disconnect power to the Safety Controller.**
2. Wipe down the polycarbonate enclosure and the display (models with display) with a soft cloth that has been dampened with a mild detergent and warm water solution.

### 14.2 Repairs and Warranty Service

Contact BERNSTEIN for troubleshooting of this device. **Do not attempt any repairs to this BERNSTEIN device; it contains no field-replaceable parts or components.** If the device, device part, or device component is determined to be defective by a BERNSTEIN Applications Engineer, they will advise you of BERNSTEIN's RMA (Return Merchandise Authorization) procedure.



**Important:** If instructed to return the device, pack it with care. Damage that occurs in return shipping is not covered by warranty.

To assist BERNSTEIN with troubleshooting a problem, while the PC is connected to the Safety Controller, go to Help in the software and click Support Information. Click **Save Controller Diagnostics** (located at **Help > Support Information**) to generate a file that contains status information. This information may be helpful to the support team at BERNSTEIN. Send the file to BERNSTEIN according to the instructions provided on screen.

### 14.3 Contact Us

BERNSTEIN AG headquarters is located at:

Hans-Bernstein-Str. 1, 32457 Porta Westfalica, Germany

Website: [www.bernstein.eu](http://www.bernstein.eu)

Phone: + 49 571/793-0

For worldwide locations and local representatives, visit [www.bernstein.eu](http://www.bernstein.eu)

### 14.4 BERNSTEIN Software Copyright Notice

This software is protected by copyright, trade secret, and other intellectual property laws. You are only granted the right to use the software and only for the purposes described by BERNSTEIN. BERNSTEIN reserves all other rights in this software. For so long as you have obtained an authorized copy of this software directly from BERNSTEIN, BERNSTEIN grants you a limited, nonexclusive, nontransferable right and license to use this software.

You agree not to use, nor permit any third party to use, this software or content in a manner that violates any applicable law, regulation or terms of use under this Agreement. You agree that you will not reproduce, modify, copy, deconstruct, sell, trade or resell this software or make it available to any file-sharing or application hosting service.

**Disclaimer of Warranties.** Your use of this software is entirely at your own risk, except as described in this agreement. This software is provided "AS-IS." To the maximum extent permitted by applicable law, BERNSTEIN, its affiliates, and its channel partners disclaim all warranties, expressed or implied, including any warranty that the software is fit for a particular purpose, title, merchantability, data loss, non-interference with or non-infringement of any intellectual property rights, or the accuracy, reliability, quality or content in or linked to the services. BERNSTEIN and its affiliates and channel partners do not warrant that the services are secure, free from bugs, viruses, interruption, errors, theft or destruction. If the exclusions for implied warranties do not apply to you, any implied warranties are limited to 60 days from the date of first use of this software.

**Limitation of Liability and Indemnity.** BERNSTEIN, its affiliates and channel partners are not liable for indirect, special, incidental, punitive or consequential damages, damages relating to corruption, security, loss or theft of data, viruses, spyware, loss of business, revenue, profits, or investment, or use of software or hardware that does not meet BERNSTEIN minimum systems requirements. The above limitations apply even if BERNSTEIN and its affiliates and channel partners have been advised of the possibility of such damages. This Agreement sets forth the entire liability of BERNSTEIN, its affiliates and your exclusive remedy with respect to the software use. You agree to indemnify and hold BERNSTEIN and its affiliates and channel partners harmless from any and all claims, liability and expenses, including reasonable attorney's fees and costs, arising out of your use of the Services or breach of this Agreement (collectively referred to as "Claims"). BERNSTEIN reserves the right at its sole discretion and at its own expense, to assume the exclusive defense and control of any Claims. You agree to reasonably cooperate as requested by BERNSTEIN in defense of any Claims.

# 15 Standards and Regulations

*The list of standards below is included as a convenience for users of this BERNSTEIN device. Inclusion of the standards below does not imply that the device complies specifically with any standard, other than those specified in the Specifications section of this manual.*

## 15.1 Applicable European and International Standards

---

EN ISO 12100 Safety of Machinery – General Principles for Design — Risk Assessment and Risk Reduction  
ISO 13857 Safety Distances . . . Upper and Lower Limbs  
ISO 13850 (EN 418) Emergency Stop Devices, Functional Aspects – Principles for Design  
ISO 13851 Two-Hand Control Devices – Principles for Design and Selection  
IEC 62061 Functional Safety of Safety-Related Electrical, Electronic and Programmable Control Systems  
EN ISO 13849-1 Safety-Related Parts of Control Systems  
EN 13855 (EN 999) The Positioning of Protective Equipment in Respect to Approach Speeds of Parts of the Human Body  
ISO 14119 (EN 1088) Interlocking Devices Associated with Guards – Principles for Design and Selection  
EN 60204-1 Electrical Equipment of Machines Part 1: General Requirements  
IEC 61496 Electro-sensitive Protection Equipment  
IEC 60529 Degrees of Protection Provided by Enclosures  
IEC 60947-1 Low Voltage Switchgear – General Rules  
IEC 60947-5-1 Low Voltage Switchgear – Electromechanical Control Circuit Devices  
IEC 60947-5-5 Low Voltage Switchgear – Electrical Emergency Stop Device with Mechanical Latching Function  
IEC 61508 Functional Safety of Electrical/Electronic/Programmable Electronic Safety-Related Systems  
IEC 62046 Safety of Machinery – Applications of Protective Equipment to Detect the Presence of Persons



## 15.2 Applicable U.S. Standards

---

ANSI B11.0 Safety of Machinery, General Requirements, and Risk Assessment	ANSI B11.15 Pipe, Tube, and Shape Bending Machines
ANSI B11.1 Mechanical Power Presses	ANSI B11.16 Metal Powder Compacting Presses
ANSI B11.2 Hydraulic Power Presses	ANSI B11.17 Horizontal Extrusion Presses
ANSI B11.3 Power Press Brakes	ANSI B11.18 Machinery and Machine Systems for the Processing of Coiled Strip, Sheet, and Plate
ANSI B11.4 Shears	ANSI B11.19 Performance Criteria for Safeguarding
ANSI B11.5 Iron	ANSI B11.20 Manufacturing Systems
Workers ANSI B11.6	ANSI B11.21 Machine Tools Using Lasers
Lathes	ANSI B11.22 Numerically Controlled Turning Machines
ANSI B11.7 Cold Headers and Cold Formers	ANSI B11.23 Machining Centers
ANSI B11.8 Drilling, Milling, and Boring	ANSI B11.24 Transfer Machines
ANSI B11.9 Grinding Machines	ANSI/RIA R15.06 Safety Requirements for Industrial Robots and Robot Systems
ANSI B11.10 Metal Sawing Machines	ANSI NFPA 79 Electrical Standard for Industrial Machinery
ANSI B11.11 Gear Cutting Machines	ANSI/PMMI B155.1 Package Machinery and Packaging-Related Converting Machinery — Safety Requirements
ANSI B11.12 Roll Forming and Roll Bending Machines	
ANSI B11.13 Single- and Multiple-Spindle Automatic Bar and Chucking Machines	
ANSI B11.14 Coil Slitting Machines	

## 15.3 Applicable OSHA Regulations

---

OSHA Documents listed are part of: Code of Federal Regulations Title 29, Parts 1900 to 1910

OSHA 29 CFR 1910.212 General Requirements for (Guarding of) All Machines

OSHA 29 CFR 1910.147 The Control of Hazardous Energy (lockout/tagout)

OSHA 29 CFR 1910.217 (Guarding of) Mechanical Power Presses

# 16 Glossary

## A

### Automatic Reset

The safety input device control operation setting where the assigned safety output will automatically turn on when all of its associated input devices are in the Run state.

## C

### Change of State (COS)

The change of an input signal when it switches from Run-to-Stop or Stop-to-Run state.

### Closed-Open Debounce Time

Time to bridge a jittery input signal or bouncing of input contacts to prevent nuisance tripping of the Controller. Adjustable from 6 ms to 100 ms. The default value is 6 ms (50 ms for mute sensors).

### Complementary Contacts

Two sets of contacts which are always in opposite states.

### Concurrent (also Concurrency)

The setting in which both channels must be off at the same time before turning back on. If this is not satisfied, the input will be in a fault condition.

## D

### Designated Person

A person or persons identified and designated in writing, by the employer, as being appropriately trained and qualified to perform a specified checkout procedure.

### Diverse-Redundancy

The practice of using components, circuitry or operation of different designs, architectures or functions to achieve redundancy and to reduce the possibility of common mode failures.

### Dual-Channel

Having redundant signal lines for each safety input or safety output.

### DCD

The In-Series Diagnostics (DCD) communication protocol provides performance and status information from each device in a chain to the PLC and/or HMI. Notification is sent for the opening or closing of a door, mismatched or misaligned sensors and actuators, and a range of additional system health attributes.

## F

### Fault

A state of a device characterized by the inability to perform a required function, excluding the inability during preventive maintenance or other planned actions, or due to lack of external resources. A fault is often the result of a failure of the device itself, but may exist without prior failure.

## H

### Hard (Fixed) Guard

Screens, bars, or other mechanical barriers affixed to the frame of the machine intended to prevent entry by personnel into the hazardous area(s) of a machine, while allowing the point of operation to be viewed. The maximum size of the openings is determined by the applicable standard, such as Table O-10 of OSHA 29CFR1910.217, also called a "fixed barrier guard."

## M

### Machine Response Time

The time between the activation of a machine stopping device and the instant when the dangerous parts of the machine reach a safe state by being brought to rest.

### Manual reset

The safety input device control operation setting where the assigned safety output will turn On only after a manual reset is performed and if the other associated input devices are in their Run state.

O

**Off Signal**

The safety output signal that results when at least one of its associated input device signals changes to the Stop state. In this manual, the safety output is said to be Off or in the Off state when the signal is 0 V dc nominally.

**On Signal**

The safety output signal that results when all of its associated input device signals change to the Run state. In this manual, the safety output is said to be On or in the On state when the signal is 24 V dc nominally.

**Open-Closed Debounce Time**

Time to bridge a jittery input signal or bouncing of input contacts to prevent unwanted start of the machine. Adjustable from 10 ms to 500 ms. The default value is 50 ms.

P

**Pass-Through Hazard**

A pass-through hazard is associated with applications where personnel may pass through a safeguard (which issues a stop command to remove the hazard), and then continues into the guarded area, such as in perimeter guarding. Subsequently, their presence is no longer detected, and the related danger becomes the unexpected start or restart of the machine while personnel are within the guarded area.

**PELV**

Protected extra-low voltage power supply, for circuits with earth ground. Per IEC 61140: "A PELV system is an electrical system in which the voltage cannot exceed ELV (25 V ac rms or 60 V ripple free dc) under normal conditions, and under single-fault conditions, except earth faults in other circuits."

Q

**Qualified Person**

A person who, by possession of a recognized degree or certificate of professional training, or who, by extensive knowledge, training and experience, has successfully demonstrated the ability to solve problems relating to the subject matter and work.

R

**Run Signal**

The input signal monitored by the Controller that, when detected, causes one or more safety outputs to turn On, if their other associated input signals are also in the Run state.

S

**SELV**

Separated or safety extra-low voltage power supply, for circuits without earth ground. Per IEC 61140: "A SELV system is an electrical system in which the voltage cannot exceed ELV (25 V ac rms or 60 V ripple free dc) under normal conditions, and under single-fault conditions, including earth faults in other circuits."

**Simultaneous (also Simultaneity)**

The setting in which both channels must be off at the same time AND, when they turn back on, they must turn on within 3 seconds of each other. If both conditions are not satisfied, the input will be in a fault condition.

**Single-Channel**

Having only one signal line for a safety input or safety output.

**Start Up Test**

For certain safety devices, like safety light screens or safety gates, it can be an advantage to test the device on power up at least one time for proper function.

**Stop Signal**

The input signal monitored by the Controller that, when detected, causes one or more safety outputs to turn Off. In this manual, either the input device or device signal is said to be in the Stop state.

**System Reset**

A configurable reset of one or more safety outputs to turn On after Controller power-up, when set for manual power-up, or lockout (fault detection) situations.