



BRACKET GM60



SUSPENSION SYSTEM



ARTICULATED JOINT



ARTICULATED ARMS

- EN 1.4307 (TYPE 304L) s/s tube execution, \varnothing . 60.3 thick.3, satin-finish: on demand polish or micro-peening finish available.
- Available bent to "L", "J" or "S" shape, or "I" shape.
- Some widths are preset and available from the stock (see table), other sizes are available on demand.
- Fixed or articulated joints can be set on the ends, to meet different needs.
- The arm is usually delivered with joints on. Since the GKSA and GCSA joint can be installed without welds, they can be fitted directly by customer after adjusting the arm to its needs.

NOTE: if the arm is expected to support any item other than our boxes series BC-BK, the stiffness of the wall to be supported needs checking.

L= MIN 400 E H= MIN 240

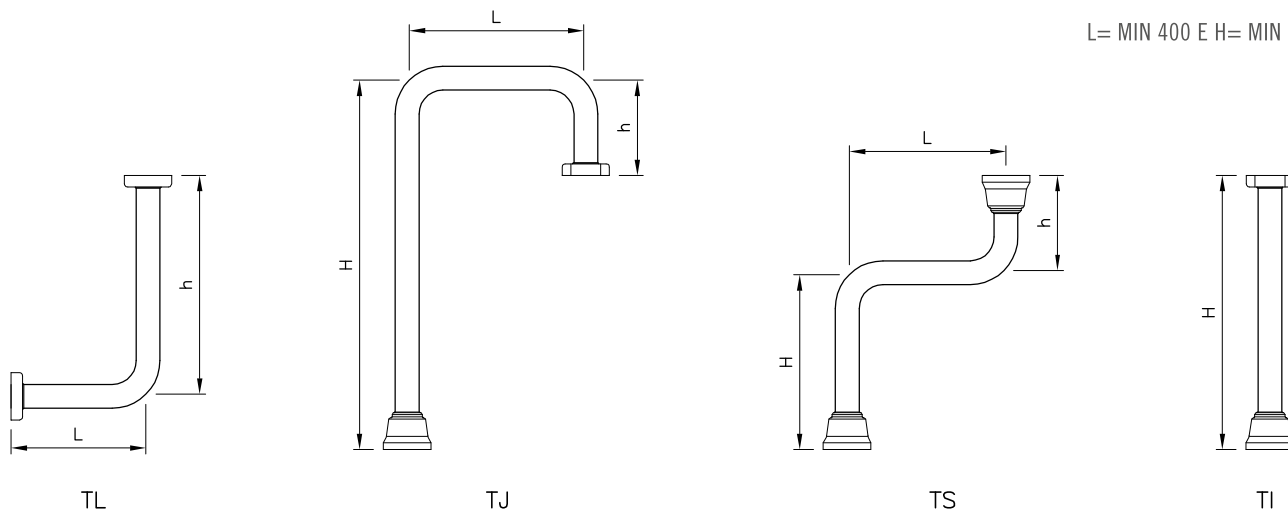

Standard sizes from the stock: L= 400 – 475 – 550 – 625 – 700 – 775
Other sizes available on demand.

ORDERING CODE IDENTIFICATION TABLE

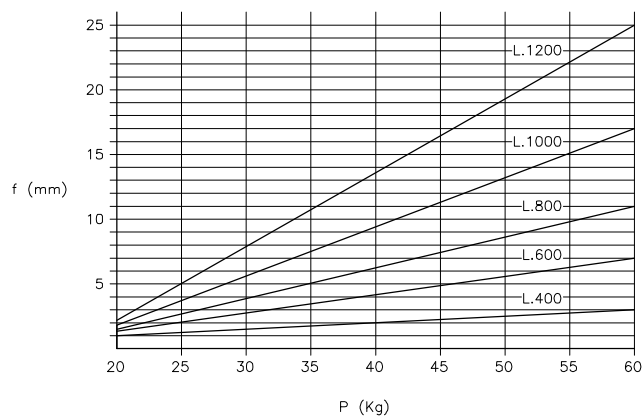
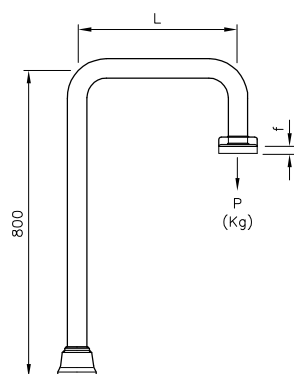
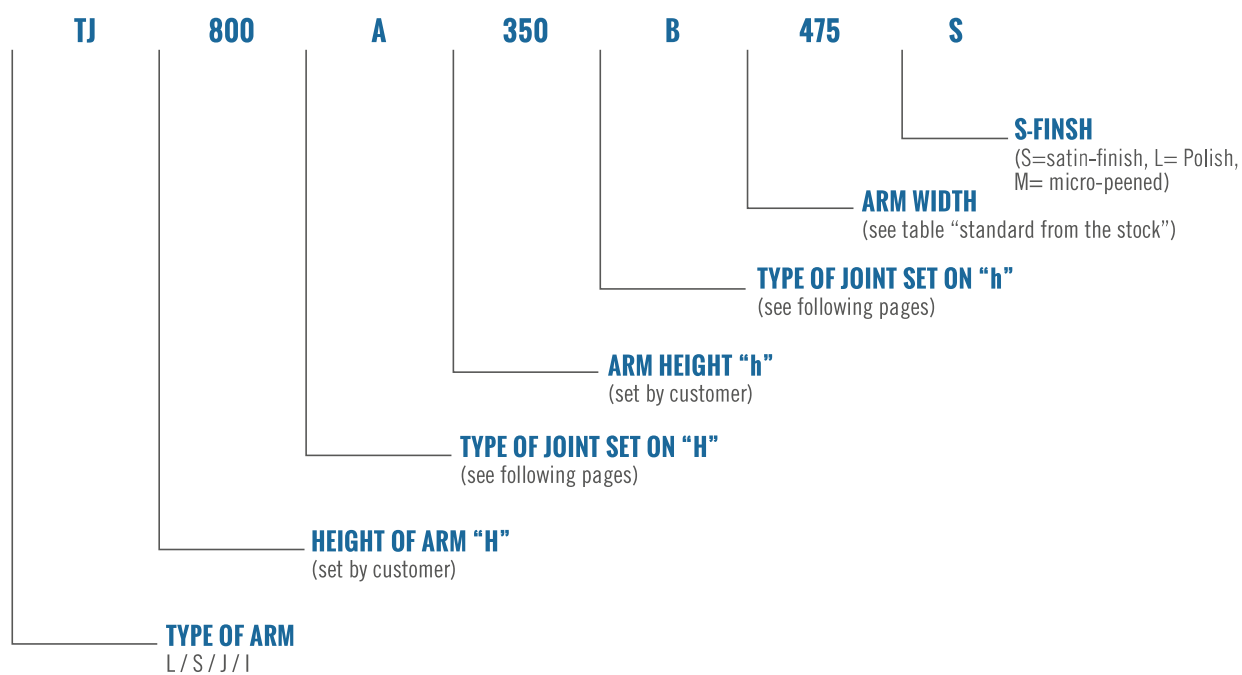

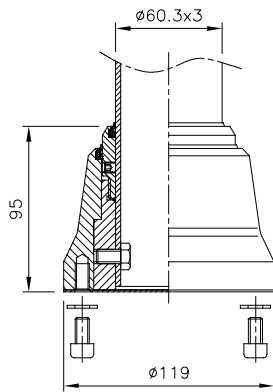

ARTICULATED JOINT GCSA ('A')

EN 1.4307 (TYPE 304L) s/s execution, complete with seal to guarantee tightness. The special form and the manufacturing criteria guarantee high stiffness and make it suitable for use either at the bottom of the arm or for coupling with big-sized control boxes or bottom-supported ones. The frame on which the joint is to be fastened must be very stiff. Since the joint can be installed without welds, it can be assembled directly by customer after adjusting the arm to its needs. The rotation angle can be limited to 85°, 175°, 265° or 355°.

- **GCSA** – universal articulated joint, IP66 and IP69K

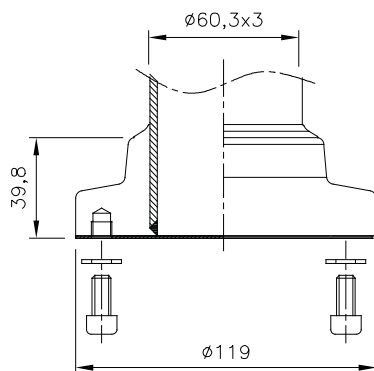

ARTICULATED JOINT GKSA ('B')

EN 1.4307 (TYPE 304L) s/s execution, complete with gaskets to Guarantee tightness, its simple and unitized shape makes it particularly for coupling with hanging control boxes. The joint does not require any weld, hence it can be installed directly by customer after adjusting the arm to its needs. Comes complete with a retainer that limits its rotation to 85°-175°- 265°-355°. It's possible to fix the joint.

- **GKSA** – articulated joint for coupling with control boxes BK, IP66 and IP69K

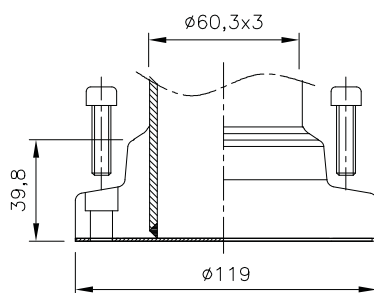

ARTICULATED JOINT GKSEA ('C')

EN 1.4307 (TYPE 304L) s/s execution, complete with gaskets to Guarantee tightness, its simple and unitized shape makes it particularly for coupling with hanging control boxes. The joint does not require any weld, hence it can be installed directly by customer after adjusting the arm to its needs. Comes complete with a retainer that limits its rotation to 85°-175°- 265°-355°. It's possible to fix the joint. It's possible to fix the joint. Can be fixed from the outside of the frame on which it is set.

- **GKSEA** – articulated joint for coupling with control boxes BK, IP66 and IP69K

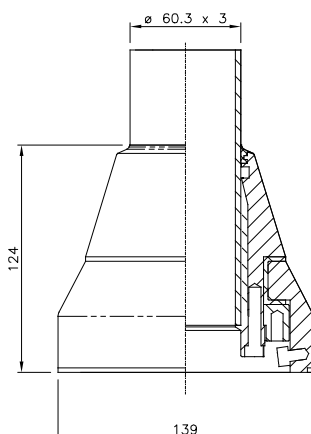

ARTICULATED JOINT GRH ('D')

EN 1.4307 (TYPE 304L) s/s execution, complete with blue seal to guarantee tightness. The special form and the manufacturing criteria guarantee high stiffness and make it suitable for use either at the bottom of the arm or for coupling with big-sized control boxes or bottom-supported ones. The frame on which the joint is to be fastened must be very stiff. Since the joint can be installed without welds, it can be assembled directly by customer after adjusting the arm to its needs. Internal clutch to guarantee easily rotation.

- **GRH** – universal articulated joint

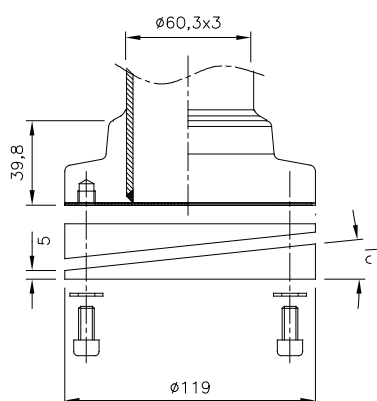

ARTICULATED JOINT GKSHA ('E')

Universal articulated joint EN 1.4307 (TYPE 304L) s/s execution, complete with seal to guarantee tightness. The special form and the manufacturing criteria guarantee high stiffness and make it suitable for use either at the bottom of the arm or for coupling with big-sized control boxes or bottom-supported ones. The frame on which the joint is to be fastened must be very stiff. Since the joint can be installed without welds, it can be assembled directly by customer after adjusting the arm to its needs. The rotation angle can be limited to 85°, 175°, 265° or 355°. It's possible to fix the joint. With sloping flange 10°

- GKSHA – universal articulated joint for BKH, IP66 and IP69K

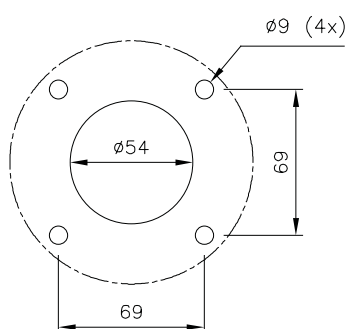

DRILLING TEMPLATE

- TEMPLATE GCSA

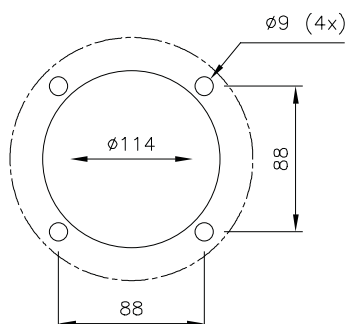

DRILLING TEMPLATE

- TEMPLATE GRH

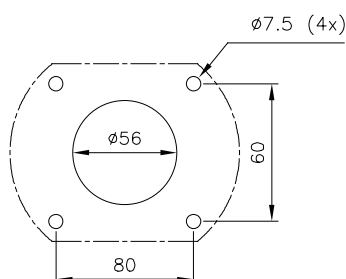

DRILLING TEMPLATE

- TEMPLATE GKSA



BRACKET GM60

All EN 1.4307 (TYPE 304L) s/s execution, polished, sturdy and mirror or satin. To be bolted, after assembling the articulated joint with the arm, from the inside of a stiff frame. This kind of assembling avoids the presence of exposed screws and assures maximum hygienic conditions; when this is not possible, combine it with the FFM flange for outside fixing.

- **GM60** – rounded bracket mirror
- **GM60S** – rounded bracket satin

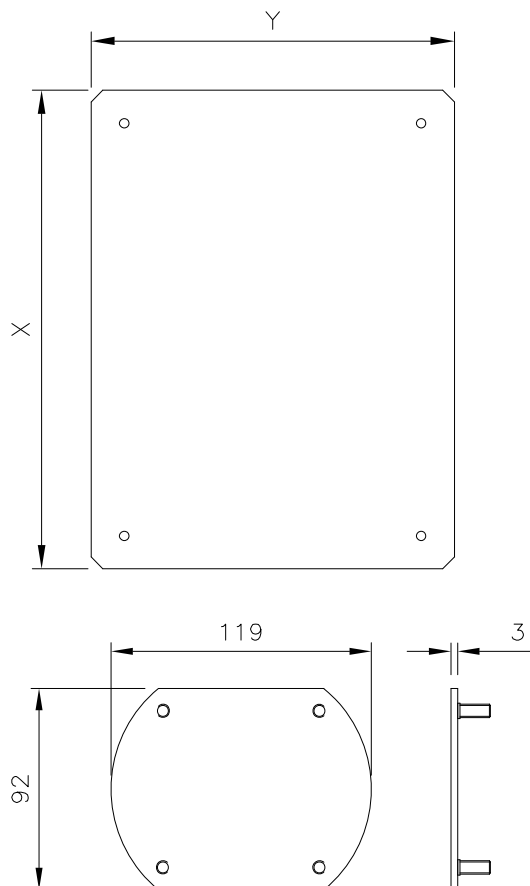
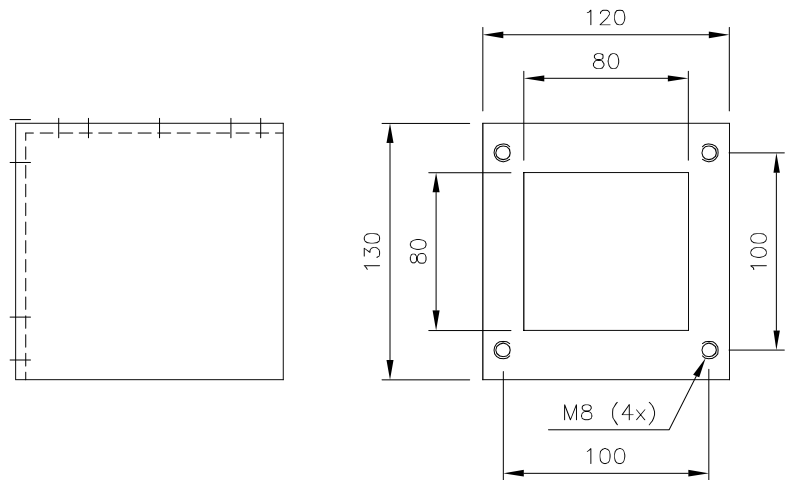

INNER PLATES

They come in sendzimir execution and, on demand, in s/s. The plate is secured by the stud bolts set inside the enclosure.

	INNER PLATES BOX	
	X	H
PIBC32	333	152
PIBC43	433	227
PIBC53	505	277
PIBC64	580	327
PIBK33	306	252
PIBK43	306	406
PIBK44	406	406
PIBK54	476	406
PIBK55	456	456
PIBK65	556	456

PLUG

EN 1.4307 (TYPE 304L) s/s execution, fine satin-finish. Closing plug hole, for box item BK and BC.